

In the name of Allah



Islamic University of Gaza
Deanery of Post Graduate Studies
Faculty of Engineering
Electrical and Computer Engineering Department

COVERAGE & CAPACITY IMPROVEMENTS IN THE 3.5G CELLULAR NETWORK BY PARAMETER AND NETWORK MODIFICATION.

Submitted by: Eng. Ahmed S. Shbair.

**Supervised by: Dr. Ammar Abu Hudrouss
Dr. Anwar Mousa**

**A Thesis Submitted in Partial Fulfillment of the Requirements for the Degree of Master in
Electrical/control Systems Engineering.**

2010 AC – 1431H



نتيجة الحكم على أطروحة ماجستير

بناءً على موافقة عمادة الدراسات العليا بالجامعة الإسلامية بغزة على تشكيل لجنة الحكم على أطروحة الباحث/ أحمد شكري شاكر شبيب لنيل درجة الماجستير في كلية الهندسة /قسم الهندسة الكهربائية/أنظمة التحكم وموضوعها:

Coverage and Capacity Improvements in the 3.5G Cellular Network by Parameter and Network Modifications

وبعد المناقشة العلنية التي تمت اليوم الاثنين 07 شعبان 1431هـ، الموافق 2010/07/19م الساعة العاشرة صباحاً، اجتمعت لجنة الحكم على الأطروحة والمكونة من:

..... Ammay	مشرفاً ورئيساً	د. عمّار محمد أبو هديوس
..... [Signature]	مشرفاً	د. أنور محمد موسى
..... [Signature]	مناقشاً داخلياً	د. فادي إبراهيم النحال
..... [Signature]	مناقشاً داخلياً	د. حاتم علي العايدي

وبعد المداولة أوصت اللجنة بمنح الباحث درجة الماجستير في كلية الهندسة / قسم الهندسة الكهربائية/أنظمة التحكم.

واللجنة إذ تمنحه هذه الدرجة فإنها توصيه بتقوى الله ولزوم طاعته وأن يسخر علمه في خدمة دينه ووطنه.

والله والتوفيق،،،

عميد الدراسات العليا

.....
[Signature]

د. زياد إبراهيم مقداد

Abstract

3.5G Cellular networks have a great advantage over the 3G cellular networks. This advantage comes from splitting the two-way symmetric connections into two asymmetric connections. This splitting allows data communications with all their applications such as web browsing and files transferring.

But these 3.5G cellular networks, as their predecessor, suffer a major problem due to the adopted multiple access scheme. Theoretically, the scheme accepts an infinite number of users, while practically, as the number of users increases, the quality of service degrades and the covered area shrinks.

Eliminating this obstacle increases the performance of the 3.5G cellular network. This elimination is our main objective, which is increasing the number of users while maintaining the covered area without shrinking.

To meet our main objective and justify it practically, it is splitted into two separate but complementary sub-objectives.

The first sub-object is modifying the parameters of the 3.5G cellular network, such as redialing mode and Service Activity Factor, and modifying the 3.5G cellular network itself by cell splitting and sectoring to improve the coverage and capacity.

An original cellular network is established and its metrics; number of connected users, number of blocked users, number of disconnected users and number of handovers done by users are recorded. Then a modification is applied and the metrics are recorded again. The improvement is measured by comparing the metrics after modification to the metrics before modification.

The second sub-objective is developing (designing, programming, coding and running) a simulation platform to produce numeric results which are analyzed to justify the predictions without using any existing simulation package or software.

Simulation results prove the enhancement in coverage and capacity of the 3.5G cellular networks. Cell splitting and sectoring improve the coverage and capacity of the network proportional to the splitting and sectoring level, with a low transmitted power advantage for splitting. Also varying the Service Activity Factor and the redial mode improve the coverage and the capacity of the network. But the amount of improvement depends on the choice of variance.

Coding and programming of the simulation platform is done with C++. Visualizing the results is performed using MATLAB to facilitate reading and comparing tons of results' files.

ملخص الأطروحة

لشبكات الجيل 3.5 الخليوية ميزة عظيمة عن شبكات الجيل 3. هذه الميزة تأتي من تقسيم الاتصال الثنائي الاتجاه المتماثل إلى اتصاليين أحاديي الاتجاه غير متماثلين. هذا التقسيم سمح باتصالات المعلومات بما يرتبط بها من تطبيقات كتصفح الإنترنت و نقل الملفات.

لكن شبكات الجيل 3.5 الخليوية كسابقاتها تعاني من مشكلة كبيرة ناشئة عن طريقة تعدد الوصول المعتمدة. نظرياً تسمح طريقة تعدد الوصول المعتمدة بعدد لا نهائي من المستخدمين، ولكن عملياً، كلما زاد عدد المستخدمين قلت جودة الخدمة وانكمشت المساحة المغطاة.

إزالة هذه المعضلة من شبكات الجيل 3.5 الخليوية يؤدي إلى تحسين كفاءة الشبكة. وإزالة هذه المعضلة هو الهدف الرئيسي من هذه الرسالة و هو زيادة عدد المستخدمين مع المحافظة على المساحة المغطاة دون انكماش.

لإحراز هذا الهدف الرئيسي والتحقق منه عملياً، فقد تم تجزئته إلى هدفين منفصلين متكاملين:

الهدف الأول تعديل إعدادات شبكة الجيل 3.5 الخليوية مثل: نوعية إعادة الاتصال، وعامل نشاط خدمة المستخدمين، وكذلك تعديل الشبكة ذاتها بتقسيم الخلية إلى خلايا جديدة أصغر، وتقسيم الخلية إلى قطاعات لتحسين التغطية والسعة.

بدايةً، يتم تأسيس الشبكة الخليوية الأصلية وتسجيل القيم الأولية للعوامل أو المقاييس التي تحدد كفاءة الشبكة: عدد المتصلين بنجاح، عدد المستخدمين المصدودين (لم يتم قبول اتصالاتهم)، عدد المستخدمين المفصولين (اتصلوا فترة ثم انقطع اتصالاتهم) وعدد المستخدمين الذين تم تحويلهم من وإلى الخلايا. ثم يتم تطبيق التعديل المقترح، ومن ثم يتم تسجيل قيم العوامل أو المقاييس سابقة الذكر. وبمقارنة هذه القيم قبل وبعد التعديل يتم قياس التحسن في كفاءة الشبكة.

الهدف الثاني هو وضع (تصميم وبرمجة وكتابة وتشغيل) برنامج محاكاة لإعطاء النتائج الرقمية، والتي يتم تحليلها للتحقق من بلوغ الهدف الأول بدون استعمال أي حزم برمجية أو برامج محاكاة جاهزة.

نتائج المحاكاة أثبتت التحسن في تغطية وسعة شبكات الجيل 3.5 الخليوية. تقسيم الخلايا إلى خلايا أصغر أو قطاعات حسن التغطية والسعة. وهذا التحسن يتناسب طردياً مع درجة التقسيم مع أفضلية التقسيم إلى خلايا أصغر لما يتم فيها من بث مستويات طاقة منخفضة. كما أثبت تغيير معامل نشاط خدمة المستخدمين ونوعية إعادة الاتصال التحسن في التغطية والسعة للشبكة ولكن مقدار التحسن يعتمد على اختيار قيمة التغيير.

برمجة وكتابة برنامج المحاكاة تمت باستخدام لغة السي ++. أما عرض هذه النتائج بأشكال بيانية فقد تم باستخدام برنامج الماتلاب لتسهيل قراءة ومقارنة أطنان الملفات الناتجة.

بِسْمِ اللَّهِ الرَّحْمَنِ الرَّحِيمِ



﴿ قُلْ إِنَّ صَلَاتِي وَنُسُكِي وَمَحْيَايَ وَمَمَاتِي لِلَّهِ رَبِّ الْعَالَمِينَ ﴾



﴿ لَا شَرِيكَ لَهُ وَبِذَلِكَ أُمِرْتُ وَأَنَا أَوَّلُ الْمُسْلِمِينَ ﴾

صدق الله العظيم

سورة الأنعام

Acknowledgement

A lot of dramatic events passed during this degree, and I could not pass them if I were alone. I think this is the best opportunity to thank who helped me completing this.

First, I want to mark my deepest thanks for Allah, who guided me and made it easy for me.

Then, I am grateful to my advisor Dr. Anwar Mousa, who opened the way to telecommunication through his two courses and during his supervisory. Also I am grateful to my supervisor Dr. Ammar Abu Hudrouss as well.

I want to thank also my parents, my parents-in-law!, my wife Ayat, my brother Dr. Shaker, my sisters Dr. Rawya, Intisar, Ibtehal and Hanan and my kind sister-in-law Fatma for their support.

I want to thank my kids Laila, Shukri and Ihsan for the time I spent studying, which I cut from setting and playing with them.

شكر و تقدير

مرت أحداث جسام خلال الماجستير، ولو كنت وحدي لما استطعت إكمالها. و هذه أفضل فرصة لأشكر من أسهم وساعدني في إنجازها.

أولاً: الحمد والشكر لله عز وجل الذي بهدايته وتوفيقه سهّل إتمام العمل.

ثم أدين بالعرفان للمشرفين على هذا العمل: الدكتور أنور موسى، الذي فتح مجال الاتصالات الخليوية أمامي من خلال المقررين اللذين أخذتهما معه و من خلال إشرافه. وكذلك الدكتور عمار أبو هديوس على إشرافه.

كما أنتهز هذه الفرصة لأشكر والدي ووالدتي، وحماتي وحماتي! وزوجتي، وأخي الدكتور شاكر و أخواتي الدكتورة راوية، انتصار، الأستاذة ابتهاج، الأستاذة حنان و أخت زوجتي الرقيقة فاطمة على دعمهم المتواصل.

كما أحب أن أشكر أطفالي ليلى و شكري و إحسان على الوقت الذي استقطعته للدراسة من الوقت المخصص لمجالستهم و اللعب معهم.

Table of Contents

1	Introduction	1
1.1	History	2
1.2	Data Speed	2
1.3	Fields of the Research	3
1.3.1	Splitting the band among File Transfer Protocol (FTP) and Web browsing	3
1.3.2	System Capacity	3
1.3.3	System Coverage	3
1.3.4	User Satisfaction	4
1.4	Related Researches	4
1.5	Objectives	6
1.6	Thesis Contributions	7
1.7	Thesis Organization	8
2	Backbone Theory	9
2.1	Third Generation Cellular Network (3G)	9
2.1.1	User Equipment (UE)	9
2.1.2	Node B	10
2.2	High-Speed Downlink Packet Access (HSDPA)	10
2.2.1	Need for HSDPA	10
2.2.2	Deploying HSDPA	10
2.3	Code Division Multiple Access (CDMA)	10
2.4	Rake Receiver	11
2.5	Radio Signals Propagation	12
2.5.1	Free Space Propagation	12
2.5.2	Okumura Model	12
2.6	Cell splitting	14
2.7	Cell Sectoring	16
2.8	Performance metrics	16
2.8.1	Percentage of Unsatisfied Users	16
2.8.2	Handover Rate	17
2.8.2.1	Soft Handover (SHO)	18
2.8.2.2	Softer Handover	18
2.8.2.3	Hard Handover	18
2.8.2.4	Intersystem Handovers	19
2.9	Doppler Shift	19
2.10	Radiation Exposure	19
2.11	Programming Language	20
3	Implementation	21
3.1	Network Management System level simulation	21
3.2	Dynamic System Simulation	21
3.3	Simulation session	22
3.3.1	Deployment	22
3.3.2	Propagation model	24
3.3.3	Random Sample of Users	24
3.3.4	Mobility	24
3.3.5	Doppler Effect	25
3.3.6	Services	26
3.3.7	Simulation Phases	26
3.3.7.1	Initialize phase	27
3.3.7.2	Simulate phase	28
3.3.8	Checking Results	28
3.3.9	Filing	31
3.4	Cell Splitting	31
3.5	Sectoring	32
3.6	Radiation Exposure Calculations	33
3.7	Algorithm	34
3.8	Software	36
3.9	Assumptions and Limitations	37

4	Results	39
4.1	Varying the Redial mode for a system with web browsing Service Activity Factor 60% and FTP SAF 40%	39
4.1.1	Results	39
4.1.2	Notes about Results	39
4.2	Varying Web browsing Service Activity Factor to 50% and FTP SAF to 50%	40
4.2.1	Tabular Results	40
4.2.2	Varying SAF Comparisons	41
4.2.3	Results Analysis	41
4.3	Cell Splitting	42
4.3.1	Splitting Tabular Results	42
4.3.2	Splitting Results Analysis	42
4.4	Sectoring	43
4.4.1	Results	43
4.4.2	Comparing between cell splitting and sectoring	43
4.4.3	Results Analysis	44
5	Conclusions and Future Work	45
	References	47
	Appendix A	49
	Environmental Instructions	
	Appendix B	52
	Simulation Parameters	
	Appendix C	53
	Simulation Results	

List of Tables

Table 3.1	Node Bs and their adjacent	23
Table 3.2	Speed distributions	25
Table 4.1	Results of varying the redial modes with web SAF 60% and FTP SAF 40%	39
Table 4.2	Results of varying the redial modes with web SAF 50% and FTP SAF 50%	40
Table 4.3	Comparing results of varying web SAF from 50% to 60% and FTP SAF from 50% to 40%.	41
Table 4.4	Results of cell splitting	42
Table 4.5	Results of sectoring	43
Table 4.6	Comparing cell splitting and sectoring	43

List of Figures

Figure 1.1	Hypothetical cellular system	1
Figure 1.2	Cellular concept	1
Figure 1.3	Cell Coverage	4
Figure 1.4	Cell shapes	4
Figure 2.1	Universal Terrestrial Radio Access Network (UTRAN) architecture	8
Figure 2.2	CDMA	10
Figure 2.3	Rake receiver	10
Figure 2.4	Median attenuation relative to free space $A_{mn}(f,d)$, over a quasi-smooth terrain	12
Figure 2.5	Correction factor, G_{AREA} , for different types of terrain	13
Figure 2.6	Hypothetical Cell Splitting	13
Figure 2.7	Splitting forms	14
Figure 2.8	Cell splitting power calculations	14
Figure 2.9	Cell sectoring	15
Figure 2.10	Interference reduction with sectoring	15
Figure 2.11	Handover	16
Figure 2.12	Hard handover	17
Figure 2.13	Maximum electric field strength during call	19
Figure 3.1	System deployment	21
Figure 3.2	Initialization phase	26
Figure 3.3	Checking Results functions	28
Figure 3.4	A pseudo code of checking results by tracing	29
Figure 3.5	difference between computer and human dedicated files	30
Figure 3.6	Performed splitting	31
Figure 3.7	Performed sectoring	31
Figure 3.8	Program algorithm	33
Figure 3.9	Microsoft Visual C++ 2008 Express Edition starting page	35
Figure 3.10	Visualization software	35

List of Abbreviations

2G	2 nd Generation
3G	3 rd Generation
3GPP	3 rd Generation Partnership Project
4G	4 th Generation
AuC	Authentication Center
B3G	Beyond 3G
BER	Bit Error Rate
BS	Base Station
BSC	Base Station Controller
BSS	Base Station Subsystem
BTS	Base Transceiver Station
CIR, C/I	Carrier-to-Interference Ratio
DS-SS	Direct Sequence Spread Spectrum
EIR	Equipment Identity Register
ETSI	European Telecommunications Standard Institute
FH-SS	Frequency Hopping Spread Spectrum
FTP	File Transfer Protocol
GSM	Global System for Mobile communications
HO	Handover
HHO	Hard Handover
HLR	Home Location Register
HSDPA	High Speed Data Packet Access
HS-DPCCH	High Speed Dedicated Physical Control Channel
HS-DSCH	High Speed Downlink Shared Channel
HS-SCCH	High Speed Shared Control Channel
ICNIRP	International Commission on Non-Ionizing Radiation Protection

ISI	Inter Symbol Interference
KISS	Keep It Simple Stupid
MMI	Man Machine Interface
MS	Mobile Station
MSC	Mobile Switching Center
NB	Node B
OFDMA	Orthogonal Frequency Division Multiple Access
PER	Packet Error Rate
PSTN	Public Switched Telephone Network
QoS	Quality of Service
SAF	Service Activity Factor
SF	Spreading Factor
SHO	Soft HandOver
SIR , S/I	Signal to Interference Ratio
SMS , sms	Short Message Service
SSHO	Softer HandOver
TDMA	Time Division Multiple Access
TH-SS	Time Hopping Spread Spectrum
UE	User Equipment
UMTS	Universal Mobile Telecommunications System
UTRAN	UMTS Radio Access Network
VLR	Visitor Location Register
WCDMA	Wideband Code Division Multiple Access

Chapter 1 Introduction

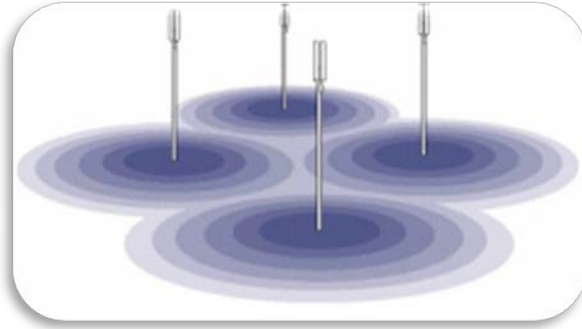

Figure 1.1 Hypothetical cellular system

Mobile wireless communication has become a very important target for cartels and even small enterprises. Each invention either starts or ends in this field. Most of the wireless technologies were originally developed for military purposes only, and after decades they have been revealed to the public; mainly for revenue.

Building up on this progress by governmental and business cartels either in USA, Europe or Japan has led to new generations of mobile wireless communications.

The main reason for this significance of wireless technologies comes from the fact that modern life tends to mobility. The less wires the more freedom to move around without crisscross! As a result cellular market is growing enormously. It has started with few systems serving hundreds of people, then spread to hundreds of networks serving hundreds of millions of subscribers. This huge and rapid increment has pushed a lot on the available resources specially the air interface with its available spectrum, which makes it necessary to recycle! This idea –recycling the spectrum- forms the basis for cellular networks planning.

The land area to be supplied with radio service is divided into regular shaped cells, ideally circular as shown in figure 1.1 and conventionally hexagonal shapes as shown in figure 1.2. Each of these cells is assigned a different frequency, such that no two adjacent cells operate on the same frequency.

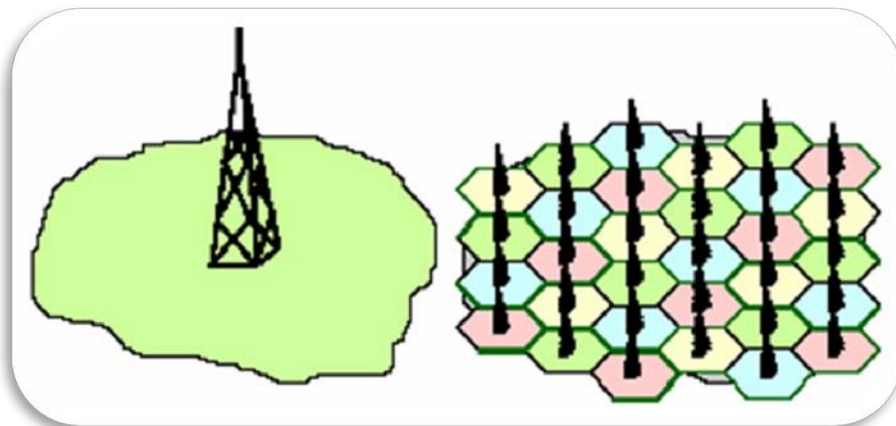

Figure 1.2 Cellular concept

This increased capacity in a cellular network, compared with a network with a single transmitter, comes from the fact that the same radio frequency can be reused in a

different area for a completely different transmission. If there is a single plain transmitter, only one transmission can be used on any given frequency.

Nowadays, there is a rapid increasing demand for internet connection that provides a very high data rate suitable for multimedia purposes either in commercial or individual usage. This generates a problem to the existed cellular networks in fulfilling the needs of the clients quantitatively and qualitatively, that is to connect all requesting clients and provide them with good quality of service (QoS) and reliable connections.

To meet this demand, cellular networks' systems and technologies were developed and adapted to the properties of data communications. Two of the most used techniques are cell splitting and sectoring. Regardless of aiming the same target, they use different concepts. Cell splitting increases the number of base stations (BS) or node Bs (NB) in the given area to increase the system's capacity, while sectoring relies on the placement of base stations' antennas to reduce the co-channel interference, this in turn increases the signal to interference ratio (SIR).

1.1 History

“In 2001, Japan was the first country to introduce a 3G system commercially known as FOMA (Freedom Of Mobile Multimedia Access). It was based on an early version of UMTS standard specifications. Unlike the GSM systems, which developed various ways to deal with demand for improved services, Japan had no 2.5G enhancement stage to bridge the gap between 2G and 3G, and so the move into the new standard was seen as a fast solution to their capacity problems” [1]

In December 2007, 190 3G networks were operating in 40 countries and 154 HSDPA networks were operating in 71 countries, according to the Global Mobile Suppliers Association (GSA). In Asia, Europe, Canada and the USA, telecommunication companies use W-CDMA technology with the support of around 100 terminal designs to operate 3G mobile networks.[2]

Third generation (3G) networks were established using new techniques which have enabled boasting the speed from 144 Kbps to 2.4Mbps.

These 3G networks were also evolved to (3.5G) standard called High Speed Downlink Packet Access (HSDPA) that boosts speeds to 14 Mbps for single-input single-output systems.

Improving the coverage and the capacity of these 3.5G cellular networks is the subject of this thesis. And the required technical details will be discussed later in chapter 2.

1.2 Data Speed

It is important to notice that the speeds offered by advertisements are the theoretical peak limits which assume ideal system. They are not the actual delivered speed for each user.

The maximum achievable bandwidth is significantly affected by cell size. The maximum data rate tends to fall away for users at the edge of the cell. For macro cells the peak aggregate data rate will be in the range of 1–1.5 Mbps. The peak data rate

increases to more than 6 Mbps for the users within a micro cell. Furthermore, a pico cell could get a load data rate of 8 Mbps.[3]

Determination of these peak values is based on a combination of factors including the chip rate, channel structure, power control, and synchronization.

Actual data speeds will vary in accordance with several factors including [4]:

- Number of users in cell/sector
- Distance of the user from the base station
- Whether the user is moving or stationary
- Network operator capacity and network optimization requirements

1.3 Fields of the Research

1.3.1 Splitting the band among File Transfer Protocol (FTP) and Web browsing

File Transfer Protocol (FTP) is the simplest and most secure way to exchange files over the Internet. As the name ‘file transfer’ indicates, the most common use for FTP is to download files from the Internet. Because of this, FTP is the backbone of the MP3 music craze, and vital to most online auction and game enthusiasts. In addition, the ability to transfer files back-and-forth makes FTP essential for anyone creating a Web page, amateurs and professionals alike. [5]

This shows the interrelation between FTP and Web browsing. But unlike web browsing, file transfer needs very high speeds especially for video. Leaving these two services free of control leads to making file transfer consumes the bandwidth; therefore, there is a need for splitting the given band among them to avoid biasing the network since they are using the same resource.

1.3.2 System Capacity

System capacity is defined as the number of simultaneous users that can be supported by the system, when the system is in sufficient blocking level. Increasing system capacity can be achieved by many ways such as cell splitting and sectoring which will be discussed in depth later.

1.3.3 System Coverage

System coverage is the total area that is covered by the whole cells of the system. Each cell covers a specific area. In real life this area as shown in figure 1.4 is neither symmetric nor regular. In ideal case and in some special cases of wide flat areas the shape of the covered area tends to take the ideal shape for omni directional cells. But unfortunately circular cells do not “tessellate”. This is shown in figure 1.5. (A shape is said to tessellate if copies of it can be placed side by side across a piece of paper without leaving any gaps and without any overlap.)

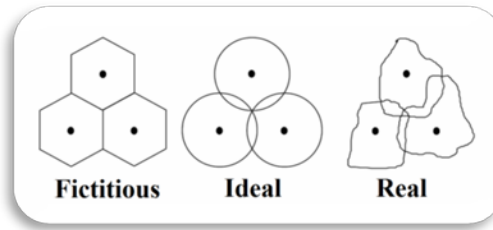

Figure 1.3 Cell Coverage

The hexagonal shape is used for a lot of reasons in planning to simplify drawing. The hexagon has the least angles and the most area that can fit or replace a circle.

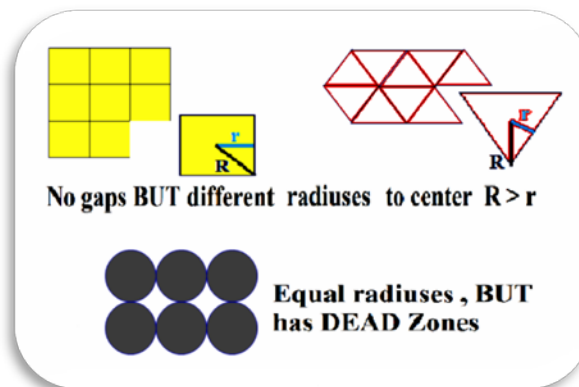

Figure 1.4 Cell shapes

1.3.4 User Satisfaction

User satisfaction is the main objective of most researches, especially the commercials. This objective is well defined scientifically and is not fluctuant according to the mode of the samples under surveys.

According to the “TSG-RAN Working Group 1 meeting #14” [6], a user is classified as satisfied if he fulfills the following conditions:

1. The user does not get blocked when requesting a connection to the system
2. The user has sufficiently good quality more than a predefined value (such as 95%) of the session duration.
3. The user does not get dropped during his communication session.

1.4 Related Researches

There are many researches concerned in High Speed Download Packet Access (HSDPA) cellular network. But before digging deeper, it is highly important to put an emphasis on the fact that all researches agreed on, which is using different simulators leads to different results even using the same parameters. Thus, most of these researches built their own simulators.

As stated in [7], “HSDPA network performance and behavior will depend on the algorithms used to implement HSDPA link adaptation, scheduling, power control, and other radio resource control mechanisms... these algorithms are vendor specific. No

algorithm is standardized and hence HSDPA network performance and behavior will also be vendor specific”.

It is also stated in [8] that “Especially in packet-data-driven networks, like HSDPA, the system-level performance strongly depends on the algorithms in use”.

Finally, the same fact is stressed on [9], “Because the different simulators use different random number generators and the model implementations differed slightly (e.g., the different packages use different means to specify network traffic), statistical results from the different packages were not identical”.

Some researchers build their own simulators for other reasons. One reason is that those existed solutions are specific for the implemented algorithms and for the simulated environment [7]. Another reason is that the models available in literature do not cover new features and trends so far. And many of them lack sufficient accuracy, analytical applicability, or computational efficiency [8].

Most of the researches do not cover all the topics exposed in this thesis. They just study the effects of varying one parameter, applying one modification or one technique. Then, by the way, point to our subject with a small note [10][11][12][13][14][15][16]. That is, there are no previous works do explicitly the work done in this thesis.

In [10], where it talks about “the effect of non-uniform user traffic distributions on the performance of a CDMA cellular system”. The researcher comes with the following conclusion that is related to our research “The results indicate that the majority of the total multi-user interference experienced by any user in the network is from the intra-cell users. As expected, if the percentage of intra-cell users in the network is decreased by cell splitting, the system performance improves” [10]. However, the paper did not say how much improvement they have achieved as the main studied topic was the distribution of the users not the cell splitting.

In [11], the researcher explores another variation to increase the capacity and coverage of the reverse link. This variation is the increased diversity order using spatially separated, polarized antennas at the base station receiver of a CDMA cellular system.

The researcher in [12] tries another variation regarding sectoring. He uses two kinds of sectoring; fixed and optimized. In the first, the angles of the sectors are fixed, while in the latter the angle is adoptive and variable according to the distribution of the users throughout the cell. The researcher comes with the following conclusion “On the other hand, the capacity in the case of non-optimized sectoring is very sensitive to the non uniformity of user distribution across cell such that the capacity improvement for a 3-sector case over an omni-directional case is between 1.8 to 3, depending on the user distribution among sectors”. This result is close to ours, where the capacity improvement for a 3-sector case over an omni-directional case is 1.82 and the maximum limit is 3.

In [13], the researcher tries to increase capacity by minimizing errors in transmission, which reduces the need for retransmission and increases served users. That is the researcher tries to increase capacity by optimizing the radio resources, and comes with the following conclusion: “With implementation of these error concealment methods the same video quality can be achieved using a lower E_b/N_o which in turn provides flexibility for network operator to increase the number of users”. But “This implementation obviously requires some processing overhead on both the encoder and decoder sides”.

Ref [14] supposed to provide an opportunity to study the sectoring technique while using different multiple access scheme which is Orthogonal Frequency Division Multiple Access (OFDMA), but results do not add so much when the researcher comes with the conclusion: “Further, sectoring reduced co-channel interferers and resulted in a better system outage probability performance”.

Ref. [15] provides a simplified analysis to show that a system without power equalization performs better than a system with power equalized users. But “since a system that has no power equalization at all does not make sense” the researcher proposes a combined model in which users with strong channels, in this case close users, are equalized and the users with weak channels are not. “The proposed model improves a lot the performance of the equalized system and at the same time is fairer for the users”.

Also in [16], while it is talking about “Performance of UMTS Handover by Cell Sectorization Using Opnet Modeller”, the researcher states this “Although there is another way to increase system capacity is by “Cell Splitting”, sectorizing is less expensive than cell splitting...Expensive cell splitting **more likely** to be avoided in LTE (Long term Evaluation) solution due to significantly less radio resources required rather than legacy technologies” [16].

As shown above, the only note about comparing cell splitting and sectoring was not the field of the research and was not justified by simulations and results. It was an individual opinion followed by an individual expectation.

Regardless of the accuracy of the comparison, the note explains the rush towards sectoring, which is cheapness.

In this research, we built our own simulator widening some limitations exist in others. For example mobility is assured by giving each user a random constant velocity (random speed and random direction). It is not variable as real life, but it is more realistic than a fixed 3 kmph for all users as in [8].

Also, exclusive simulations are done to study the effects of varying the radial mode, varying Service Activity Factor (SAF), cell splitting and sectoring. Then a comparison was made between cell splitting and sectoring. This study is done by measuring a predefined performance metrics.

1.5 Objectives

As the number of users of the 3.5G cellular network increases, the quality of service degrades and the coverage area shrinks. This phenomenon is called Cell breathing. It is a fundamental property of CDMA.

Thus our objectives are:

- Building a simulation platform
- Building the initial 3.5G cellular network under band splitting between File Transfer Protocol (FTP) and Web browsing.
- Taking the parameters of interest that specify the performance of the 3.5G cellular network. These parameters are stated in the previous section.

- Improve coverage and system capacity of the cellular system either by modifying the parameters of the 3.5G cellular network or by modifying the network itself.
This change is measured and the improvement is verified by comparing the network's parameters of interest before and after modification.
- Improve the user satisfaction based on the scientific rules stated in the previous section.
This change is measured and the improvement is verified by comparing the network's parameters of interest before and after modification.

1.6 Thesis Contributions

The main contributions of the thesis:

- Designing a system level Simulation Platform from scratch, that is starting just with ideas and without using any existing telecommunications software.
- Increasing the performance of the existing cellular network through varying some parameters.

First, the redial process is varied from no redial at all, to delayed redial, then to allowed redial with no restrictions at all.

Second, the Service Activity Factor (SAF) is varied for web users from 60% of the allowed transmission rate of the node B to 50%, which results in varying the service activity factor for FTP users from 40% to 50%. Then the redial process is varied again.

- Increasing the performance of the cellular network by the most important techniques for recycling the available spectrum; cell splitting and sectoring.
- Increasing the satisfied users by increasing the performance of the cellular network.
- Studying the radiation effects of each technique. That is comparing the in-cell users' interference and node Bs' transmitted power when using splitting and sectoring.

Note that:

1. Performance metrics under study -before and after modifications- are number of successful connections, blocking rate, handovering rate, disconnecting rate and the quality of service.
2. Any change in the 3.5G cellular network's parameters -either a decrement or an increment- after modification is measured relative to the original state of the network. So improvements are measured under the same conditions by the previously mentioned metrics.
This is typical. The comparisons are made between the original case and the modified case NOT between an original case in other papers and the modified case in this thesis!

3. “Network management system level statistical optimisation aids the operator to control, visualise, analyse and optimise the mobile network using both performance data and configuration data on a network-wide basis” [17].
4. The system level simulation can be used in fine-tuning the network configuration parameters and studying the required aspects in abstract without the disturbances of other aspects, while the link level simulation deals with the physical properties such as generation of signals, signal shaping, signal modulation, signal power, signal detection and other propagation problems[18].

1.7 Thesis Organization

Chapter 2 talks about the backbone theory needed to solve the problem. This chapter states what other books and researches are saying only. Some points may seem irrelevant but they are important. To not mixing things, the relation is not stated. Otherwise the researcher’s implementation and results will be mixed with backbone theory!

Chapter 3 talks about the solutions to the problem, the decisions that were taken and how the solution was implemented.

Chapter 4 includes the significant results produced by running the simulation platform. First, the results are stated or visualized. Then, the analysis of these results follows.

Chapter 5 states the conclusion after analyzing the results. Then it suggests some future development either in the related theoretical part of the research or in the simulation platform itself.

Chapter 2 Backbone Theory

2.1 Third Generation Cellular Network (3G)

“3G systems consist of the two main standards, CDMA2000 and W-CDMA, as well as other 3G variants such as NTT DoCoMo's Freedom of Mobile Multimedia Access (FOMA) and Time Division Synchronous Code Division Multiple Access (TD-SCDMA) used primarily in China” [4].

Figure 2.1 shows the architecture of the 3G cellular network. “Basically, the network can be split in three parts, (i) the UE or terminal connected via the Uu interface, (ii) the Universal mobile telecommunications system Terrestrial Radio Access Network (UTRAN), including everything from the Node B to the serving RNC, and (iii) the core network, connected via the Iu interface, that establishes the link to the internet. Within the UTRAN, several Node Bs -each of which can control multiple sectors- are connected to the drift RNC via the Iub interface” [8]. In the following sections just the related components will be discussed.

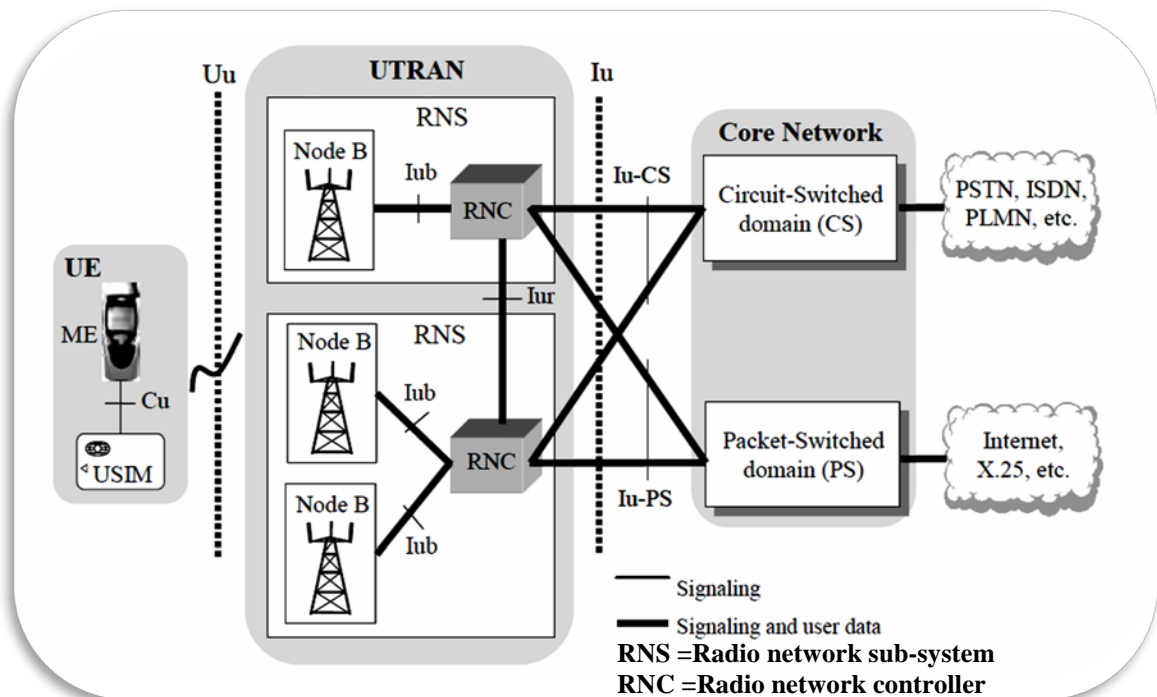

Figure 2.1 Universal Terrestrial Radio Access Network (UTRAN) architecture[1]

2.1.1 User Equipment (UE)

In the Universal Mobile Telecommunications System (UMTS), **user equipment (UE)** is any device used directly by an end-user to communicate. It connects to the 3G Base Transceiver Station (Node B). It is not a simple mobile phone but rather, a mobile multimedia terminal able to provide simultaneously voice, video and data services. The UMTS standards do not impose the physical aspect of the UE.

From a functional point of view, the UE is composed of two parts, the Mobile Equipment (ME) and the Universal Subscriber Identity Module (USIM). The reference point bounding ME/USIM functions is referred to as “Cu” [1].

Handover decisions are mobile assisted. In mobile assisted handover (MAHO), every mobile (UE) measures the received power from the neighboring node Bs, and continually reports them to the serving node B. A handover is initiated when the power received from a neighboring node B exceeds the power received from the currently serving node B [19].

2.1.2 Node B

Node B is a term used in UMTS equivalent to the base transceiver station (BTS) description used in GSM. Node B is the exchange node between the UTRAN and all the UEs located in the cell or sectors covered by Node B. As in all cellular systems, such as UMTS and GSM, the Node B contains radio frequency transmitter(s) and the receiver(s) used to communicate directly with mobile devices, which move freely around it. In this type of cellular network, the mobile devices cannot communicate directly with each other but have to communicate with the Node B.

Thus no need for other than a UE and node Bs. The core network and its details are beyond the scope of this thesis.

2.2 High-Speed Downlink Packet Access (HSDPA)

2.2.1 Need for HSDPA

Two-way voice communications are essentially “symmetric” in their use of radio, while data communications are “asymmetric”. Many 3G mobile services create more traffic going to the user (downlink) than coming from the user (uplink), since web browsing, downloading, and games use the uplink just to send controlling signals or directors while most of the data transfer is done down to the user. This problem forced the designers to accommodate the new specifications of existing 3G cellular networks to meet these new needs and trends.

The solution was done through what is known as High-speed downlink packet access (HSDPA) that was included in Release 5 in Third Generation Partnership Program (3GPP) standards, and it is the most important part of it.

It is clear that HSDPA is not suitable for applications with very low bandwidth requirements, such as voice. HSDPA channels employ spreading factor 16, and using that kind of high-capacity channel for voice is clearly a waste of resources.

2.2.2 Deploying HSDPA

The HSDPA scheme adds an additional wideband downlink shared channel that is optimized for a very high-speed data transfer. It increases both the system capacity as a whole, and the data rate that can be allocated for one user. The maximum theoretical data rate for one user is 14.4 Mbps for single input single output systems.

2.3 Code Division Multiple Access (CDMA)

In a CDMA system all users occupy the whole given frequency, and their signals are separated from each other by means of a special code (see figure 2.2). There are several methods used to modulate CDMA signals such as Direct Sequence (DS-SS), frequency hopping (FH-SS), and Time Hopping (TH-SS)

CDMA systems have the property of accepting users. But as the number of users increases, the quality of signal degrades and the coverage area shrinks. This is a fundamental property of the CDMA systems and called Cell Breathing.

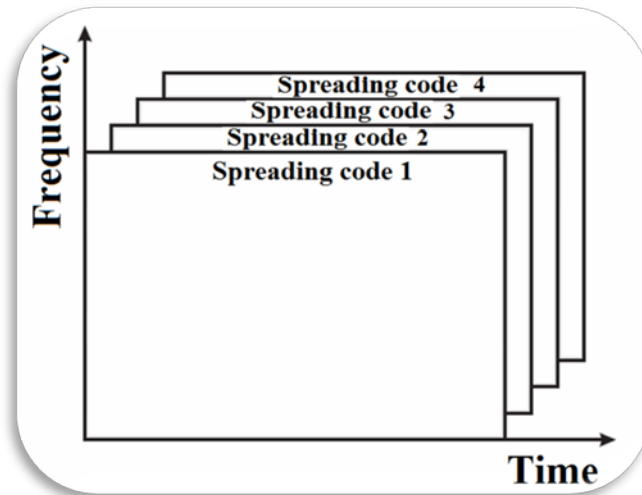

Figure 2.2 CDMA

Direct-Sequence Spread Spectrum (DS-SS) modulation

In (DS-SS) modulation the modulated signal occupies the whole carrier bandwidth all the time as shown in figure 2.2. This scheme is the chosen one by the Third Generation Partnership Project (3GPP) Universal Mobile Telecommunications System (UMTS) Terrestrial Radio Access Network (UTRAN).

The spread high-speed bit or data sequence is referred to as chip or chips to distinguish it from the bit or the data sequence of bits which is called symbol or symbols, and the rate at which the spread data varies is called chip rate. The ratio of chip rate to symbol rate is called the Spreading Factor (SF) or the spreading gain. [20]

2.4 Rake Receiver

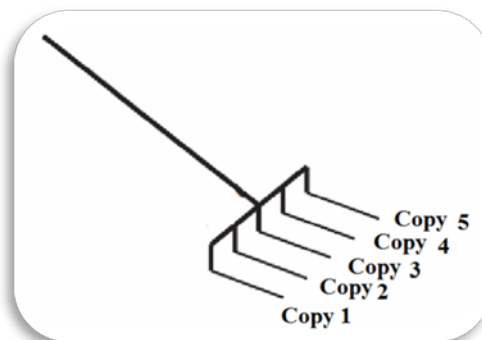

Figure 2.3 Rake receiver

The received attenuated signal will be improved if the receiver got replicas of the signal and combined them together. This can be done by a lot of techniques. However these methods are so complicated. The solution is in the nature of the multipath channel, which provides copies of the original signal with different delays at the receiver. These copies appear because the original transmitted signal reflects off

obstacles in its way. These multipath signals can be received and constructively combined using a Rake receiver as shown in figure 2.3.

2.5 Radio signals propagation

2.5.1 Free space propagation

The signal strength - when travels in free space and is not affected by any other objects or areas - is inversely proportional to the square of the distance from the source to the receiver. Equation 2.1 is true for ‘free space propagation’.

$$P_r = P_t \frac{G_r G_t \lambda^2}{(4\pi d)^2} \quad (2.1)$$

where P_r Received power
 P_t Transmitted power
 G_r Receiver antenna gain
 G_t Transmitter antenna gain
 λ wavelength in m
 d separation distance T-R in m

In real life, the signal dies away at a much faster rate due to the obstacles. Often it is closer to a rate proportional to $1/d^n$, where n is defined as the loss exponent, which depends mainly on the terrain of the area around the base station. The most common values of n for urban areas are 4 or 3.8 and typically a figure of this order will be used when planning a cellular network.[21]

2.5.2 Okumura Model

Okumura’s model is one of the most widely used models for signal prediction in urban areas. This model is applicable for frequencies in the range 150 MHz to 1920 MHz (although it is typically extrapolated up to 3000MHz).

Okumura developed a set of curves giving the median attenuation relative to free space (A_{mu}), in an urban area over a quasi-smooth terrain with a base station effective antenna height (h_{te}) of 200 m and a mobile antenna height (h_{re}) of 3 m. these curves were developed from extensive measurements using vertical omni-directional antennas at both the base and the mobile, and are plotted as a function frequency and as a function of distance from the base station.

To determine path loss using Okumura’s model, the free space path loss between the points of interest is first determined, and then the value of $A_{mu}(f,d)$ (as read from the curves in figure 2.4) is added to it along with the correction factors to account for the type of terrain. The model can be expressed as

$$L_{50}(\text{dB}) = L_F + A_{mn}(f,d) - G(h_{te}) - G(h_{re}) - G_{AREA} \quad (2.2)$$

where L_{50} is the 50th percentile value of propagation path loss
 L_F is the free space propagation loss
 A_{mn} is the median attenuation relative to free space
 $G(h_{te})$ is the base station antenna height gain factor
 $G(h_{re})$ is the mobile antenna height gain factor
 G_{AREA} is the gain due to the type of environment

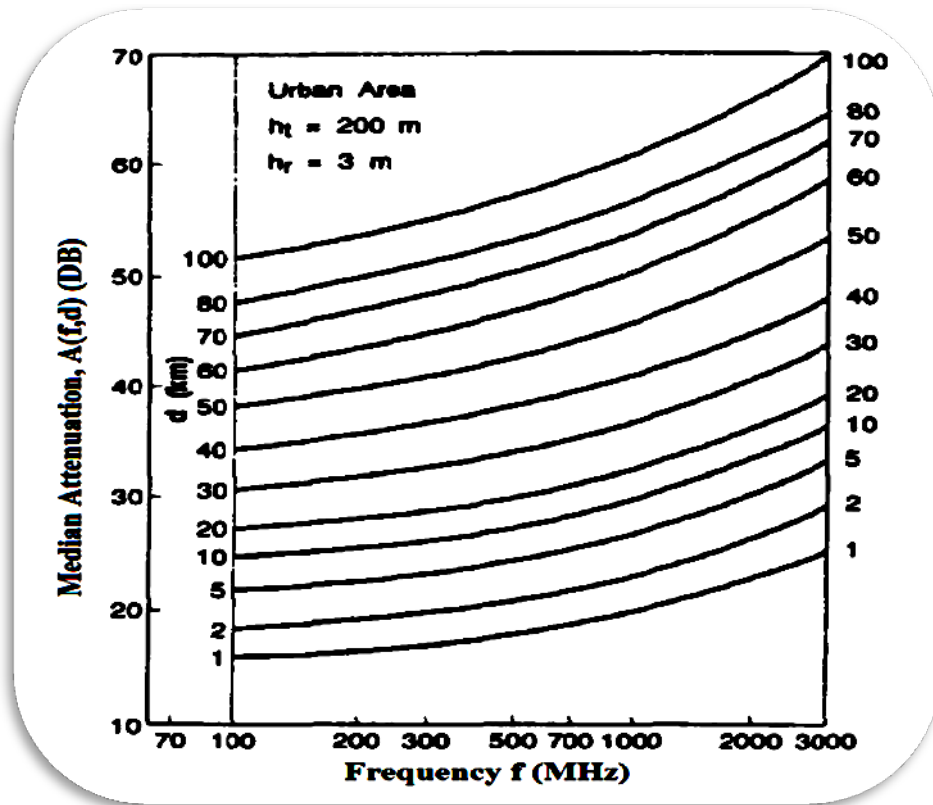

Figure 2.4 Median attenuation relative to free space $A_{mn}(f,d)$, over a quasi-smooth terrain[19]

Okumura also found that the correction of the base station antenna height gain factor

$$G(h_{te}) = 20\log(h_{te}/200) \quad 1000 \text{ m} > h_{te} > 30 \text{ m} \quad (2.3)$$

And the corrections of the mobile antenna height gain factor

$$G(h_{re}) = 10\log(h_{re}/3) \quad h_{re} \leq 3 \text{ m} \quad (2.4-a)$$

$$G(h_{re}) = 20\log(h_{re}/3) \quad 10 \text{ m} > h_{re} > 3 \text{ m} \quad (2.4-b)$$

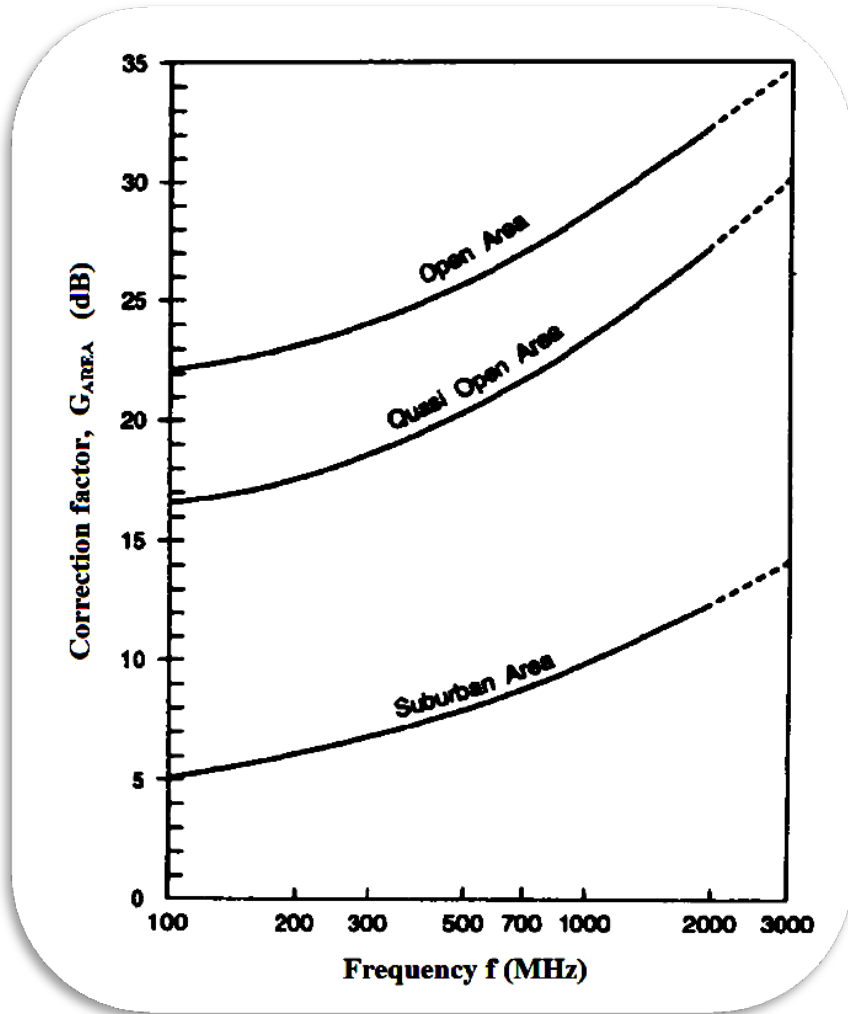

Figure 2.5 Correction factor, G_{AREA} , for different types of terrain [19]

2.6 Cell splitting

Cell splitting is the process of splitting or dividing a radio coverage area of a congested mobile cell into several smaller coverage areas of smaller mobile cells with corresponding reduction of antenna height and transmitter power as shown in figure 2.6.

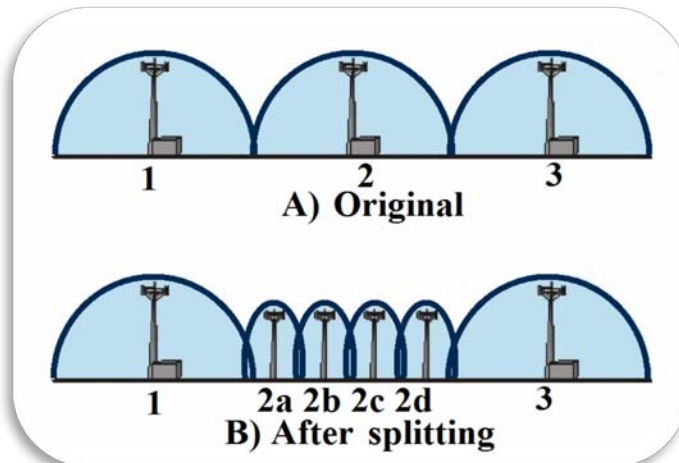

Figure 2.6 Hypothetical cell splitting

Cell splitting has been one of the principal means by which cellular telephone operators increased the capacity of their networks, and it will also be a standard tactic for broadband wireless operators. This increment of capacity comes from allowing the system to reuse its resources either the used frequencies, time slots or codes.

Cell splitting as shown in figure 2.7 can take many forms, there are no restrictions on the form of splitting.

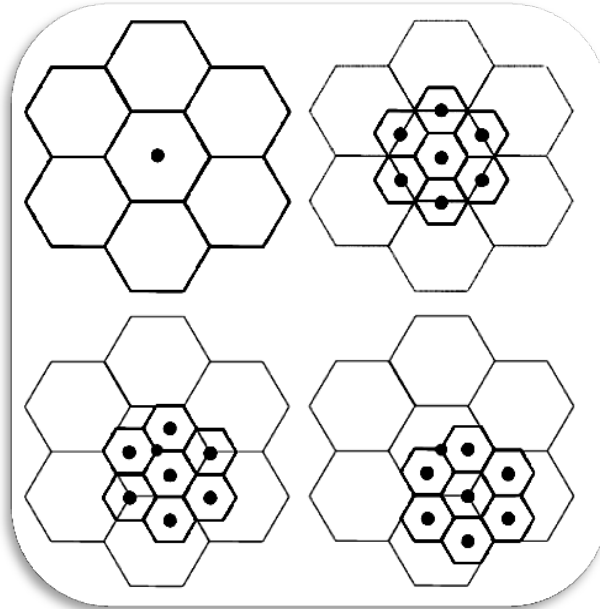

Figure 2.7 Splitting forms

The restrictions come to the transmitted power and the antenna's height. The antenna after splitting is lowered so that the coverage area is smaller to reduce or prevent interfering adjacent cells as shown in figure 2.6. The transmitted power is lowered also to avoid interfering adjacent cells. This reduction of power can be calculated as follows [19]:

$$Pr \propto \frac{Pt}{d^n} \quad (2.5)$$

where Pr is the received power,
 Pt is the transmitted power
 d is the distance between transmitter and receiver.

Since at the border the power received before splitting must be the same, then

$$Pr_1 = Pr_2 \rightarrow Pt_2/Pt_1 = (d_2/d_1)^n = (1/2)^n \rightarrow Pt_2 = Pt_1 \left(\frac{1}{2}\right)^n$$

$$\text{If } n = 4 \text{ as mentioned in chapter 2 section 3} \rightarrow Pt_2 = Pt_1 \left(\frac{1}{16}\right)$$

Figure 2.8 Cell splitting power calculations

In practice the cells do not go up and down to change the height. Instead, the transmitted power is reduced as shown in figure 2.8. Also not all cells split at the same time. That is only the congested cell is splitted while others remain unchanged. That is why we kept the power constant at borders before and after splitting. This process continues with congested cells till all the cells are splitted and the system is rescaled.

2.7 Cell Sectoring

Sectoring is a standard practice in most cellular systems. It increases the capacity of the system without changing the borders of the cell by decreasing the interference.

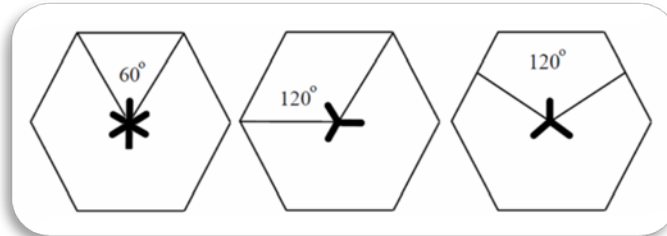

Figure 2.9 Cell sectoring

One way of cutting the interference is to use several directional antennas at the base stations, with each antenna illuminating a sector of the cell. Every sector field can therefore be considered like one new cell.

60° and 120° cell sectoring are commonly employed as shown in figure 2.9. It reduces the number of prime interference sources to one and two respectively. This is shown clearly in figure 2.10[19], where out of the six cells numbered 5 in the first tier; surrounding the central cell numbered 5; just one sector of two cells only are interfering with the central cell 5, while the other sectors of the cells are directed away. If omni directional antennas were used, then all the six cells would interfere.

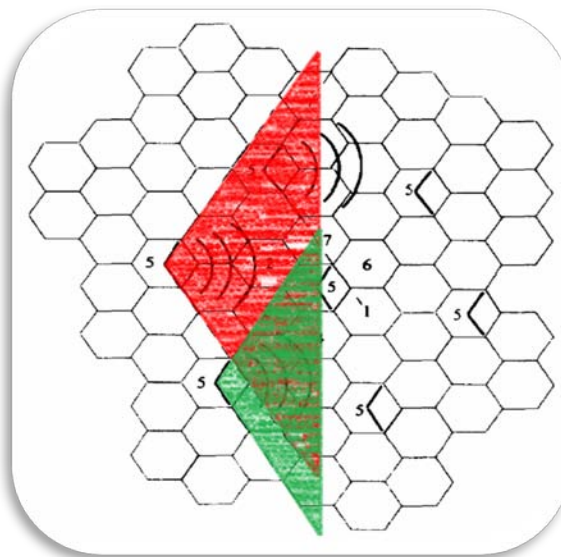

Figure 2.10 Interference reduction with sectoring

2.8 Performance metrics

2.8.1 Percentage of Unsatisfied Users

It was mentioned before (chapter 1.3.3) the three conditions that count the user as satisfied user. These three conditions can be measured by monitoring some statistics [22].

- **Blocking Rate:** The ratio of the number of users that are denied access to the system to the total number of users in the system. Blocking occurs when a user arrives at the system and there are no sufficient system resources to satisfy the user's Quality of Service (QoS) requirements.
- **Users' Throughput:** The number of successfully sent bits in a specific period of time.
- **Dropping Rate:** The ratio of the number of dropped users to the total number of the users in the system. Dropping occurs due to handover failure, when user's throughput remains below the service's QoS requirement for certain duration of time.

2.8.2 Handover Rate

Handover (HO) is the European term for the process of moving the connection of UE from one Node B to another Node B, or from one sector of the Node B to another sector of the same Node B in case of sectoring. The American term is Handoff. The idea is better cleared by figure 2.11 [19]

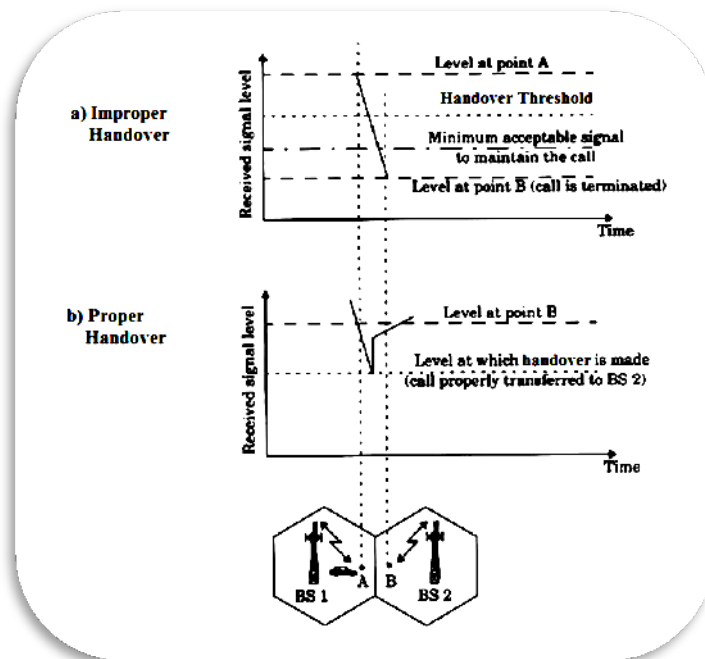

Figure 2.11 Handover [19]

Handover rate is the ratio of the number of users that performed handover during a simulation run to the total number of users in the system.

Handover is not one type. It has different types according to the place where it occurs and how it occurs.

Handovers in Code Division Multiple Access (CDMA) are fundamentally different from handovers in Time Division Multiple Access (TDMA) systems. While an HO in a TDMA system is a short procedure, and the normal state of affairs is a non-HO situation, the situation in a CDMA system is dramatically different. A UE

communicating with its serving network can spend a large part of the connection time in a soft handover (SHO) state [23].

2.8.2.1 Soft Handover (SHO)

In a soft handover (SHO), a UE is connected simultaneously to more than one base station. The UE receives the downlink transmissions of two or more base stations. For this purpose it has to employ one of its Rake receiver fingers for each received base station. Note that each received multipath component requires a Rake finger of its own. Each separate link from a base station is called a **soft handover branch**. Indeed, from the point of view of the UE, there is not much difference between being connected to one base station or several ones; even in the case of one base station, a UE has to be prepared to receive several multipath components of the same signal using its Rake receiver. As all base stations use the same frequency in an SHO, a UE can consider their signals as just additional multipath components.

An important difference between a multipath component and an SHO branch is that each SHO branch is coded with a different spreading code, whereas multipath components are just time-delayed versions of the same signal.

SHO is typically employed in cell boundary areas where cells overlap. It has many desirable properties. In the cell edges, a UE can collect more signal energy if it is in SHO than if it has only a single link to a base station. Without SHO, a communicating base station would have to transmit at a higher power level to reach the UE, which would probably increase the overall system interference level. Additionally, if a UE is in SHO, the connection is not lost altogether if one branch gets shadowed [23].

2.8.2.2 Softer Handover

A softer HO is a HO between two sectors of a cell. From a UE's point of view it is just another SHO. The difference is only meaningful to the network, as a softer HO is an internal procedure for a Node B, which saves the transmission capacity between Node Bs and the Radio Network Controller.

2.8.2.3 Hard Handover

Hard handover (HHO) is also known as an interfrequency handover. During an HHO the used radio frequency of the UE changes. This is shown in figure 2.12.

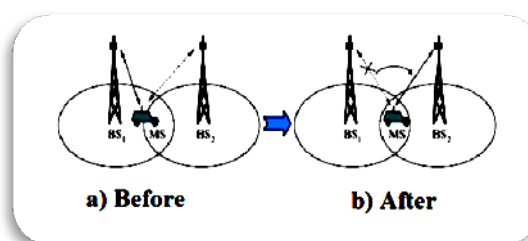

Figure 2.12 Hard handover

In principle, an HHO is a so-called break-before-make handover; that is, it is not seamless. The UE stops transmission on one frequency before it moves to another frequency and starts transmitting again.

2.8.2.4 Intersystem Handovers

Intersystem HOs are HOs between two different radio access technologies. Intersystem HOs are especially difficult procedures. There are plenty of problems that must be solved before such an HO is possible. A prerequisite for this procedure is that we have a dual-system 3G-GSM mobile phone capable of communicating with both systems.

2.9 Doppler Shift

When the user (UE) is stationary, there is no difference between received waves or signals. But when UE is moving then the position and angle of reception and time required is changing. Amount of change depends upon the velocity (speed and direction).

$$f_d = \frac{v}{\lambda} \cos\theta \quad (2.6)$$

where v is UE velocity
 θ is spatial angle between direction of motion of UE
and direction of wave arrival

It is clear that if the UE is moving towards the wave source (Node B), then the Doppler shift will be positive which means that the apparent received frequency is increased. And if UE is moving away then the Doppler shift will be negative, so the apparent received frequency is decreased.

“For a realistic performance evaluation, the simulated UEs in the target cell have to move. Accordingly, I implemented a random movement mobility scheme. At the beginning of a simulation a random position in the target sector according to a uniform probability distribution over the sector area is assigned to each user. Additionally, every user is assigned a random walking direction with uniform distribution over the interval $[0, 2\pi)$ ” [8].

2.10 Radiation Exposure

The issue isn't if people are exposed or not! The issue is how much exposure is “safe”. Cell phones give low levels of RF when they are in use and they also give off very low levels of RF in standby mode. But according to a recent research; Maximum electric field strength in the vicinity of the mobile phones measured during the incoming and outgoing call mode with the phone backing the probe was shown in figure 2.13. During this mode, the highest and lowest readings of the electric field strength are at 53.40 and 15.20 V/m, as demonstrated by brand SN1 and brand NK4 respectively. This is because during that time the mobile phones are trying to hook up to a nearby base station and subsequently reaching out to the desired base station of which is nearest to the call destination. [24]

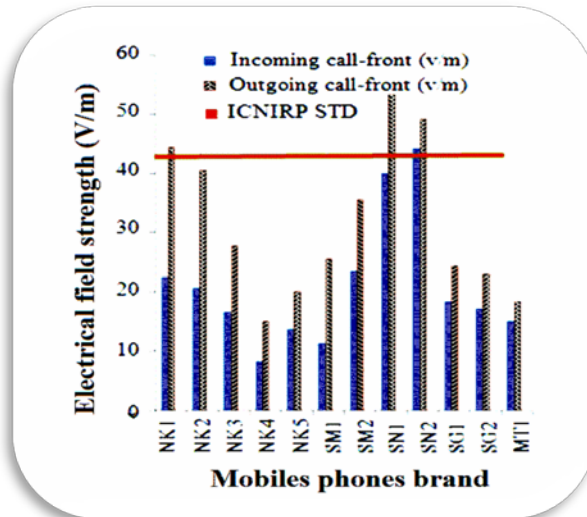

Figure 2.13 Maximum electric field strength during call[24]

When a human body is exposed to the electromagnetic radiation, it absorbs radiation, because human body contains 70% of liquid. It is similar to that of cooking in the microwave oven. The human height is much greater than the wavelength of the cell tower transmitting frequencies, so there will be multiple resonances in the body, which creates localized heating inside the body. This results in boils, drying up the fluids around eyes, brain, joints, heart, abdomen, etc

The current international standards -based on International Commission on Non-Ionizing Radiation Protection (ICNIRP) recommendations- are purely based on the thermal effects of radiation where as various epidemiological and experimental studies have shown to have significant biological effects far below these standards. Non-thermal effects of Radio frequency radiation accumulate over time and the risks are more pronounced after 8 to 10 years of exposure.[25]

2.11 Programming Language

The simulation platform was done in C++.

Chapter 3 System Implementation

“The success of a model is not only determined by its scientific appeal and accuracy, but also by its simplicity. Models are not only used by their designer but also by many others. Thus simpler models are much easier to explain and understand, and consequently their acceptance in the scientific community is usually larger. However—as Albert Einstein already pointed out—one should not forget the following:

“Make everything as simple as possible, but not simpler.” [8]

The implementation of the objectives was affected mainly by two major principles in engineering; the first is ‘do what is necessary and avoid all the unnecessary efforts’. That is to implement the band splitting, the cell splitting and sectoring, there must be a whole system. Wholeness here does NOT mean a complete system with irrelative components and protocols. But rather it means a complete system with all the necessary components. For example the search studies the congested cell behavior and the options to solve this congestion by cell splitting or sectoring, this neither needs designing, coding nor simulation of power control schemes.

The second principle is “Keep It Simple Stupid (KISS)”. That is if a goal can be achieved by many methods, then the one with simplest design, code and/or implementation is chosen. The more complex is the solution; the more it is exposed to error risks.

Keeping these two important guides does not mean at all that the solution is closed. Or it can not be developed further. The implementation goes on what is necessary to accomplish the objectives, leaving a space for future developments and refinement. The same example mentioned above; the power control scheme is put here. Regardless of not considering the power control process in this thesis, but the power values holders do exist, and some values are calculated.

The main features of the implementation are listed in the following sections.

3.1 Network Management System Level Simulation

A number of parameters were defined to reflect the services. Then the results were taken for the specified services, and the performance metrics were computed, without any use of physical level such as generation of pulses, or behavior of filters, also without interfering our focus on the specified parameters with propagation problems. In other words the focus was on the behavior of the whole system and the effects of management of the network parameters.

3.2 Dynamic System Simulation

One way to model the network behavior is to use dynamic system simulations with quite realistic models for aspects of interest and effects (mobility, soft handover, disconnecting users ...), and to simulate the time-variant behavior of the network. Detailed results can be obtained using this method. Some authors argue that dynamic simulation is very time consuming. And it’s mainly used to validate or optimize small parts of the network or to perform parameter studies to tune the network settings [26]. This argument agrees with our case here ‘Perform parameter studies’!

3.3 Simulation Session

Each simulation session lasts for 210 seconds that's 3.5 minutes. This time is NOT the running time or the time period between starting and finishing simulation! So it is NOT machine dependent. It can be further extended, but since we reach the state of interest it will be a waste of resources time, computer computations and memory and the human efforts.

In each simulation session the network is studied with fixed and variable parameters of interest.

3.3.1 Deployment

The simulating program adopted the system with 19 cells (Node Bs) arranged in three tiers. The first is Node B 0, the second is composed of the Node Bs 1,2,3,4,5 and 6. The third tier is composed of Node Bs 7,8,9,10,11,12,13,14,15,16,17and 18.

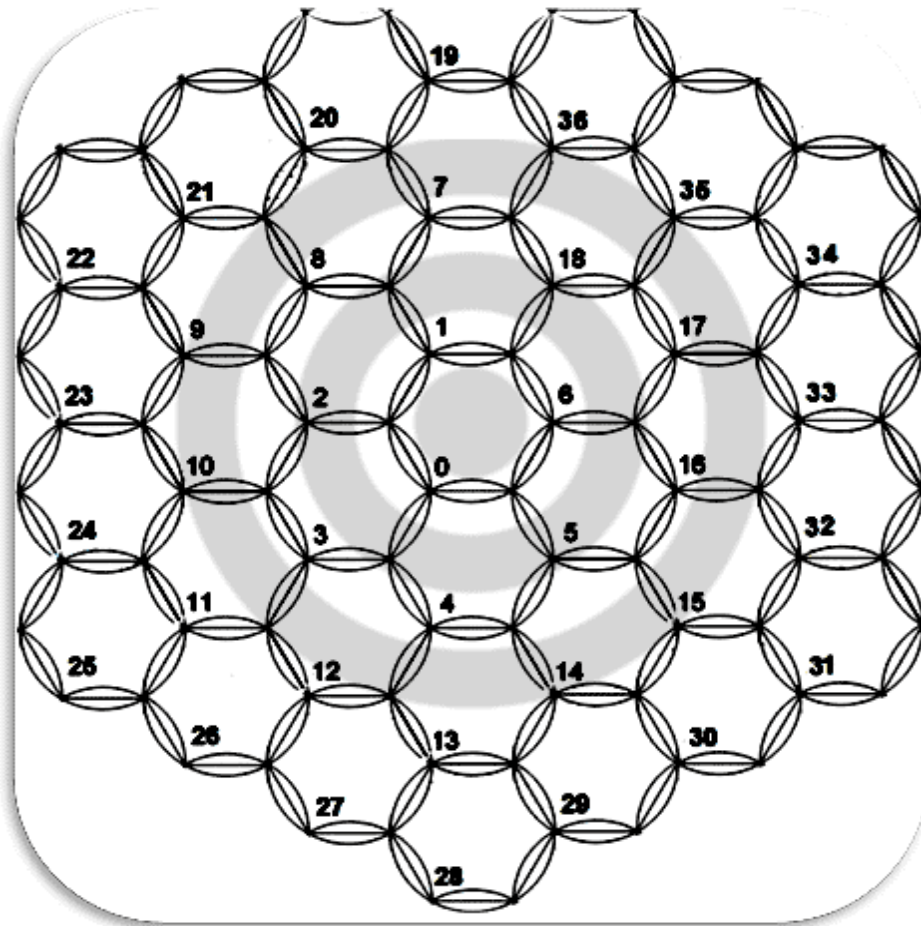

Figure 3.1 System deployment

As mentioned in chapter 2, the hexagon is the adopted shape to represent the cell or Node B. But the circles are presented here just to emphasize the fact of overlapping regions for handover.

Sometimes the program referred to higher tiers just to keep place and feed the Node Bs with correct data about their neighbors. This was especially done at the last tier. This is shown in table 3.1.

The main cell of interest was cell 0 (Node B 0), because this cell would be studied further for cell splitting and sectoring.

Table 3.1 Node Bs and their adjacent

NB[0].id adj_NB 1 adj_NB 2 adj_NB 3 adj_NB 4 adj_NB 5 adj_NB 6	0	NB[1].id adj_NB 0 adj_NB 2 adj_NB 6 adj_NB 7 adj_NB 8 adj_NB 18	1	NB[2].id adj_NB 0 adj_NB 1 adj_NB 3 adj_NB 8 adj_NB 9 adj_NB 10	2
NB[3].id adj_NB 0 adj_NB 2 adj_NB 4 adj_NB 10 adj_NB 11 adj_NB 12	3	NB[4].id adj_NB 0 adj_NB 3 adj_NB 5 adj_NB 12 adj_NB 13 adj_NB 14	4	NB[5].id adj_NB 0 adj_NB 4 adj_NB 6 adj_NB 14 adj_NB 15 adj_NB 16	5
NB[6].id adj_NB 0 adj_NB 1 adj_NB 5 adj_NB 16 adj_NB 17 adj_NB 18	6	NB[7].id adj_NB 1 adj_NB 8 adj_NB 18 adj_NB 19 adj_NB 20 adj_NB 36	7	NB[8].id adj_NB 1 adj_NB 2 adj_NB 7 adj_NB 9 adj_NB 20 adj_NB 21	8
NB[9].id adj_NB 2 adj_NB 8 adj_NB 10 adj_NB 21 adj_NB 22 adj_NB 23	9	NB[10].id adj_NB 2 adj_NB 3 adj_NB 9 adj_NB 11 adj_NB 23 adj_NB 24	10	NB[11].id adj_NB 3 adj_NB 10 adj_NB 12 adj_NB 24 adj_NB 25 adj_NB 26	11
NB[12].id adj_NB 3 adj_NB 4 adj_NB 11 adj_NB 13 adj_NB 26 adj_NB 27	12	NB[13].id adj_NB 4 adj_NB 12 adj_NB 14 adj_NB 27 adj_NB 28 adj_NB 29	13	NB[14].id adj_NB 4 adj_NB 5 adj_NB 13 adj_NB 15 adj_NB 29 adj_NB 30	14
NB[15].id adj_NB 5 adj_NB 14 adj_NB 16 adj_NB 30 adj_NB 31 adj_NB 32	15	NB[16].id adj_NB 5 adj_NB 6 adj_NB 15 adj_NB 17 adj_NB 32 adj_NB 33	16	NB[17].id adj_NB 6 adj_NB 16 adj_NB 18 adj_NB 33 adj_NB 34 adj_NB 35	17
		NB[18].id adj_NB 1 adj_NB 6 adj_NB 7 adj_NB 17 adj_NB 35 adj_NB 36	18		

3.3.2 Propagation model

To overcome power calculation issues, the adopted system uses a fixed number of users that the Node B can not exceed. As a result the interference is limited and the quality of service is perfect, without calculating power, interference, C/I and SIR. This is stated explicitly when initializing the threshold value.

As stated in chapter 2 section 3, Okumura's model is one of the most widely used models for signal prediction in urban areas. Anyway, "This simulator has clear simplifications. To start with, the air interface and its effects are omitted since it is supposed that air conditions are similar for all users" [7]. To simplify the matters an n of order 4 was adopted.

3.3.3 Random Sample of Users

One parameter that was set early and kept constant along all the simulations was the random sample of users. This was done to be sure that there are no side effects due to changes in the sample under study.

There were two ways to keep the sample after generation, one by writing all the users with their attributes to a file, then retrieving them when need either for taking readings or modifying. This choice may sound pretty, but it needs a lot of allocated memory. Also, because of the relatively huge size of the sample, it requires a huge number of times of opening, retrieving, modifying and closing files.

The second way was generating the users at the beginning of each simulation session dynamically, then retrieving and modifying them as necessary to the simulation. Obviously this was the choice! Since all the calculations are done in either way, why bothering saving to files, retrieving files and a lot of unnecessary coding. The matter according to the second guideline must be kept SIMPLE.

To assure the sample to be the same at each simulation session:

- The srand() function was fed by the same number which is 1.
- Calculations of all random variables were done by the same order and the same sequence, so that the results of the srand() function were all the same either in randomness or probabilities.
- The members of this sample were dropped (UEs tried to connect the cellular network) across cells with the same constant rate.
- Dropping users was done across the first seven cells (Node Bs), because Node B 0 was the main. Doing so made the handover calculations more realistic. There were handovers entering the main Node B 0 and handovers leaving out. While dropping across the first Node B only would produce incorrect values. This complied with our first guideline.

3.3.4 Mobility

At the beginning of each simulation session, UEs were given random initial velocities (speeds and directions). These velocities were kept constant during the whole session.

This was done for three reasons:

- Simulation was done to imitate real life where mostly everything is keep moving.
- Keeping velocities constants avoided us a lot of unnecessary statistical complications in deciding how would each user change the assigned velocity, when, where ... and so on. This agreed with our two guidelines.
- Keeping velocities constants helped keeping focus on the important issues of the search, which agreed with the first guideline.

The speed distributions suggested in [22] were adopted here.

Table 3.2 Speed distributions

Speed (Kmph)	3	15	20	40	60	80	100	120
Speed (m/s)	5/6	25/6	50/9	100/9	50/3	200/9	250/9	100/3
Probability	5%	15%	15%	15%	15%	15%	15%	5%

3.3.5 Doppler Effect

UE with node B: This is the case of Doppler effect generated by a mobile UE with a Node B. The effect of two mobile UEs on each other is not of our interest, since they are not effecting the download transmission, so they do not affect the capacity or coverage. But anyway, in case of arguing about its effect on the upload, the controlling signals and requesting data, it is much smaller than our studied case.

If we assume that highest allowed speed for vehicles is 120 kph = 33.333 m/s,

Then, Doppler effect for this extreme case

$$f_c = 2 \times 10^9 \text{ Hz}$$

$$\lambda = 3 \times 10^8 / f_c = 0.15 \text{ m}$$

$$f_{\text{Doppler}} = 33.333 / 0.15 = 222.222 \text{ Hz}$$

Extreme case for angle 0° and 180°

$$f = f_c + f_{\text{Doppler}}$$

$$\Rightarrow f_1 = 2000000222 \text{ Hz}$$

$$\Rightarrow f_2 = 1999999778 \text{ Hz}$$

$$\Rightarrow \lambda_1 = 0.1499999834 \text{ m}$$

$$\Rightarrow \lambda_2 = 0.1500000167 \text{ m}$$

$$\Rightarrow \text{Denominator for extreme case when } d=1 \text{ is } 157.9136704$$

$$\Rightarrow P_{r1} = 3.562072074 \text{ mW}$$

$$\Rightarrow P_{r2} = 3.562073656 \text{ mW}$$

\Rightarrow **Doppler effect can be ignored totally**

Case 2 (UE with another UE):

Doppler for two moving UEs

- ⇒ EXTREME case is double speed
- ⇒ double f_{Doppler}
- ⇒ f_{total} is much less than double **while** P_t has been reduced from 25 Watt to 0.125 Watt which is $1/200$
- ⇒ Also **Doppler effect can be ignored totally**

Note here that d is always greater than 1 because the transmitters are located at towers or high buildings while users are away from them.

3.3.6 Services

The simulation was done on cells (Node Bs) of 6 Mbps. This band was split between two services [22]:

- Web Browsing with average Tx rate = 64 Kbps
- FTP with average Tx = 384 Kbps

The two average Tx rates were selected in order to guarantee a good Quality of Service (QoS) for the two considered services.

Another assumption that has been done to guarantee a good QoS was restricting the cell (Node B) to a fixed number of users according to the Service Active Factor (SAF) that can take in maximum the 6 Mbps only. As it is known for CDMA systems their ability to add too many users at expense of quality of delivered signal, and as a result at expense of systems' range.

To study the effect of varying the SAF, for each service, a corresponding number of users were dropped according to SAF. In some simulations the FTP users' SAF was 40% of the total users. In other cases, the FTP users' SAF was 50% of the total users.

3.3.7 Simulation Phases

Each simulation session passed orderly through two phases, initialization phase and simulation phase.

3.3.7.1 Initialize Phase

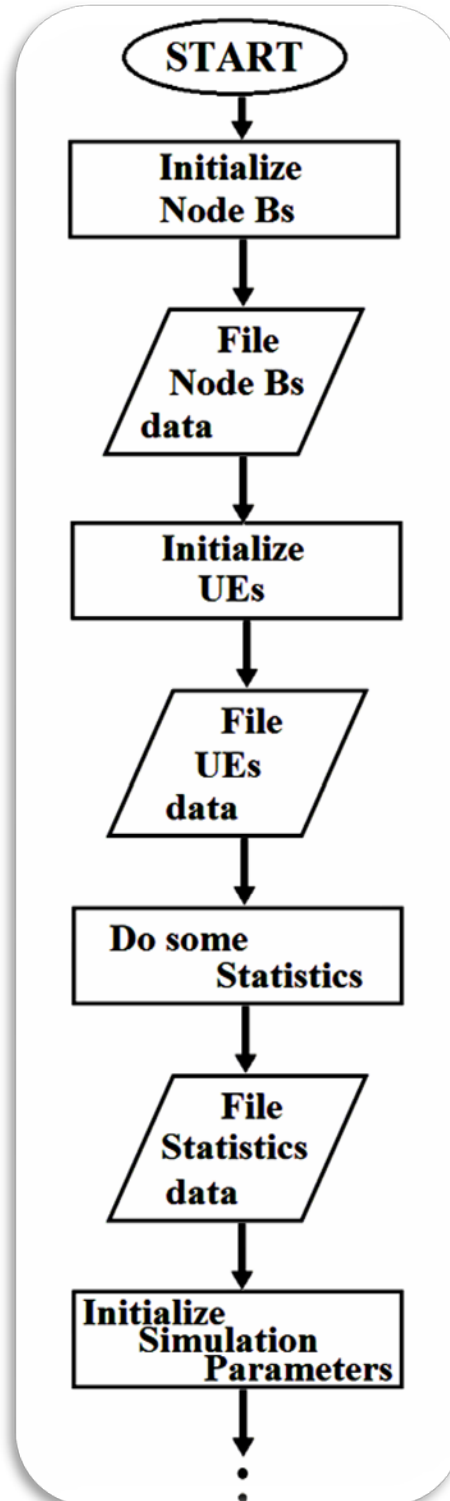

Figure 3.2 Initialization phase

In the initialization phase, the program calculates and assigns to each Node B:

- Identity number.
- Maximum load per Node B, 6 Mbps
- The coordinates and the borders.
- The power transmitted.
- Adjacent interfering Node Bs.

- The Service Activity Factor (SAF). Since two services are supported: Web Browsing 64 Kbps and FTP 384 Kbps, then for each service the number of users to be dropped in the simulation session were calculated according to

$$\text{Max number of WEB users} = (6000 * 0.6) / 64 = 56 \text{ users}$$

$$\text{Max number of FTP users} = (6000 * 0.4) / 384 = 6 \text{ users}$$

- All counters are set to zeros.

Then the program calculates and assigns to each UE:

- Identity number
- Coordinates and Node B to associate with.
- Power.
- Velocity.
- Type either web browsing or FTP.
- Duration.
- Interference from adjacent Node Bs.
- Handover candidates.
- Status
- Location in connected Node B.

3.3.7.2 Simulate Phase

The simulation phase starts after establishing the network in the initialization phase, these are the steps:

- The fresh UE tried to connect to the cell.
- All parameters were updated.
- Handover checked every 0.1 second.
- Parameters associated with handover were updated.
- All connected UEs were repositioned according to their velocities every 0.1 second.
- All parameters were updated according to the new positions.

3.3.8 Checking Results

The program had adopted many ways of checking results to ensure the correctness and accuracy of the results. Checking results was done through the entire program at different levels.

One way was the check done by the computer on the received signals from the connected users. Each Node B calculated the signals from the connected users accumulatively. Then before incrementing time for next iteration, a separate function did the calculations by initiating summations of current connected users. The difference between the two methods is that the first accumulated signals by adding connected users and subtracting disconnected users across the entire simulation session, while the check function summed instantaneously connected users regardless of disconnected and handovered out users.

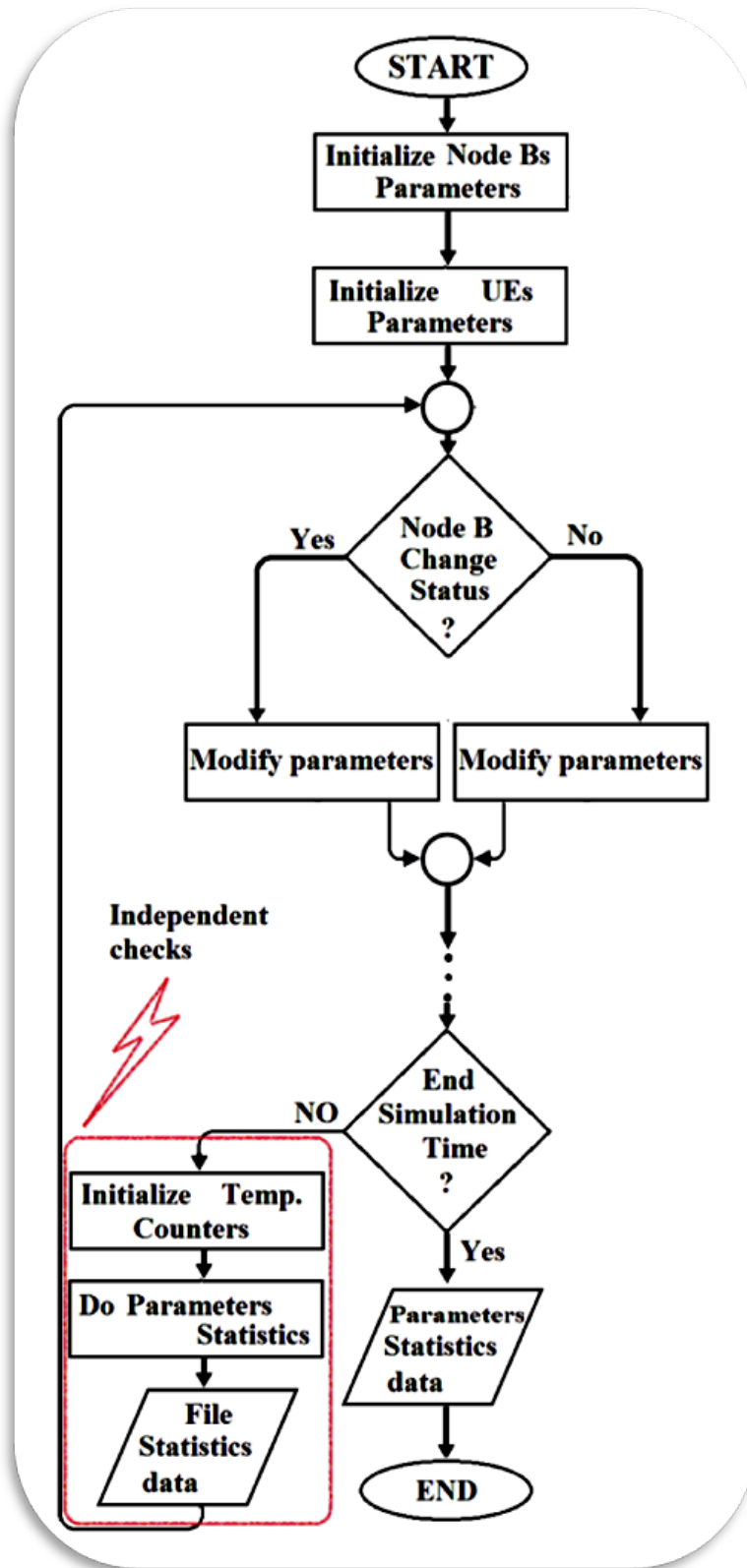

Figure 3.3 Checking Results functions

Another check function is designed to trace specific users. That is as the simulation session started, the program monitors a specific set of UEs. At the end of the session, the program wrote the whole journey of the UEs; turning on, connecting, moving, handovering, and disconnecting. This set of users is variable and can be changed by the designer.

Define an array to hold users' properties of interest
Choose the user to be traced
Initialize the array
Start writing the required properties to the array
Increment the array index with each time advance
Write the required properties to the array till the end time of the simulation
Write out the entire array

Figure 3.4 A pseudo code of checking results by tracing

A third check was done by examining the status of the whole network – Node Bs and UEs – before a process and after the process. Then the results could be compared manually as needed.

A fourth check was done by outputting the status of the network at the end of each iteration and before moving to the second iteration. Here also the results could be compared manually as needed.

A fifth check was done by preparing and outputting the Node Bs' and UEs' data for visualizing. This is a very important check, because with about 1500 UEs and more than 6000 files of iterations, it is very hard to check individual users manually.

Visualizing the network with its users helps checking in a few minutes. This visual check provides -in the worst case- a rough check. The difference between this and the other checks is that it involves only data, No comments and documentation like the other checks This is because it is designed to be read by the computer not human. See figure 3.5.

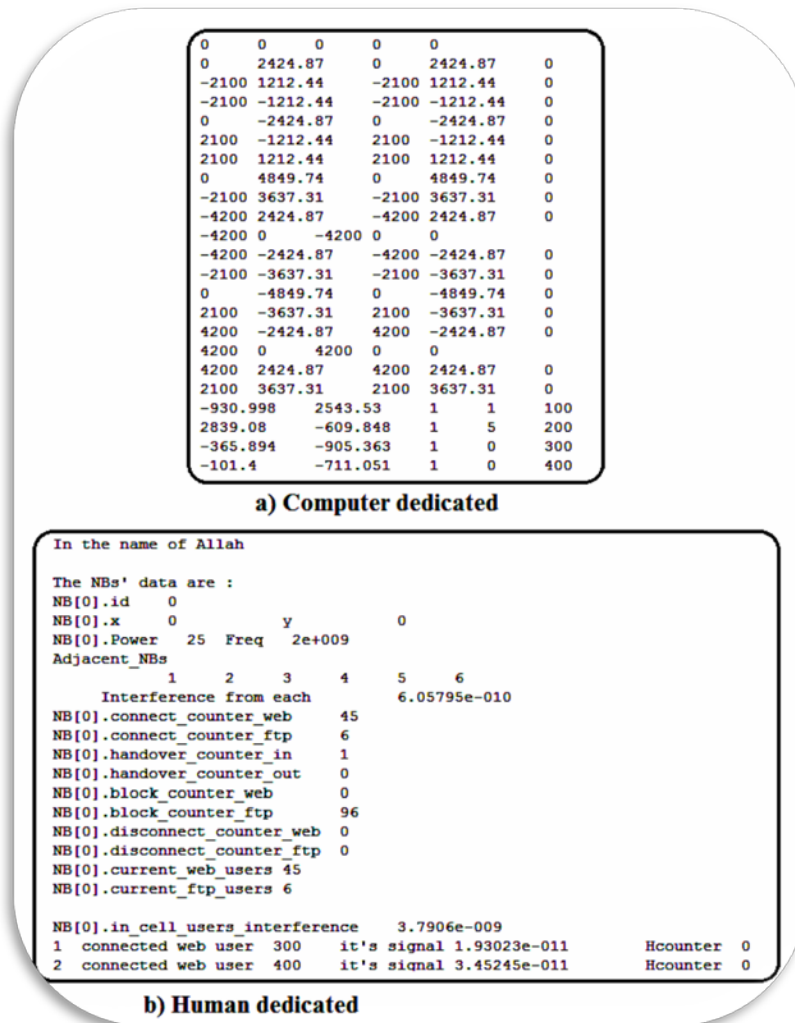

Figure 3.5 Difference between computer and human dedicated files

3.3.9 Filing

One of the most important features of the program is filing or documentation. That is every aspect of the network either constant or variable was documented and written in files. The importance of this strategy comes from the fact that during simulation session some figures or numbers pass quickly that can not be recognized. But filing these make it easier to check, compare and detect unusual or strange figures and numbers.

Number of generated files that contain outputs and checking results is 8,409 files. The occupied memory by these files is 1.26 GB.

3.4 Cell Splitting

The cellular system is studied after cell splitting is shown in figure 3.6. The Node Bs' range of coverage was reduced to half the original, thus the transmitted power by the new node B was modified to accommodate the new situation.

As proved in chapter 2 section 6, the power was reduced by a factor of $(\frac{1}{16})$.

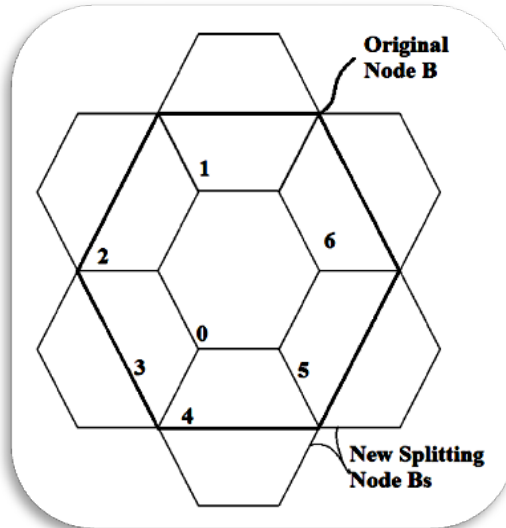

Figure 3.6 Performed splitting

Another parameter that had been modified was handover limit. This is logical as for a user with speed of 80 kmph for example, the distance travelled in 10 seconds is 222.2 m. This distance compared to 1400 m –the radius of the original Node B- is about 15%, while the same distance compared to 700 m –the radius of the splitted Node B - is about 31%. This means that if we used the same handover time limit of 10 seconds, it would force us to allow interference from adjacent node Bs deep to 30% which in turn reduces the capacity.

To keep the interfered area small while allowing soft handover, the handover time limit must be reduced. This reduction can be done either explicitly or by adding extra points to high speed UEs. The second scheme was adopted.

To ensure not modifying the results by changing the UEs random sample, the program started as usual, and a splitting function was added to perform splitting the Node Bs.

3.5 Sectoring

The adopted form is the 120° , as shown in figure 3.7.

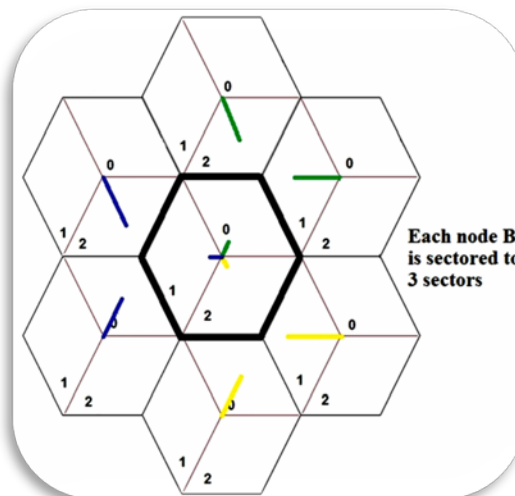

Figure 3.7 Performed sectoring

3.6 Radiation Exposure Calculations

An important factor in choosing the appropriate technique – as mentioned in chapter 2 - is the radiation exposure.

- For the original case:

Node B is transmitting a power of $P_{\text{Node B Original}}$ and

The in cell users interference at the center of the area covered by node B is $(P_{\text{ru}}=62*P_{\text{User Original}})$.

That is a person at the center of the node B is exposed to

$$I_{\text{original}} = P_{\text{Node B Original}} + 62*P_{\text{User Original}}$$

- For splitting case:

Node B is transmitting a power of $(P_{\text{m}}=\frac{P_{\text{Node B Original}}}{16})$ and

The in cell users interference at the center of the area covered by node B is $(P_{\text{ru}}=62*\frac{P_{\text{User Original}}}{16})$.

That is a person at the center of the node B is exposed to

$$\frac{P_{\text{Node B Original}}}{16} + 62*\frac{P_{\text{User Original}}}{16} = \frac{I_{\text{original}}}{16}$$

- For sectoring case:

Node B is transmitting a power of $(P_{\text{m}}=P_{\text{Node B Original}})$, and

Assuming fully utilized Node B with its three sectors →

The in cell users interference at the center of the area covered by node B is

$$(P_{\text{ru}}=62*P_{\text{User Original}}*3)$$

That is a person at the center of the cell is exposed to

$$P_{\text{Node B Original}} + 62*P_{\text{User Original}}*3 = I_{\text{original}} + 124* P_{\text{User Original}}$$

3.7 Algorithm

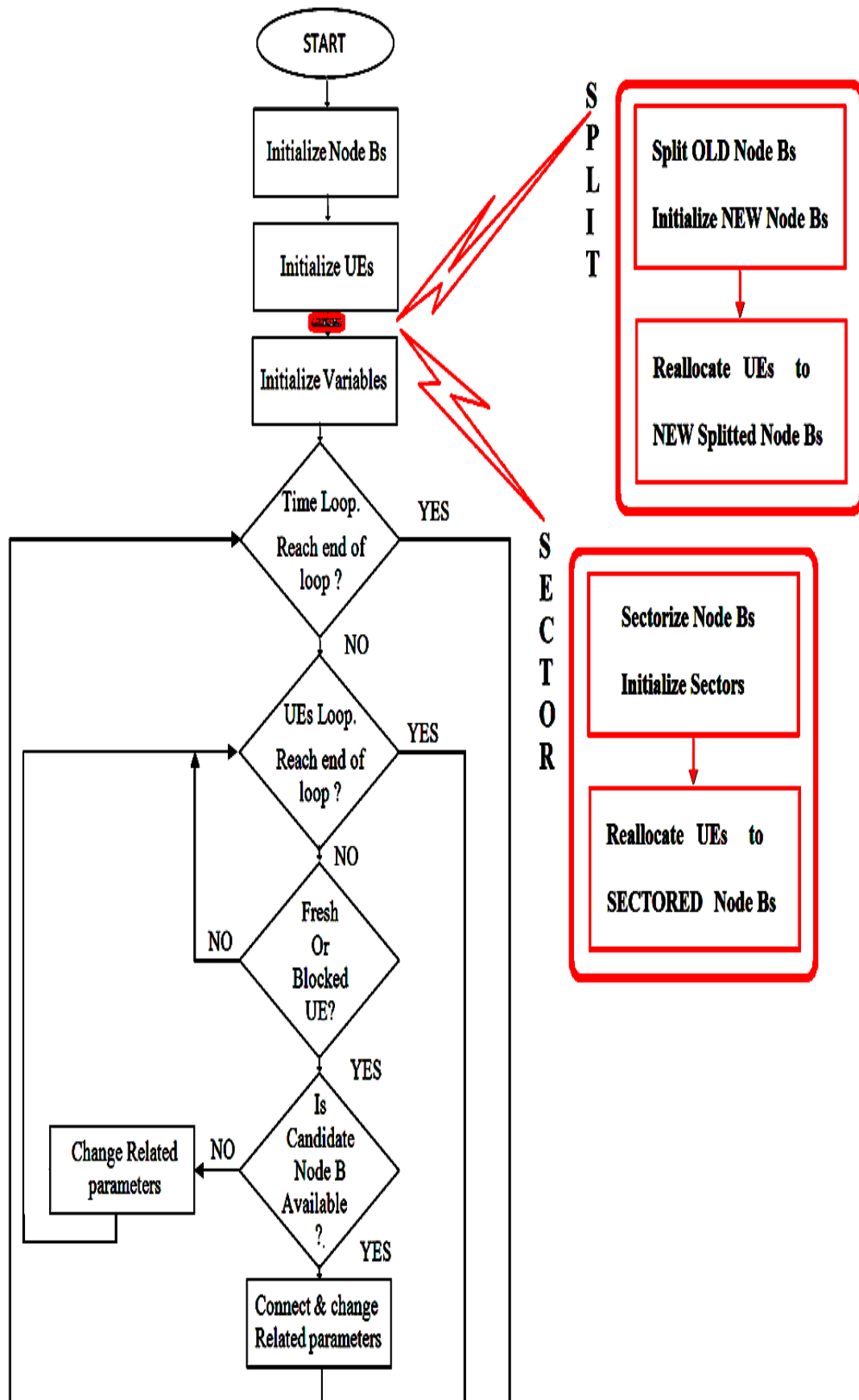
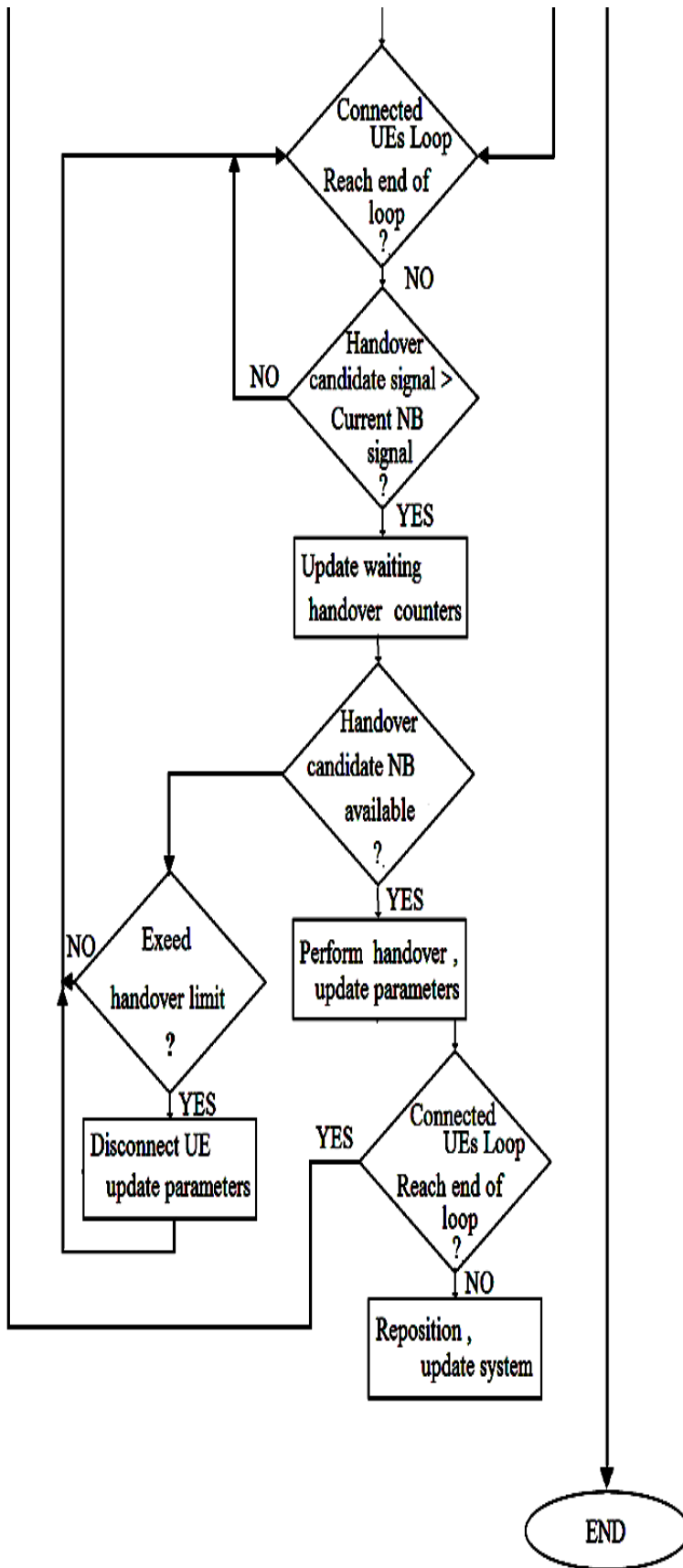

Figure 3.8 Program algorithm



Continue of Figure 3.8 program algorithm

3.8 Software

Simulating and debugging the cellular system was done by the Microsoft Visual C++ 2008 Express Edition.

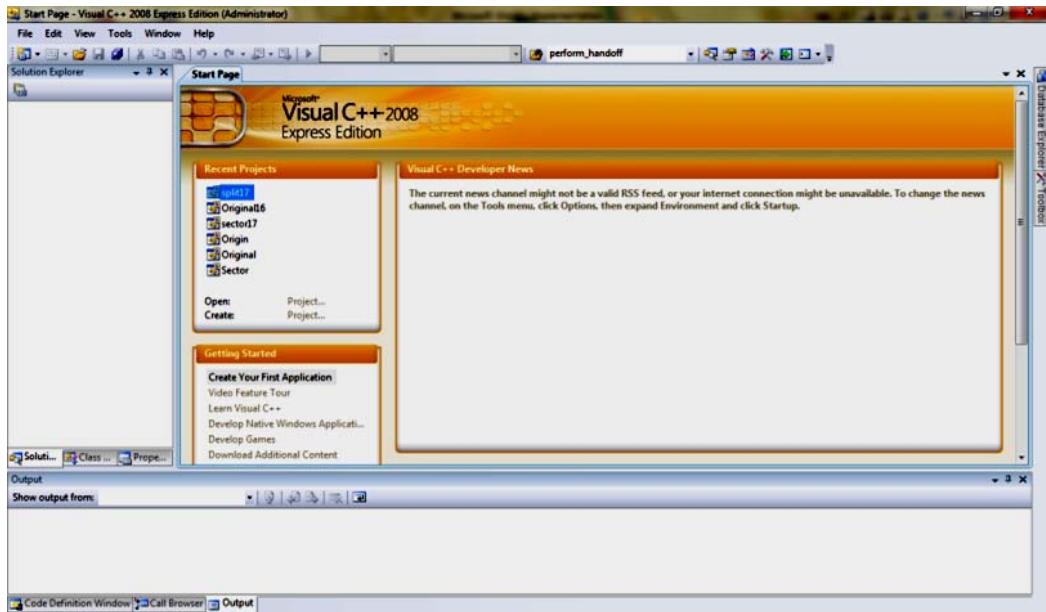

Figure 3.9 Microsoft Visual C++ 2008 Express Edition starting page

There were some properties that made this choice reasonable:

- Ease of use.
- Recent software
- The most important factor is that the software is FREE and fully functional.

Visualizing the tons of output files was done by another software. This software is Matlab. The required work was programmed as .m files.

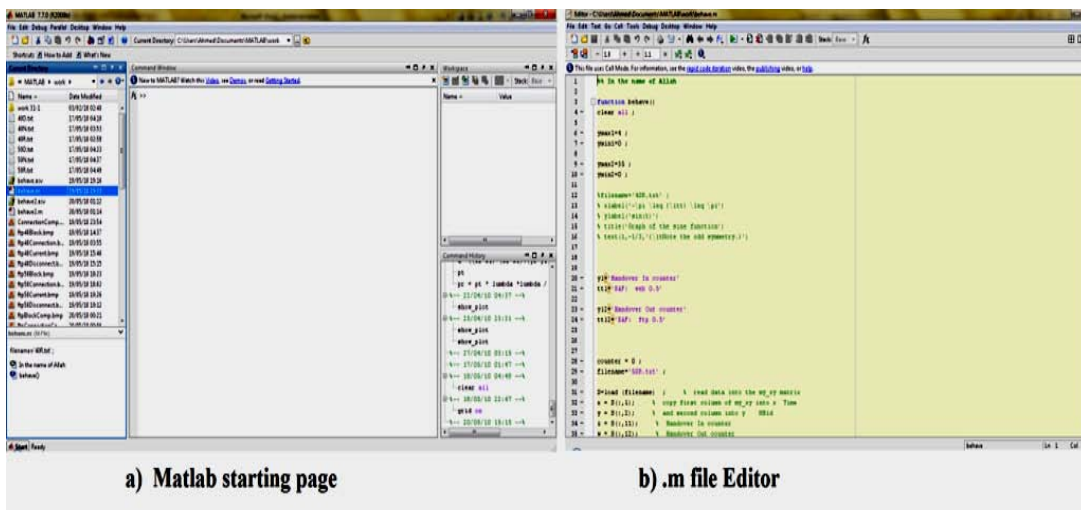

Figure 3.10 Visualization software

3.9 Assumptions and Limitations

To summarize the assumptions made and the limitations, which were stated throughout the chapter:

- The simulation platform is a network management system level simulation. It is a dynamic system simulation.
- Node B of interest is node B0 for original 3.5G cellular network. Its first and second tiers are calculated also.
- When applying cell splitting - to have the same area of the original cell - the node B of interest is node B0 and the summation of the surrounding node Bs divided by 2.
- When applying sectoring, the node B of interest is node B0.
- To simplify matters, an n of order 4 was used to estimate power. “These assumptions are reasonable if all the UEs have similar average radio conditions and similar capabilities. In this situation and due to the fact that HSDPA shares the physical channel among all the users, the available HSDPA bandwidth (and HSDPA resources) would be shared equally among all the users” [7].
- The same random sample of users was used when studying the parameters’ effects.
- Each user has a Rake receiver of 6 fingers.
- Mobility was assured by giving each user a random constant velocity (random speed and random direction). It is not variable as real life, but it is more realistic than a fixed 3 kmph for all users as [8].
- All connected UEs are repositioned according to their velocities every 0.1 second.
- Handover is checked every 0.1 second.
- As the speed of the user increases, the limiting time for handover decreases.
- Doppler Effect was eliminated.
- Services are Web Browsing with a transmission rate 64 Kbps and FTP with a transmission rate 384 Kbps.
- Each node B can accept a predefined number of users to assure a perfect QoS.
- Originally, each node B works on “missed calls cleared” as real life. But when varying the redial mode, it works as the new given parameters.
- The adopted sectoring is the 120°.

Chapter 4 Results

This chapter contains the results obtained during several simulation sessions, and the analysis of these results. Sometimes –like comparing combinations of splitted cells-, the results are put to explain the later choice, and they are not the target in themselves.

At the beginning of each simulation session some parameters were modified and stated, then the cellular network was studied for the following parameters:

- **Connect counter:** This is the number of UEs that managed to connect to a Node B. The user is using either web browsing or FTP service. This counter accumulates from the beginning of the session to the end.
- **Block counter:** This is the number of UEs that failed to connect to any Node B. This counter accumulates from the beginning of the session to the end.
- **Disconnect counter:** This is the number of UEs that were cut or dropped out of connection after establishing one. This counter accumulates from the beginning of the session to the end.
- **Current web users:** This is the number of web users currently connected to the Node B. This number indicates the instantaneous number of web users connected currently and in all means does not exceed the maximum number allowed.
- **Current FTP users:** This is the number of FTP users currently connected to the Node B. This number indicates the instantaneous number of FTP users connected currently and in all means does not exceed the maximum number allowed.
- **Handover counter in:** This is the number of UEs either web or FTP user who managed to perform a handover entering the specified Node B. This counter accumulates from the beginning of the session to the end.
- **Handover counter out:** This is the number of UEs either web or FTP user who managed to perform a handover leaving the specified Node B. This counter accumulates from the beginning of the session to the end.
- **Repeat redial:** the users failed to connect, were redialing again directly without waiting periods.
- **Delayed repeat:** the system allowed blocked users to try connecting after 30 iterations that is after 3 seconds.
- **No repeat:** the blocked users were dumped, and were not able to redial again.
- **Ratios** can be calculated from these totals. And since the random sample of users is the same for all simulation sessions, then the readings of the counters can be used interchangeably with ratios. Using the same random sample of users has in fact normalized the results.

- **Only results of varying the redial mode will be shown in details** to show how the work was done, while other results will be summarized here and can be seen in detail at the appendix.
- **To calculate the totals:**
 1. The connected and blocked users form the total users in the node B area. The disconnected users are not counted. This is to avoid calculating a user twice. The disconnected user was a connected one. Then, it was disconnected.
 2. The connected users form the total for handovered and disconnected users, since they must be connected first to handover or to be disconnected.

4.1 Varying the Redial mode for a system with web browsing Service Activity Factor 60% and FTP SAF 40%.

The simulation was done three times. The redial service varied each simulation session, Repeat, Delayed repeat and No repeat.

The results are visualized by matlab since they are tons of files for hundreds of users! This visualization makes it easier to compare than pure numbers.

4.1.1 Results

Table 4.1 Results of varying the redial modes with web SAF 60% and FTP SAF 40%

Counter of	Mode	Results Web SAF60% FTP SAF40%	% Compared to Repeat	Total =	Total Users	% Compared to total
Connected Users	No Repeat	148	98.67	Connected + Blocked	197	75.13
	Delayed	149	99.33		1754	8.49
	Repeat	150	-		46464	0.32
Blocked Users	No Repeat	49	0.11	Connected + Blocked	197	24.87
	Delayed	1605	3.47		1754	91.51
	Repeat	46314	-		46464	99.68
Disconnected Users	No Repeat	44	58.67	Connected	148	29.73
	Delayed	54	72		149	36.24
	Repeat	75	-		150	50
Handover	No Repeat	55	323.53	Connected	148	37.16
	Delayed	38	223.53		149	25.50
	Repeat	17	-		150	11.33

4.1.2 Notes About Results

1. Delayed redial mode introduced a significant improvement for the performance of the whole system, such that it increased the connection ratio, decreased blocked and disconnected ratios and increased handovers.

2. Delayed Redial mode has accomplished three main objectives:
 - Reduced the amount of work done by the whole system.
 - Reserved the given spectrum, since any initiating for a connection requires paging and dedicated channels.
 - Reduced amount of energy and power in air.
3. No repeat mode improved the performance further.
4. No Repeat mode has the property of not fully utilizing the Node B capacity.
5. No Repeat mode increases the number of handover. This is because of two reasons:
 - Node B is seldom goes to full utilization or full capacity.
 - Less competition on free codes, because blocked users are removed from redialing.

4.2 Varying Web browsing Service Activity Factor to 50% and FTP SAF to 50%

4.2.1 Tabular Results

Table 4.2 Results of varying the redial modes with web SAF 50% and FTP SAF 50%

Counter of	Mode	Results Web SAF50% FTP SAF50%	% Compared to Repeat	Total =	Total Users	% Compared to total
Connected Users	No Repeat	119	100.85	Connected + Blocked	192	61.98
	Delayed	116	98.31		2648	4.38
	Repeat	118	-		74048	0.16
Blocked Users	No Repeat	73	0.10	Connected + Blocked	192	38.02
	Delayed	2532	3.42		2648	95.62
	Repeat	73930	-		74048	99.84
Disconnected Users	No Repeat	40	59.70	Connected	119	33.61
	Delayed	50	74.63		116	43.10
	Repeat	67	-		118	56.78
Handover	No Repeat	33	825	Connected	119	27.73
	Delayed	19	475		116	16.38
	Repeat	4	-		118	3.39

4.2.2 Varying SAF Comparisons

Table 4.3 Comparing results of varying web SAF from 50% to 60% and FTP SAF from 50% to 40%.

Counter of	Mode	% Compared to Repeat. Web SAF 0.5	% Compared to Repeat. Web SAF 0.6	% Compared to Total. Web SAF 0.5	% Compared to Total. Web SAF 0.6
Connected Users'	No Repeat	100.85	98.67	61.98	75.13
	Delayed	98.31	99.33	4.38	8.49
	Repeat	-	-	0.16	0.32
Blocked Users'	No Repeat	0.10	0.11	38.02	24.87
	Delayed	3.42	3.47	95.62	91.51
	Repeat	-	-	99.84	99.68
Disconnected Users'	No Repeat	59.70	58.67	33.61	29.73
	Delayed	74.63	72	43.10	36.24
	Repeat	-	-	56.78	50
Handover	No Repeat	825	323.53	27.73	37.16
	Delayed	475	223.53	16.38	25.50
	Repeat	-	-	3.39	11.33

4.2.3 Results Analysis

- When varying web SAF from 60% to 50% the blocked users on repeat mode increases rapidly from **46464** to **74048**! This results because of two reasons:
 - Decreasing the amount of the devoted transmission to web users by 16 users yields increasing the blocked users.
 - Each recently blocked user works as a block generator. That is each 0.1 second the blocked user increment the counter of blocked users by 1. This results in 10 counts each second. For the worst case of 210 seconds, this means 2100 counts for a single user.
- Varying web SAF from 50% to 60% improved the performance of the cellular network. This is shown by the increased connection ratio, decreased blocked and disconnected ratios and increased handovers.

4.3 Cell Splitting

Cell splitting is done with Web SAF 60% & allowed redial with no restrictions.

4.3.1 Splitting Tabular Results

Table 4.4 Results of cell splitting

Counter of users	Mode	Results	% of Original	Total =	Total Users	% of total users
Connected	Original	150	-	Connected	46464	0.32
	Splitted	290	193.33	+ Blocked	3108	9.33
Blocked	Original	46314	-	Connected	46464	99.68
	Splitted	2818	6.08	+ Blocked	3108	90.67
Disconnected	Original	75	-	Connected	150	50
	Splitted	52	69.33		290	17.93
Handovered	Original	17	-	Connected	150	11.33
	Splitted	255	1500		290	87.93
Max. concurrent	Original	62	-	original	62	100
	Splitted	88	141.94	4* original	248	35.48

4.3.2 Splitting Results Analysis

1. Splitted Node Bs combination never goes to full utilization of its capacity neither web users nor FTP users.
2. Number of connected users after splitting jumped to 193.33%. This jump is not the maximum limit. This is obvious if we noticed another two parameters:
 - No web user was blocked after splitting. And the total of blocked users is 6.08% of the original.
 - Instantaneous current web users never reach the full utilization of the splitted Node Bs combination.
3. Existence of some blocked and disconnected users does not contradict the fact of not going to full utilization. The combination of splitted Node Bs does not go to full utilization, but some individual splitted Node Bs do go.
4. Cell splitting has improved the performance of the cellular network. This is obvious from increasing the connection ratio, decreasing the blocking and disconnecting ratios and increasing the handovers.

4.4 Sectoring

Cell sectoring is done with Web SAF 60% & allowed redial with no restrictions.

4.4.1 Results

Table 4.5 Results of sectoring

Counter of users	Mode	Results	% of Original	Total =	Total Users	% of total users
Connected	Original	150	-	Connected	46464	0.32
	Sectored	273	182	+ Blocked	5561	4.91
Blocked	Original	46314	-	Connected	46464	99.68
	Sectored	5288	11.42	+ Blocked	5561	95.09
Disconnected	Original	75	-	Connected	150	50
	Sectored	39	52		273	14.29
Handovered	Original	17	-	Connected	150	11.33
	Sectored	84	494.12		273	30.77
Max. concurrent	Original	62	-	original	62	100
	Sectored	81	130.65	3* original	186	43.55

4.4.2 Comparing Cell Splitting and Sectoring

Table 4.6 Comparing cell splitting and sectoring

Counter of users	Splitted % of Original	Sectored % of Original	Splitted % of total users	Sectored % of total users
Connected	-	-		0.32
	193.33	182	9.33	4.91
Blocked	-	-		99.68
	6.08	11.42	90.67	95.09
Disconnected	-	-		50
	69.33	52	17.93	14.29
Handovered	-	-		11.33
	1500	494.12	87.93	30.77
Max. concurrent	-	-		100
	141.94	130.65	35.48	43.55

4.4.3 Results Analysis

1. In all disciplines, cell splitting performs much better than sectoring.
2. Random values from the three simulation sessions at the same time, which is at second 144.1 of simulation:

Node B is transmitting	25 Watt
Original: in-cell users' interference	5.50865e-010 Watt

Node B is transmitting	1.5625 Watt
Split: in-cell users' interference	1.15622e-013 Watt

Node B is transmitting	25 Watt	
In-cell users' interference Sector	0	5.50751e-010 Watt
	1	3.77651e-015 Watt
	2	1.15393e-013 Watt

3. Splitted network does not reach fully utilization of Node Bs. That is during the simulation session the current users did not become 4 times of the original network.
4. Sectored network reaches fully utilization of Node Bs. That is during the simulation session reaches triple current users of the original network.

Chapter 5 Conclusion and Future Work

As the number of users of the 3.5G cellular network increases, the quality of service degrades and the coverage area shrinks.

To overcome this obstacle, the 3.5G cellular network operator should limit the number of users to a fixed number according to the required quality of service.

Limiting the number of users leads to fully utilized node Bs. This appears as an increment of blocking and disconnecting rates and as a decrement of handovering.

To solve this problem, we used two approaches:

- The first is modifying the parameters of the cellular network such as the radial modes and the service activity factor.

Modifying the radial mode from no restriction at all to no radial at all increased the connected users to 75.13%, reduced the blocked users to 24.87% and the disconnected users to 29.73% of the original and increased handovered users to 37.16% of the original.

Modifying the service activity factor for web users from 50% to 60% - with no radial - increased the connected users by $\approx 13\%$, reduced the blocked users by $\approx 13\%$ and the disconnected users by $\approx 4\%$ and increased handovered users by $\approx 10\%$.

- The second is modifying the cellular network itself either by cell splitting or sectoring.

Cell splitting and sectoring –under the same conditions of SAF and allowed radial with no restrictions- reduced the blocked users ratio to 90.67% and 95.09% respectively and the disconnected users ratio to 17.93% and 14.29% respectively. In the meanwhile they increased connected users to 9.33% and 4.91% respectively and the handovered users to 87.93% and 30.77% respectively.

Cell splitting exposes the center of the area covered by a node B with less power interference than original and sectored cellular network.

Cell splitting proved to be the best choice to increase the capacity and coverage of the cellular network through simulation sessions more comfortably than sectoring and without reaching the new limits.

Sectoring may seem good in cost of hardware, since it is just a matter of using sectored antennas. But sectored cellular network goes full faster. Using more sectors needs higher precision tools and means higher exposure to the power interference at the center.

Sectoring may work fine as a short term solution of network congestion, but cell splitting is the long term solution.

This research focused on choosing the best technique for increasing capacity and coverage of a cellular system. Meanwhile it left some aspects for future researches such as how to determine the optimal delay time or the best service activity factor.

The simulation platform also reserves a place for future power control calculations. Some variables and initial data for power usage are kept as constants or assumed to be under control.

References

- 1 J. Sanchez and M. Thioune, *UMTS*, ISTE Ltd, 2007, Chapters 3&6.
- 2 “3G”, <http://en.wikipedia.org/wiki/3G>, accessed 1April 2010.
- 3 M. A. Abu-Rgheff, *Introduction to CDMA wireless communications*, Academic Press, 1st edition, 2007, Ch. 2 & 8.
- 4 “3G”, <http://www.mobilein.com/3G.htm>, accessed 1April 2010.
- 5 “Basics”, <http://www.ftpplanet.com/ftpresources/basics.htm>, accessed 15 September 2009.
- 6 TSG-RAN Working Group 1, “*Evaluation Methods for HSDPA*”, Tech. Rep. meeting #14.
- 7 J. L. P. Adán, “*Effect of multiple simultaneous HSDPA users on HSDPA end-user performance for non-real time services in one cell system*”. Master thesis, Helsinki University of Technology, 7 August 2006
- 8 M. Wrulich, “*System-Level Modeling and Optimization of MIMO HSDPA Networks*”, PhD thesis, Vienna University of Technology, November 20, 2009
- 9 R.M. Fujimoto, *Network Simulation*, Morgan & Claypool, 2007, Chapter 5.
- 10 R. Ganesh “*Effect of non uniform user traffic distributions on the performance of a CDMA cellular system*”, IEEE, 0-7803-3777-8/97, 1997.
- 11 L.t Aydin, E. Esteves and R. Padovani, “*Reverse Link Capacity and Coverage Improvement for CDMA Cellular Systems Using Polarization and Spatial Diversity*”, IEEE, 0-7803-7400-2/02, 2002.
- 12 I. Koo, “*Erlang Capacity of a CDMA System Using Optimized Sectoring*”, IEEE, 07803-7605-6/02, 2002.
- 13 B. H. Pathak, “*Effect of error concealment methods on UMTS radio network capacity and coverage planning*”, (IJCNS) International Journal of Computer and Network Security, Vol. 2, No. 2, February 2010.
- 14 M. A. Nasr, “*Outage Probability and Percentage of Cell Area for OFDMA Cellular Systems with Sectoring*”, IEEE, 0-7695-2835-X/07, 2007.
- 15 N. Marina “*Improving the system capacity of a cellular network with partial power equalization*”, IEEE, 1 – 4244 – 2482 – 5/08, 2008.
- 16 A. S. Chowdhury, “*Performance of UMTS Handover by Cell Sectorization Using Opnet Modeller*”, 2009.
- 17 J. Laiho and A. Wacker, *Radio Network Planning and Optimisation for UMTS*, John Wiley 2nd edition, 2006, Chapter 8.
- 18 A. N. Ince, *Modeling and simulation tools for emerging telecommunication networks*, Springer, 2006, Chapter 9.

- 19 T. Rappaport, *Wireless Communications, principles and practice*, Prentice-Hall, 2nd edition, 2002, Ch. 1, 2&3.
- 20 K. Tachikawa, *W-CDMA Mobile communications system*, John Wiley & Sons, Ltd, 2002, Chapter 2.
- 21 I. Poole, *Cellular communications Explained from basics to 3G*, Newnes Ltd, 1st edition, 2006, Ch. 1&2.
- 22 A. M. Mousa, “*4G Inter-working Cellular and WLAN Networks, Seamless Mechanisms and Enhanced Power Control*”, PhD thesis, National Technical University of Athens, 2004.
- 23 J. Korhonen, *Introduction to 3G mobile communications*, Artech House, Inc, 2nd edition. 2001. Ch. 1, 2 & 4.
- 24 A.D. Usman, “*Wireless Phones Electromagnetic Field Radiation Exposure Assessment*”, American J. of Engineering and Applied Sciences, No 2, vol 4, pp 771-774, 2009
- 25 N. Kumar¹ and G. Kumar, “*Biological Effects of Cell Tower Radiation on Human Body*”, ISMOT, conference paper presentation, 2009.
- 26 H. Buddendick, *An Introduction to Static 3G Network Simulations within ProMan*, AWE Communications GmbH, December 2005.

Appendix A

Environmental Instructions

تعليمات صادرة عن سلطة جودة البيئة لعام 2003م بشأن الوقاية من الإشعاع غير المؤين

رئيس سلطة جودة البيئة استنادا إلى قانون البيئة رقم 7 لسنة 1999 وبناء على ما تقدمت به اللجنة الوزارية المكلفة بإعداد اللائحة التنفيذية الخاصة بالوقاية من الإشعاع والتنسيق مع وزارة الاتصالات وتكنولوجيا المعلومات. تقرر ما يلي :

مادة (1)

يكون للكلمات والمصطلحات التالية المعاني المخصصة لها أدناه ما لم تدل القرينة على خلاف ذلك:
الإشعاع غير المؤين (Non – Ionizing Radiation (NIR): ويشمل كل إشعاعات وحقول الطيف الكهرومغناطيسي التي لا تملك الطاقة الكافية لتأين ذرات المادة ويتميز بطاقة فونونية تقل عن 12 إلكترون فولت وبطول موجي يزيد عن 100 نانومتر (nm) وتردد يقل عن 3×10^{15} هرتز⁽¹⁵⁾
الموجة الكهرومغناطيسية: Electromagnetic Wave هي موجة تنتشر في الفضاء بسرعة الضوء $C = 3 \times 10^8$ (m/s) وتتكون من حقل كهربائي وحقل مغناطيس متعامدان على بعضهما وعلى اتجاه الانتشار وكلاهما يتغير مع الزمن .

الطول الموجي Wave Length: يعبر الطول الموجي لموجة كهرومغناطيسية دورية عن المسافة بين أي نقطتين متتاليتين في اتجاه الانتشار ولهما نفس الطور وهو يتناسب عكسيا مع تردد (f) تلك الموجة. $C = \lambda f$
التردد Frequency: هو عدد الاهتزازات الجيبية التي تحدثها الموجة الكهرومغناطيسية في الثانية الواحدة ويقاس بالهرتز.

المدى الترددي Frequency Range: هو جزء من الطيف الترددي يبدأ بتردد وينتهي آخر يطبق خلاله معيار معين أو عدة معايير.

كثافة القدرة Power Density (S): هي القدرة الإشعاعية الساقطة على وحدة المساحات المتعامدة على اتجاه الإشعاع، وتعتبر مقياسا لمستوى الإشعاع في حال التعرض له. وتقاس بالواط لكل متر مربع.
القدرة Power: هي معدل بذل الشغل بالنسبة للزمن وتقاس بالواط ويفترض أن تكون القدرة الكهرومغناطيسية للإشعاع كافية حتى يتمكن من الوصول للهدف.

الهوائي Antenna: هو جهاز يقوم بتحويل الإشارات الكهربائية إلى موجات كهرومغناطيسية والعكس ويأخذ أشكالا متعددة وله متغيرات خاصة به مثل الكسب ونوعية الاستقطاب.

كسب الهوائي Antenna Gain: يمثل النسبة بين القدرة المطلوبة لهوائي مرجعي بدون فاقد إلى القدرة الداخلة إلى الهوائي الفعلي في اتجاه معين حتى يعطي الهوائيان نفس كثافة القدرة عند نفس المسافة ويقاس بالديسيبل أو dBi عند وجود هوائي نصف موجي وثنائي القطبية.

المحطة Station: هي مجموعة من أجهزة الإرسال والاستقبال والهوائيات تقوم بتغطية منطقة جغرافية معينة ضمن نطاق ترددي محدد للموجات الكهرومغناطيسية وذلك بغرض الاتصالات أو البث الإذاعي أو البث التلفزيوني.

التعرض Exposure: يقصد به تعرض الإنسان في أي مكان أو زمان لحقل كهربائي أو مغناطيسي أو كهرومغناطيسي خلاف تلك الحقول التي تنشأ في جسم الإنسان نتيجة التفاعلات الفسيولوجية أو الظواهر الطبيعية.
التعرض غير الخاضع للتحكم العامة: Uncontrolled Exposure هو تعرض العامة الكلي للحقول الكهربائية والمغناطيسية باستثناء التعرض المهني والطبي.

التعرض الخاضع للتحكم المهني: Controlled Exposure هو تعرض العاملين الكلي للحقول الكهربائية والمغناطيسية والكهرومغناطيسية أثناء أدائهم للعمل في مجال الإشعاع.

معدل الامتصاص النوعي Specific Absorption Rate (SAR): هي معدل الطاقة الإشعاعية الممتصة بواسطة أنسجة الجسم بالنسبة للزمن وتقاس بالواط لكل كيلوجرام وهي تتناسب طرديا مع مربع شدة الحقل الكهربائي في حالة الترددات الأعلى من 100 كيلوهرتز وتعتبر هذه الكمية المرجعية التي تبنى عليها إجراءات الوقاية من الإشعاع لإمكانية حدوث تأثيرات بيولوجية.

الامتصاص النوعي Specific Energy Absorption (SA): قيمة الطاقة الممتصة في وحدة الكتل للنسيج الحي معبرا عنها بالجول لكل كيلوجرام ويمثل الامتصاص النوعي التكامل الزمني لقيمة معدل الامتصاص النوعي.

عمق الاختراق Depth of Penetration: يقصد به عمق الاختراق للموجة الكهرومغناطيسية المستوية الساقطة على موصل جيد، الذي يؤدي إلى هبوط في شدة الحقل بمقدار 37% من القيمة الأصلية.

شدة الحقل الكهربائي (E): Electric Field Strength هو مقدار متجه الحقل الذي يمثل مقدار القوة (F) التي تؤثر على شحنة كهربية موجبة اختبارية (Q) عند نقطة ما مقسومة على قيمة تلك الشحنة ($E=F/Q$) وتقاس بالفولت لكل متر (V/m).

شدة الحقل المغناطيسي (H): Magnetic Field Strength هو مقدار متجه الحقل الذي يمثل مقدار كثافة الفيض المغناطيسي (B) مقسوما على معامل نفاذية الوسط وتقاس بالأمبير لكل متر (A/m).

كثافة الحقل المغناطيسي (B): Magnetic Flux Density هو مقدار متجه الحقل الذي يمثل مقدار القوة التي تؤثر على شحنة أو عدة شحنات متحركة وتقاس بالتسلا.

كثافة التيار: Current Density هو تدفق التيار خلال سطح ما وبالنسبة للموصل الخطي فان كثافة التيار هي ناتج قسمة شدة التيار المار على مساحة مقطع الموصل.

التيار المستحث: Induced Current هو التيار الكهربائي المتولد، بخاصية الحث الكهرومغناطيسي، داخل جسم الإنسان عند تعرضه للحقول الكهرومغناطيسية.

تيار التماس: Contact Current هو التيار الذي يسري في جسم الإنسان عند تلامسه مع أي جسم آخر له جهد كهربائي مختلف حيث أن الأجسام الموصلة المشحونة بالحقول الكهرومغناطيسية تسبب مرور تيارات كهربية في جسم الإنسان الذي يتلامس معها.

القيمة الفعالة: Root Mean Square (rms) هي القيمة الفعالة للموجة الكهرومغناطيسية الدورية وتحسب من الجذر التربيعي لمتوسط مربع الدالة الدورية (لفترة دورية واحدة) وهي تتناسب مع تأثيرات كهربية حرارية.

قيمة الذروة: Peak Value هي قيمة الذروة لمتغيرات الموجة الكهرومغناطيسية الدورية مثل شدة الحقل الكهربائي وشدة الحقل المغناطيسي.

الموجة النبضية: Pulsed Wave هي موجة كهرومغناطيسية تتواجد فقط لجزء من الوقت يسمى مدة النبضة حيث تنتشر سلسلة النبضات بتقطع فجائي بعد كل فترة نبضية.

الموجة المستوية: Plane Wave هي موجة كهرومغناطيسية يقع فيها متجهي الحقل الكهربائي والحقل المغناطيسي في مستوى واحد عمودي على اتجاه انتشار الموجة وتكون شدة الحقل المغناطيسي (مضروبة في معاوقة الفراغ) متساوية مع شدة الحقل الكهربائي وفقا للعلاقة $E = H \cdot Z$ حيث $Z = 377$ للفراغ، وتتواجد الموجات المستوية في المنطقة التي يكون فيها بعد أي نقطة عن الهوائي أكبر من طول الموجه الصادرة عن ذلك الهوائي.

التقييدات الأساسية: Basic Restrictions هي تقييدات، خاصة بالتعرض للحقول الكهربية والمغناطيسية والكهرومغناطيسية، تركز على التأثيرات الصحية المثبتة، وتبعاً للتردد فان كثافة التيار (J) ومعدل الامتصاص النوعي (SAR) وكثافة القدرة (S) تمثل الكميات الفيزيائية المستخدمة لتحديد تلك التقييدات ولذلك يحظر تجاوز هذه التقييدات حتى تنقضى التأثيرات الصحية السلبية.

المستويات المرجعية: Reference Levels هي مستويات مرجعية، خاصة بالتعرض للحقول الكهربية والمغناطيسية والكهرومغناطيسية، تتم مقارنتها بالقيم المقاسة حيث أن الامتثال لهذه المستويات يضمن الالتزام بالتقييدات الأساسية، أما إذا كانت القيم المقاسة أعلى من المستويات المرجعية فهذا لا يعني بالضرورة أنه تم تجاوز التقييدات الأساسية ولكن من الضروري في هذه الحالة عمل تحليلات إضافية لتقييم الالتزام بتلك التقييدات.

مادة (2)

يجب الالتزام بالشروط التالية في جميع محطات البث:

1. إنارة أبراج الهوائيات بحيث تكون في أعلى البرج.
2. عدم التسبب في إحداث أي تداخل مع محطات أخرى أو تشويش على خدمات أخرى.
3. عزل حقول الهوائيات عزلاً تاماً بحيث توفر عوامل السلامة للمارة والسكان.
4. وضع الإشارات التحذيرية المناسبة بشكل واضح تبيين المحيط المعزول.
5. تزويد المحطة بنظام مانع صواعق مناسب.
6. توفير نظام إنذار ضد الحريق وكذلك التجهيزات اللازمة للإطفاء والإسعافات الأولية.
7. عمل نظام تأريض للأبراج وللأجهزة حسب الأصول الفنية لأمن وسلامة العاملين.
8. عمل فحص دوري، مرتين سنوياً، للتأكد من فعالية إجراءات الأمان وتوثيق ذلك.
9. استعمال هوائي معياري معزول عند إجراء فحوصات أو تجارب على الأجهزة العاملة.
10. اتخاذ كافة الإجراءات وتوفير جميع المتطلبات اللازمة التي تكفل سلامة العاملين.
11. إجراء الفحوصات الطبية اللازمة للعاملين في تشغيل وصيانة أجهزة البث دورياً للتأكد من عدم إصابتهم بأي أضرار صحية نتيجة تعرضهم لمستويات إشعاعية غير مسموحة.
12. توفير كافة أجهزة القياس اللازمة لقياس كثافة القدرة وشدة المجال الكهربائي والمغناطيسي وبمواصفات تتفق مع التردد والقدرة المستخدمتين.
13. إجراء جميع القياسات المطلوبة شهرياً وتوثيقها.

مادة (3)

- أ. تهدف التقييدات الأساسية الخاصة بالتعرض الإشعاعي الغير مؤين، تبعاً للمدى الترددي، إلى ما يلي:
1. منع حدوث تأثيرات على وظائف الجهاز العصبي من جراء كثافة التيار في المدى الترددي من 1 هرتز إلى 10 ميغاهرتز
 2. منع حدوث كلا من التسخين الكامل للجسم والتسخين المفرط المتمركز على النسيج من جراء معدل الامتصاص النوعي في المدى الترددي من 100 كيلوهرتز إلى 10 جيغاهرتز.
 3. منع التسخين المفرط للنسيج سواء على سطح الجسم أو قريباً منه وذلك من جراء كثافة القدرة في المدى الترددي من 10 إلى 300 جيغاهرتز
- ب. يحظر تجاوز التقييدات الأساسية الواردة في الجدول رقم (1) والخاصة بالحقل الكهربائي والمغناطيس لمتغير مع الزمن للمدى الترددي حتى 10 جيغاهرتز لكلاً من التعرض الخاضع للتحكم والتعرض غير الخاضع للتحكم. جدول رقم (1) التقييدات الأساسية للحقول الكهربائي والمغناطيسية المتغيرة مع الزمن للترددات حتى 10 جيغاهرتز
- ج. يحظر تجاوز التقييدات الأساسية الواردة في الجدول رقم (2) والخاصة بكثافة القدرة للمدى الترددي من 10 إلى 300 جيغاهرتز لكل من التعرض الخاضع للتحكم والتعرض غير الخاضع للتحكم. جدول رقم (2) التقييدات الأساسية الخاصة بكثافة القدرة للمدى الترددي من 10 إلى 300 جيغاهرتز

مادة (4)

- أ. تم الحصول على المستويات المرجعية من التقييدات الأساسية وذلك بواسطة نماذج رياضية خاصة واستقراء (extrapolation) نتائج البحث المعملية عند ترددات محددة.
- ب. يجب عدم تجاوز المستويات المرجعية الواردة في الجدولين رقم (3) ورقم (4) والمبينه أيضاً في الشكلين رقم (1) ورقم (2) من الملحق الثاني والخاصة بالحقول الكهربائية والمغناطيسية المتغيرة مع الزمن لكل من التعرض الخاضع للتحكم والتعرض غير الخاضع للتحكم. جدول رقم (3) المستويات المرجعية للتعرض الخاضع للتحكم والخاصة بالحقول الكهربائية والمغناطيسية المتغيرة مع الزمن (القيم الفعالة) (المنتظمة). جدول رقم (4) المستويات المرجعية للتعرض غير الخاضع للتحكم والخاصة بالحقول الكهربائية والمغناطيسية المتغيرة مع الزمن (القيم الفعالة) (المنتظمة).
- ت. يجب عدم تجاوز المستويات المرجعية الواردة في الجدول رقم (5) والخاصة بتيار التماس المتغير مع الزمن من الأجسام الموصلة لكل من التعرض الخاضع للتحكم والتعرض غير الخاضع للتحكم. جدول رقم (5) المستويات المرجعية لتيارات التماس المتغيرة مع الزمن من الأجسام الموصلة
- ث. يجب عدم تجاوز المستويات المرجعية الواردة في الجدول رقم (6) والخاصة بالتيار المستحث في أي جزء من الجسم للمدى الترددي من 10 إلى 110 ميغاهرتز لكلاً من التعرض الخاضع للتحكم والتعرض غير الخاضع للتحكم. جدول رقم (6) المستويات المرجعية للتيار المستحث في أي جزء من الجسم للمدى الترددي من 10 إلى 110 ميغاهرتز

مادة (5)

يعمل بهذه التعليمات من تاريخ نشرها بالجريدة الرسمية .

صدر في مدينة غزة بتاريخ: 22/أكتوبر/2003م رئيس سلطة جودة البيئة د. يوسف أبو صفية

ديوان الفتوى و التشريع

http://www.dft.gov.ps/index.php?option=com_dataentry&pid=8&Itemid=27&des_id=544, accessed 1 April 2010.

Appendix B Simulation Parameters

Num of cells	19
Shape	Three sectored, hexagonal cells
Radius	1400m
Propagation model	$P_r = P_t \frac{G_r G_t \lambda^2}{(4\pi d)^2}$
Mobility	Low mobility + vehicular speeds
Services	Web browsing (64kbps, SAF=0.6) FTP (384kbps, SAF=0.4)
Traffic load per sector	6 Mbps

Appendix C

Simulation results

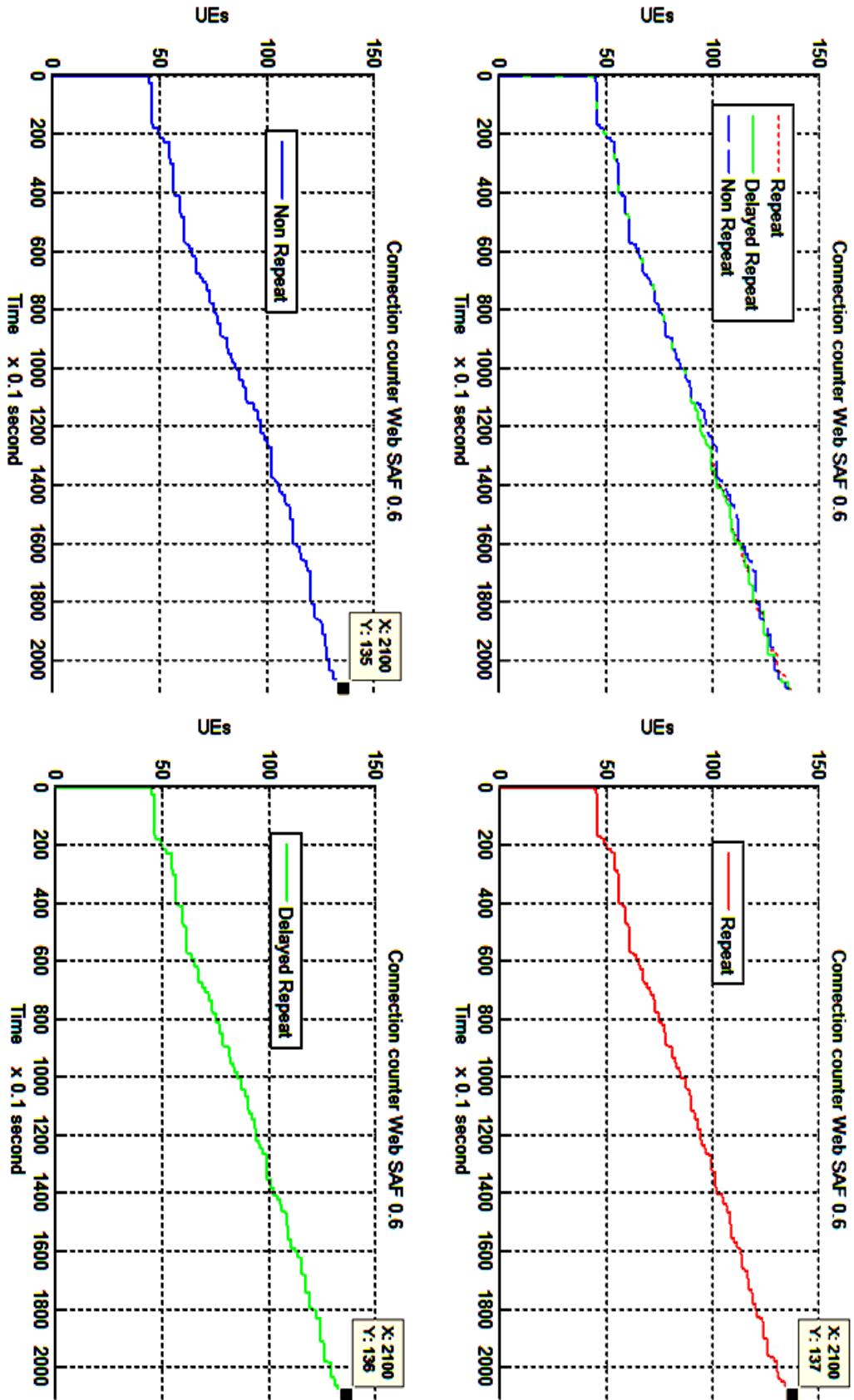

Figure C.1 Connection counter for Web users with SAF 60%

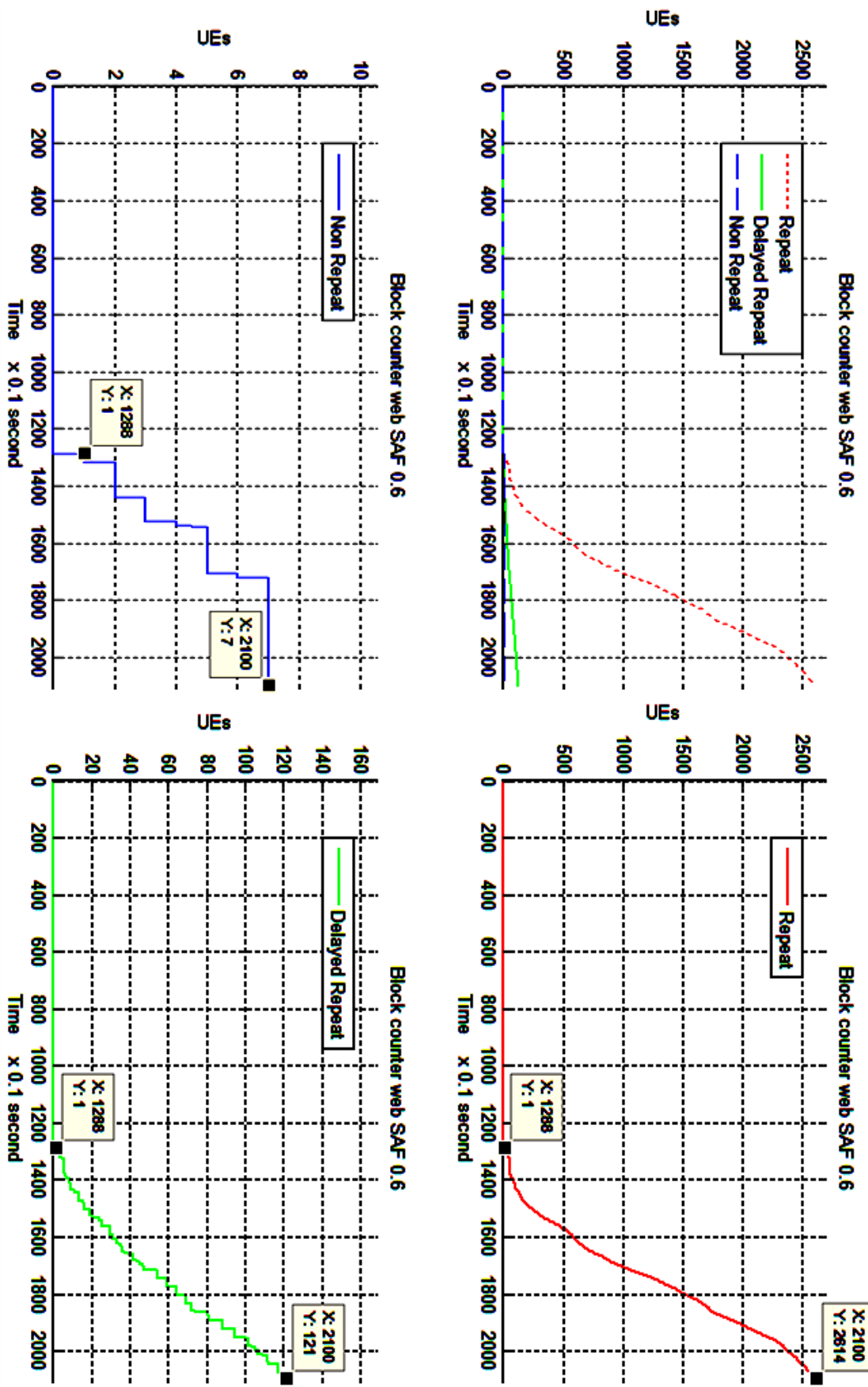

Figure C.2 Block counter for Web users with SAF 60%

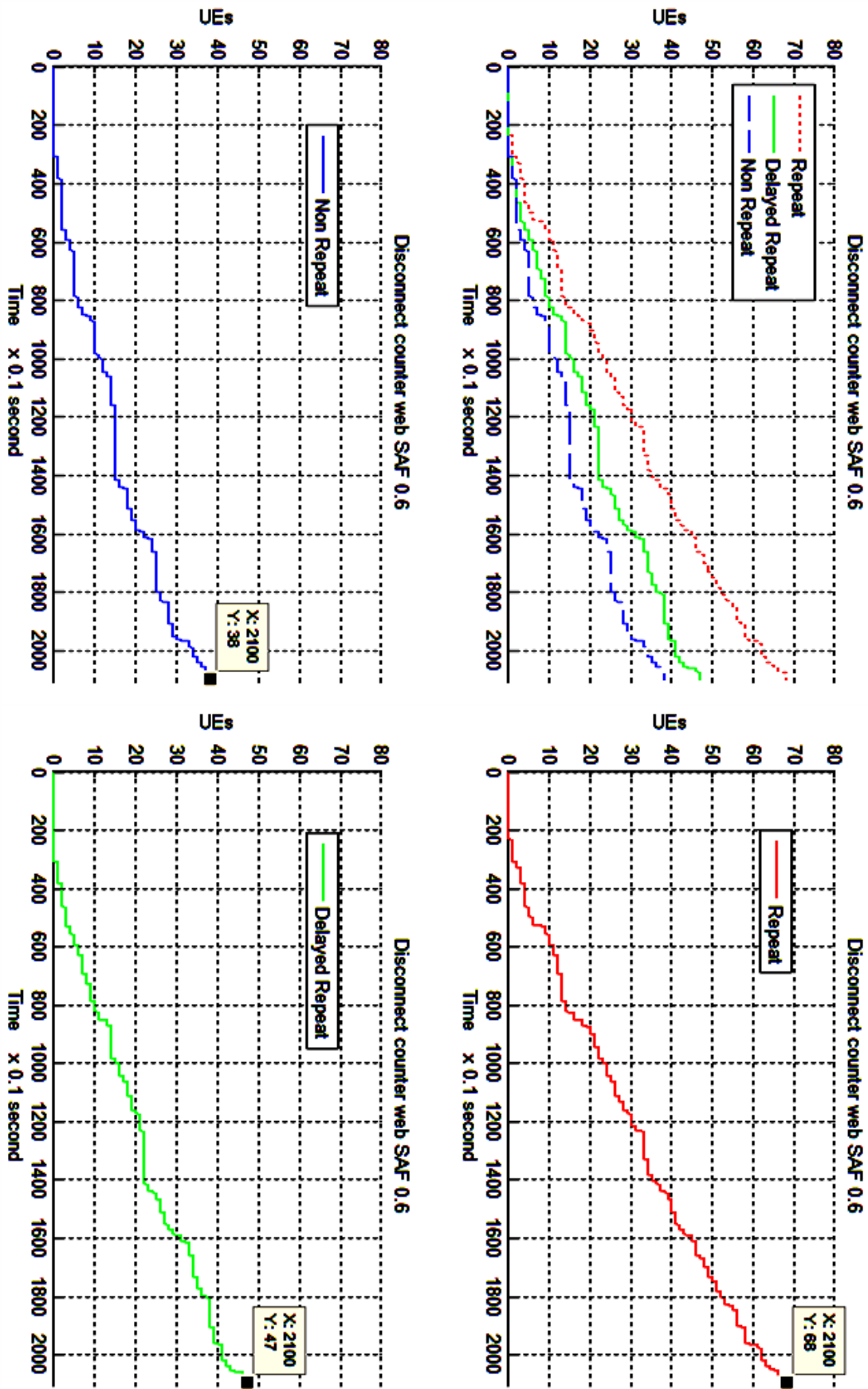

Figure C.3 Disconnect counter for Web users with SAF 60%

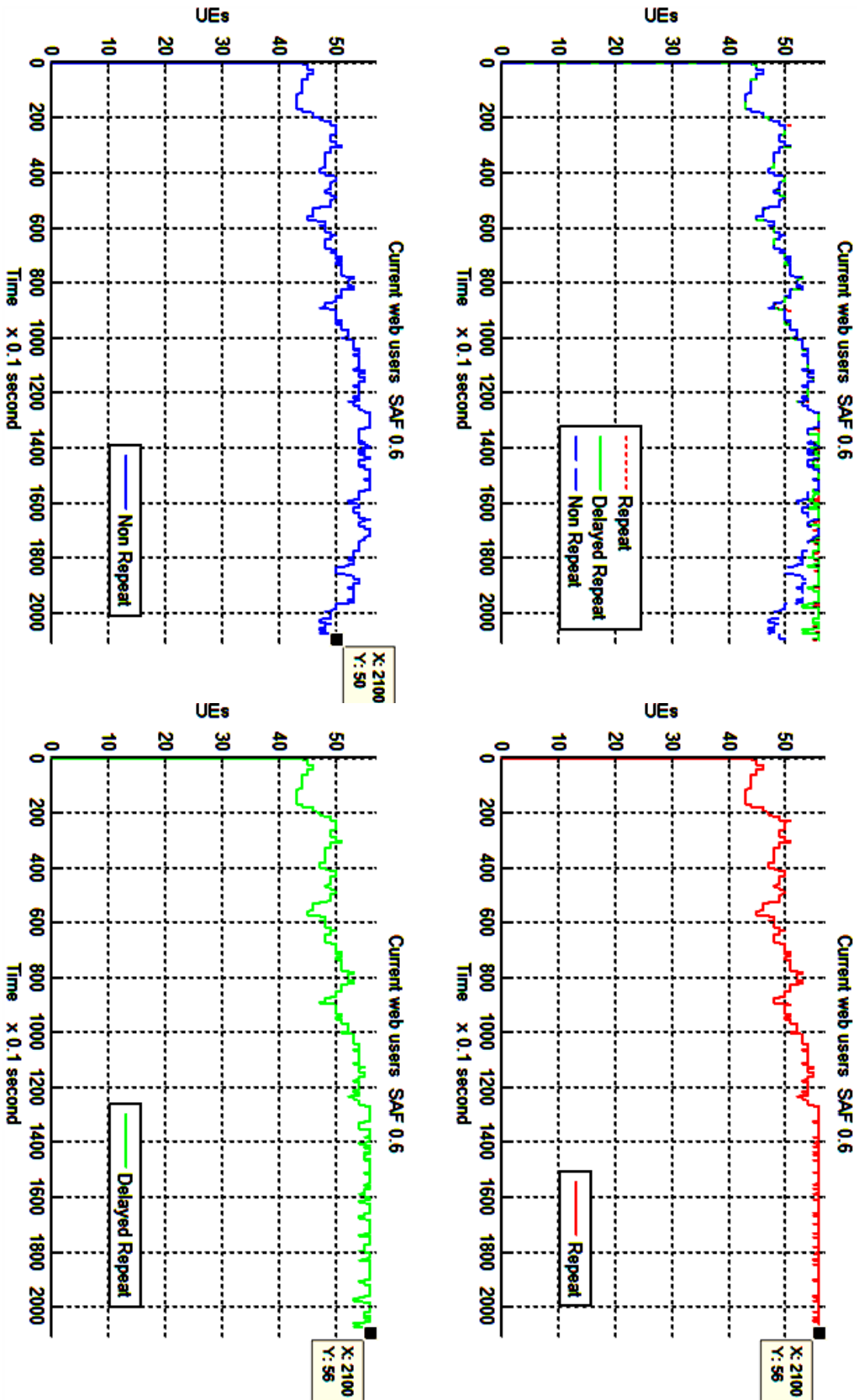

Figure C.4 Current Web users with SAF 60%

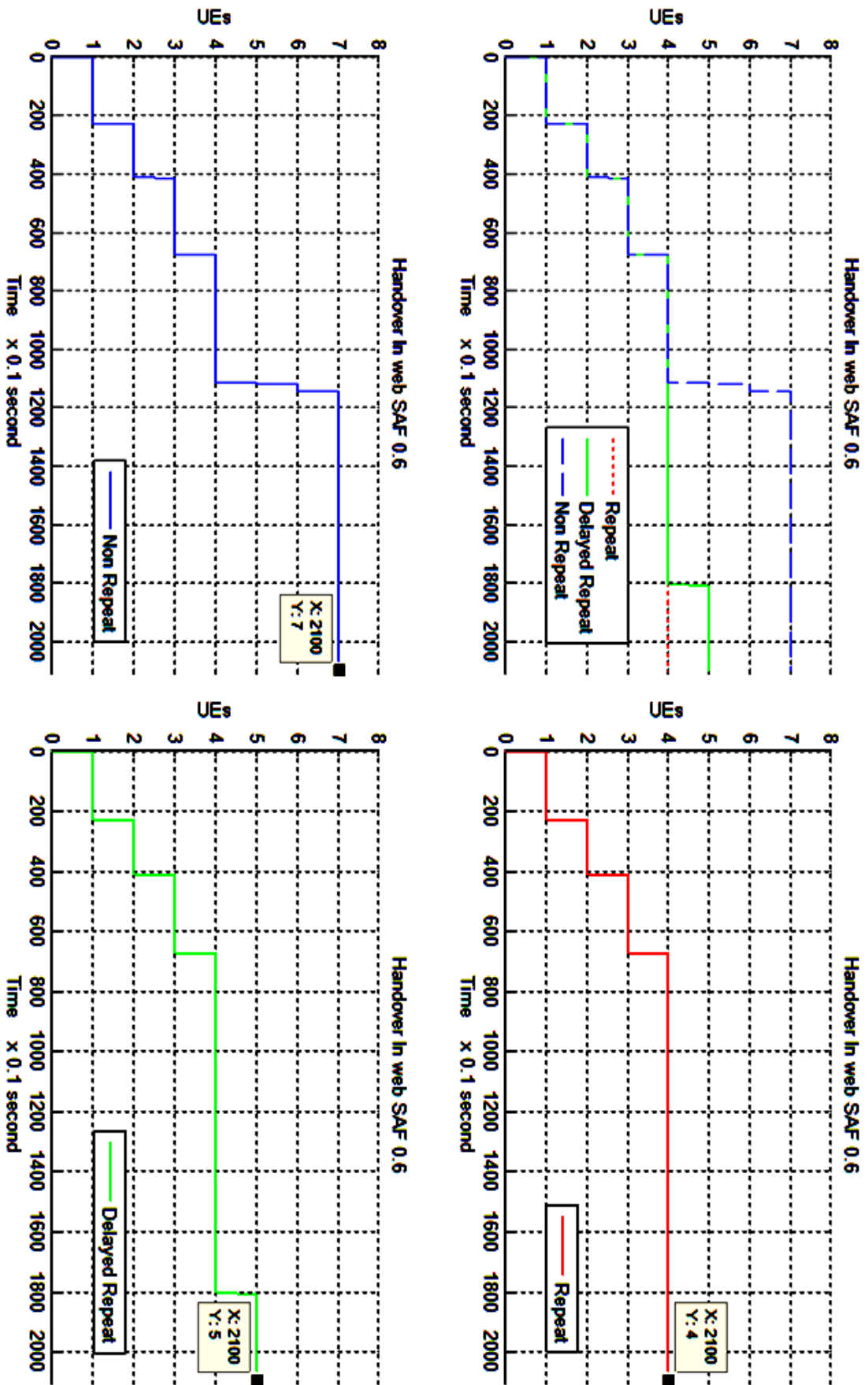

Figure C.5 Handover In counter when web SAF 60%

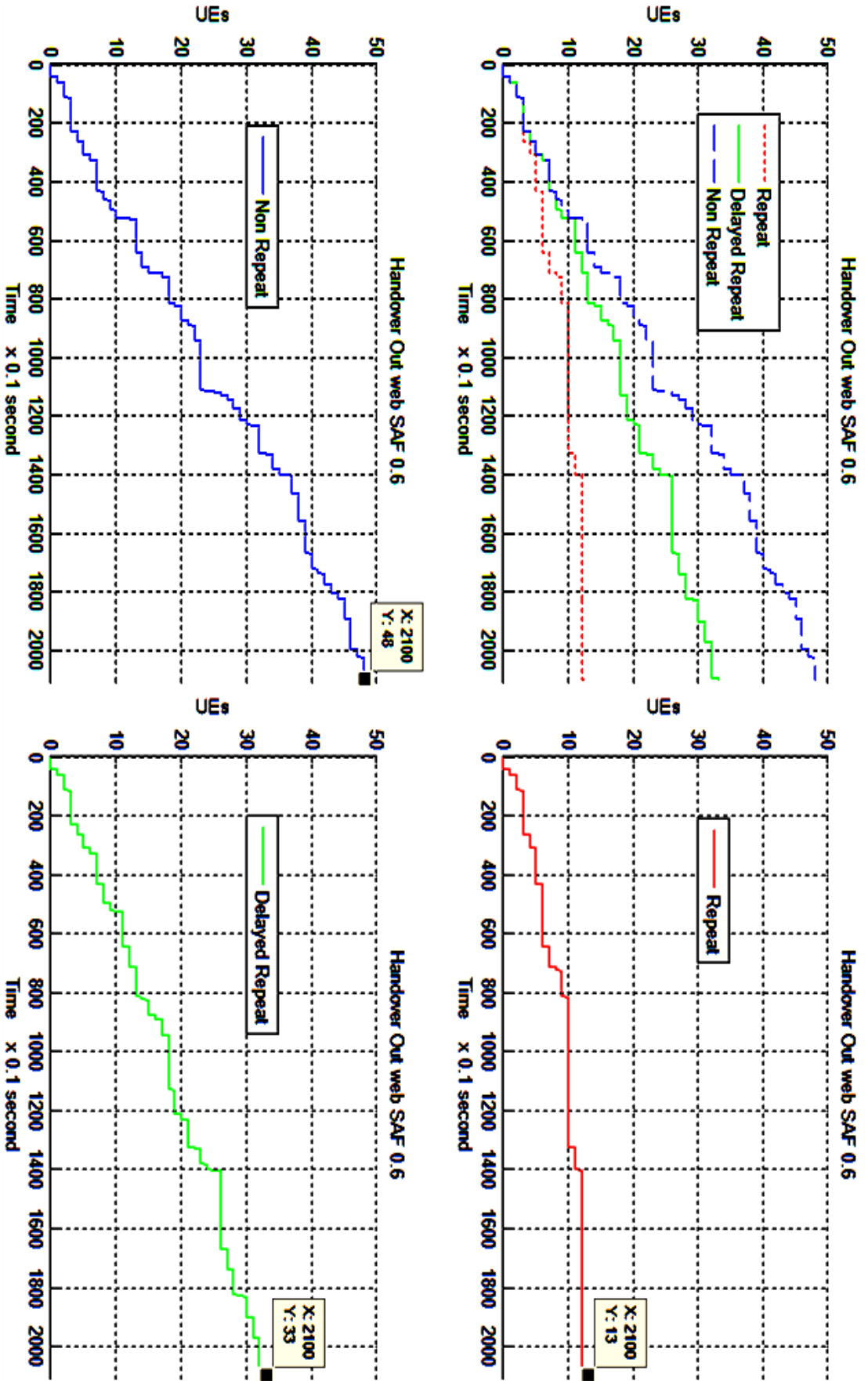

Figure C.6 Handover Out counter when web SAF 60%

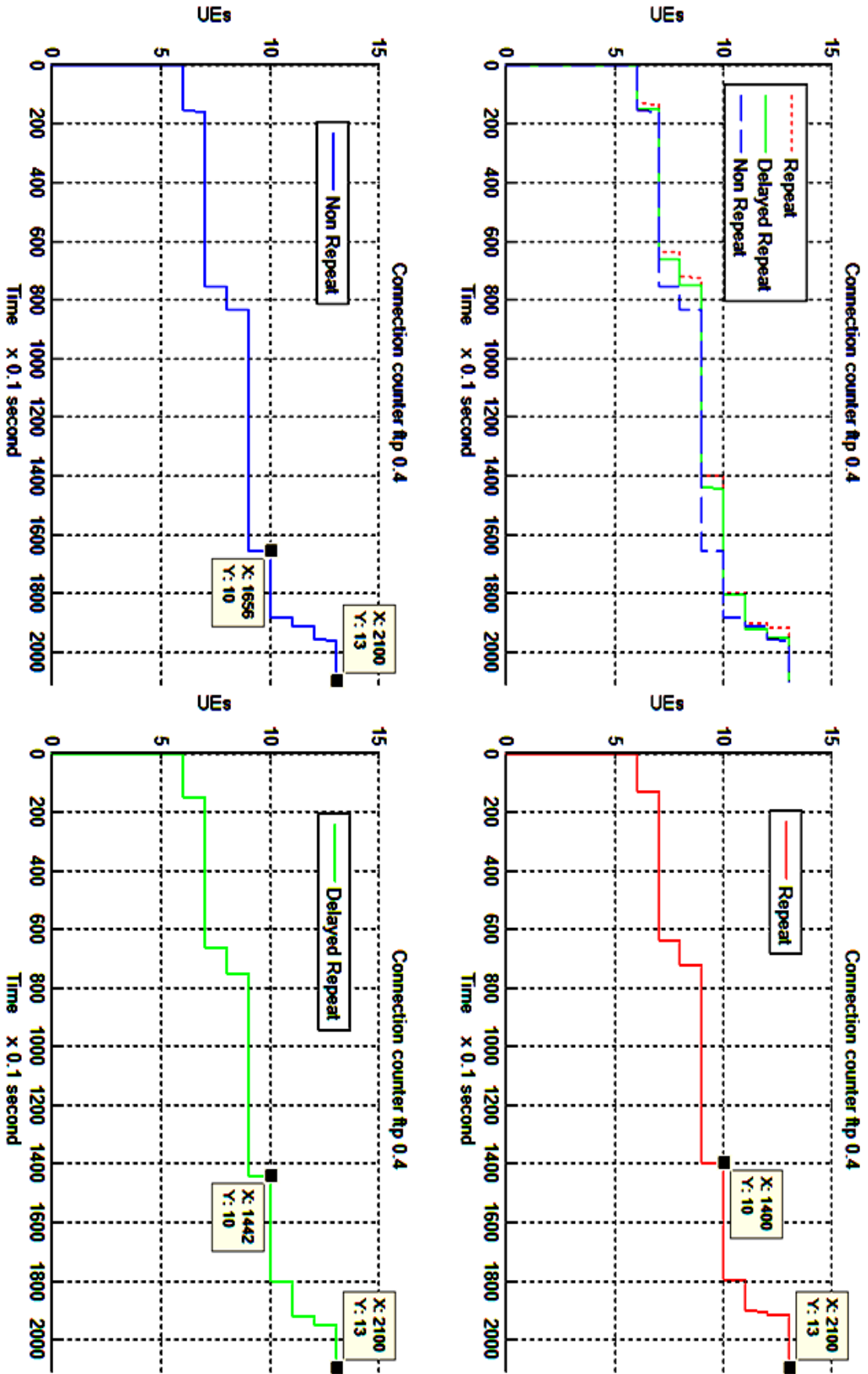

Figure C.7 Connection counter for FTP with SAF 40%

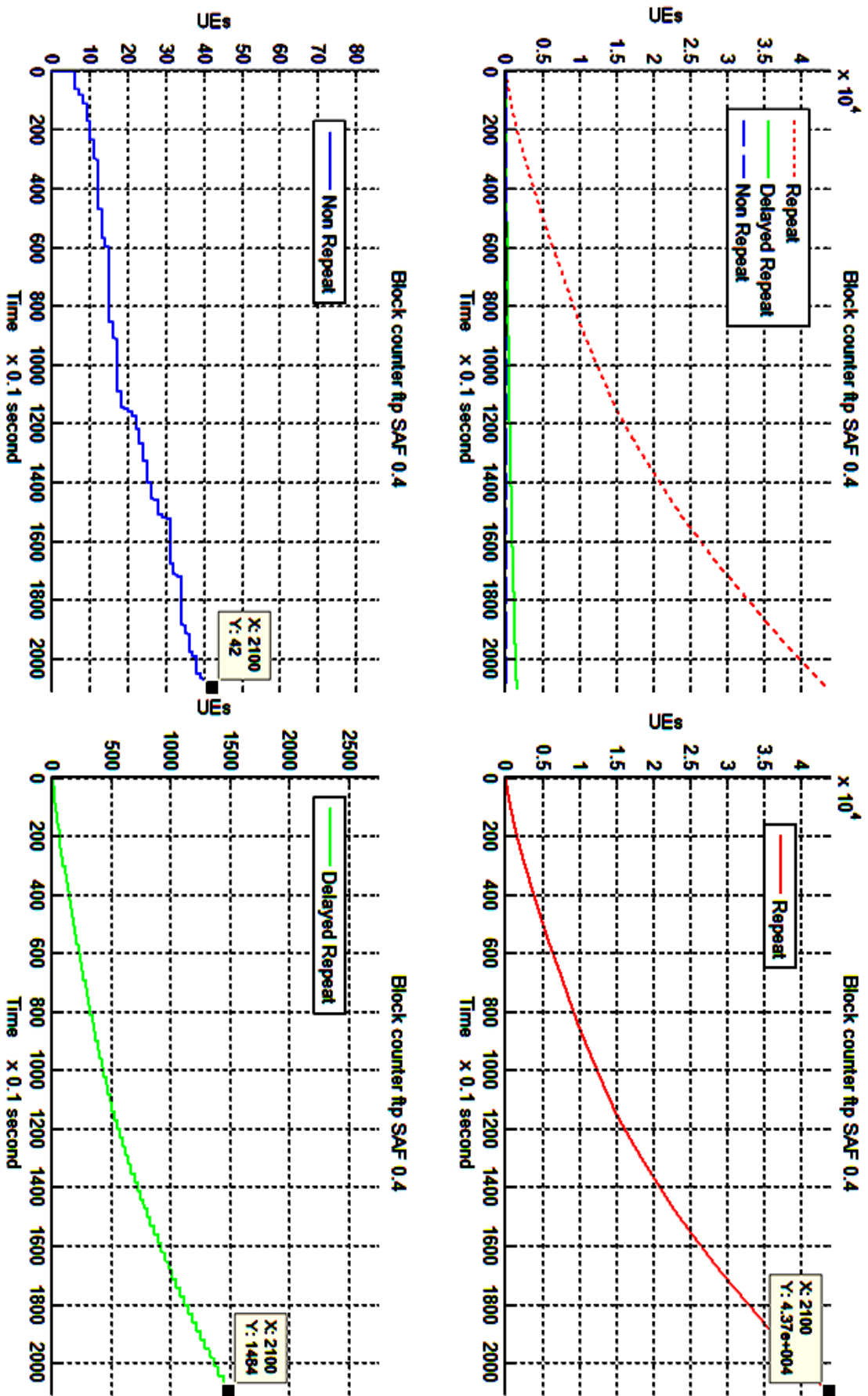

Figure C.8 Block counter for FTP with SAF 40%

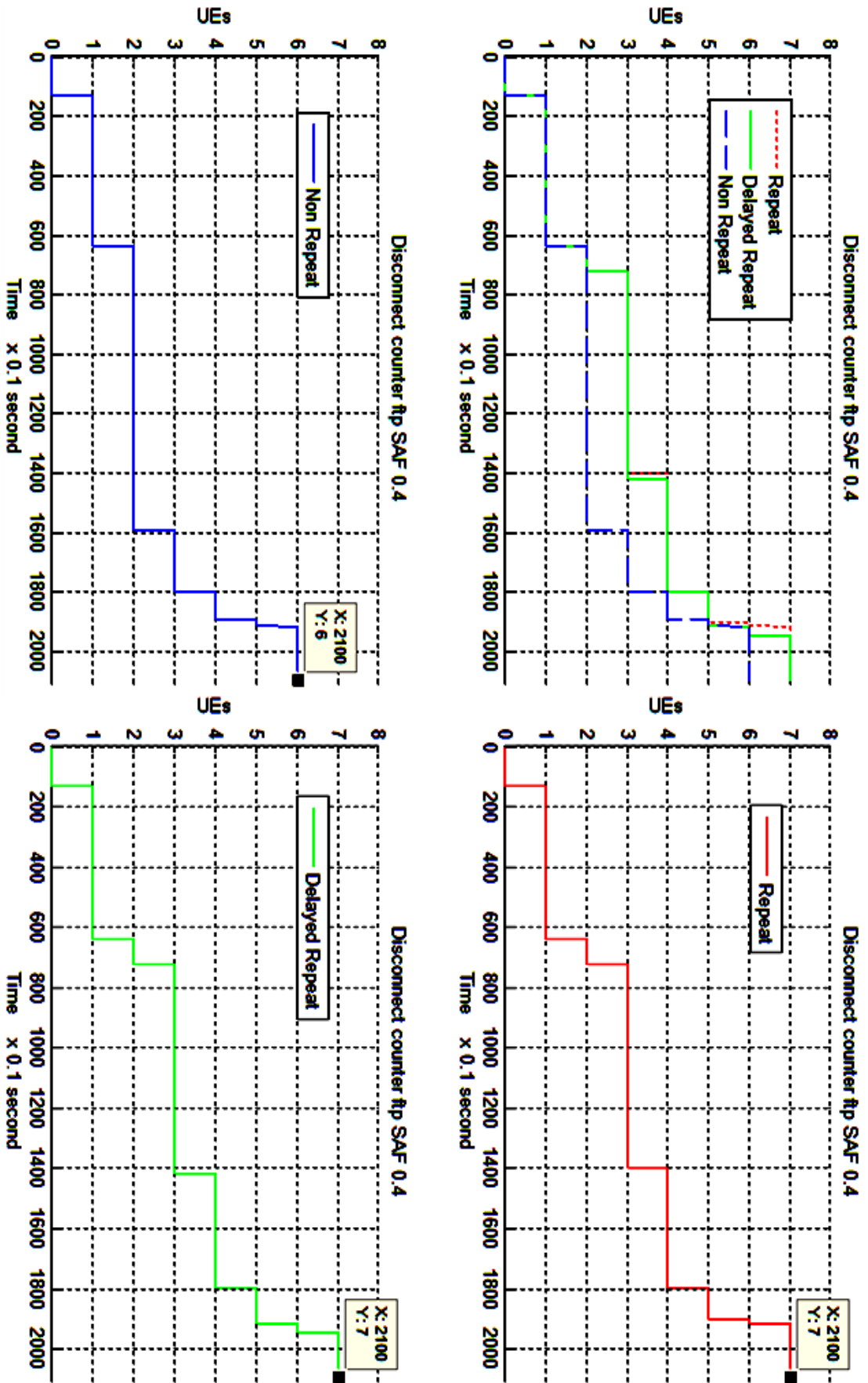

Figure C.9 Disconnect counter for FTP with SAF 40%

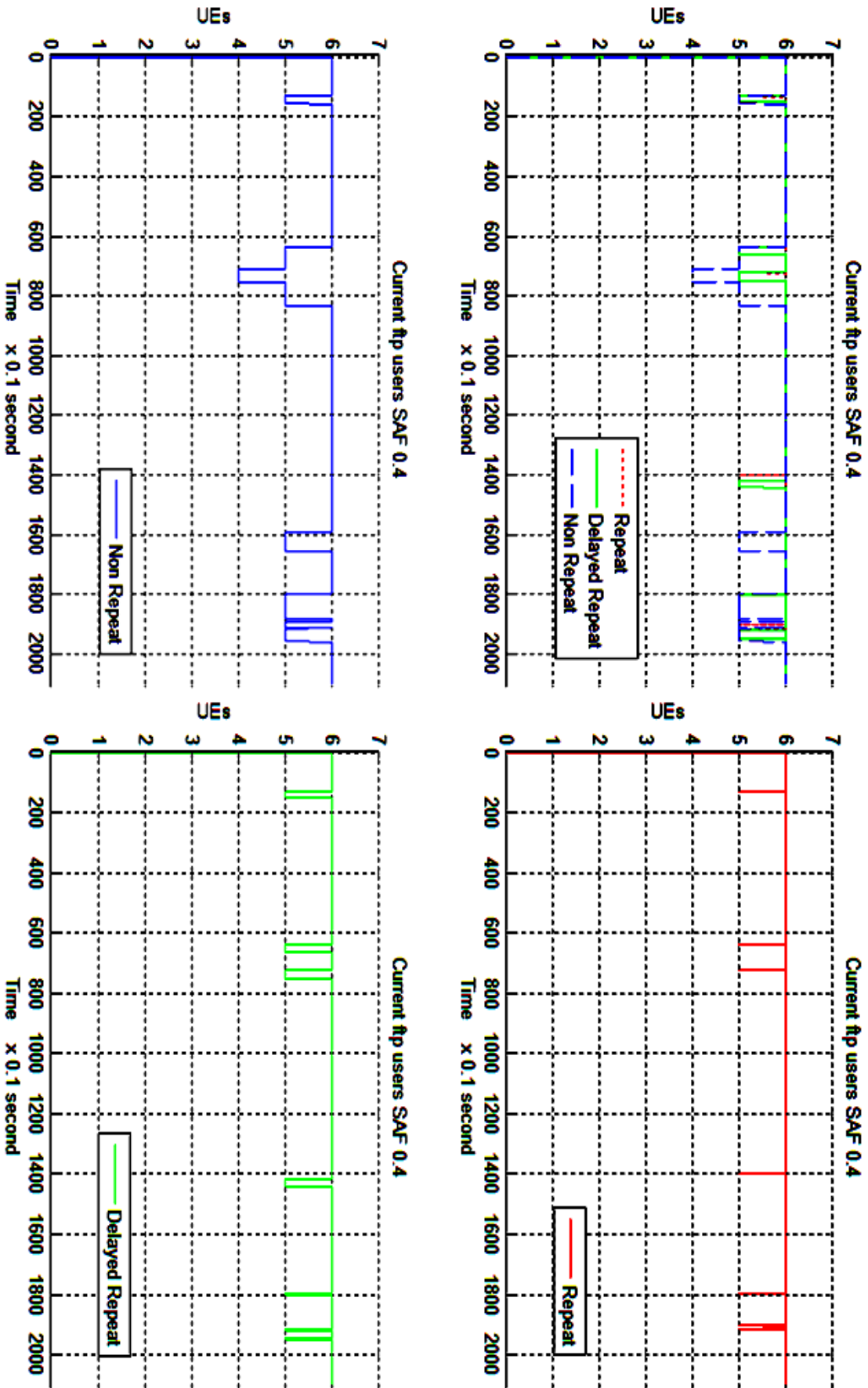

Figure C.10 Current FTP users with SAF 40%

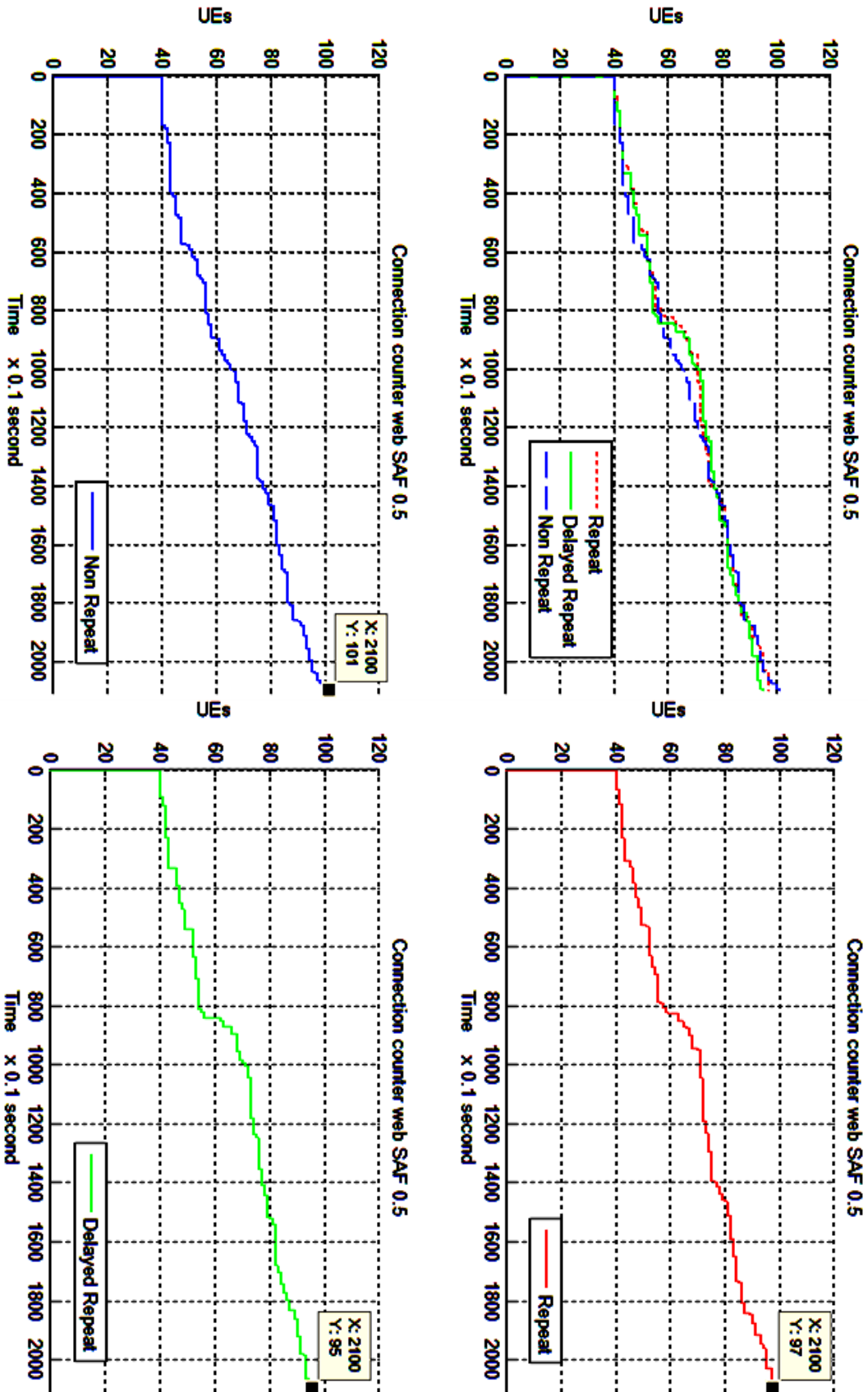

Figure C.11 Connection counter for Web users with SAF 50%

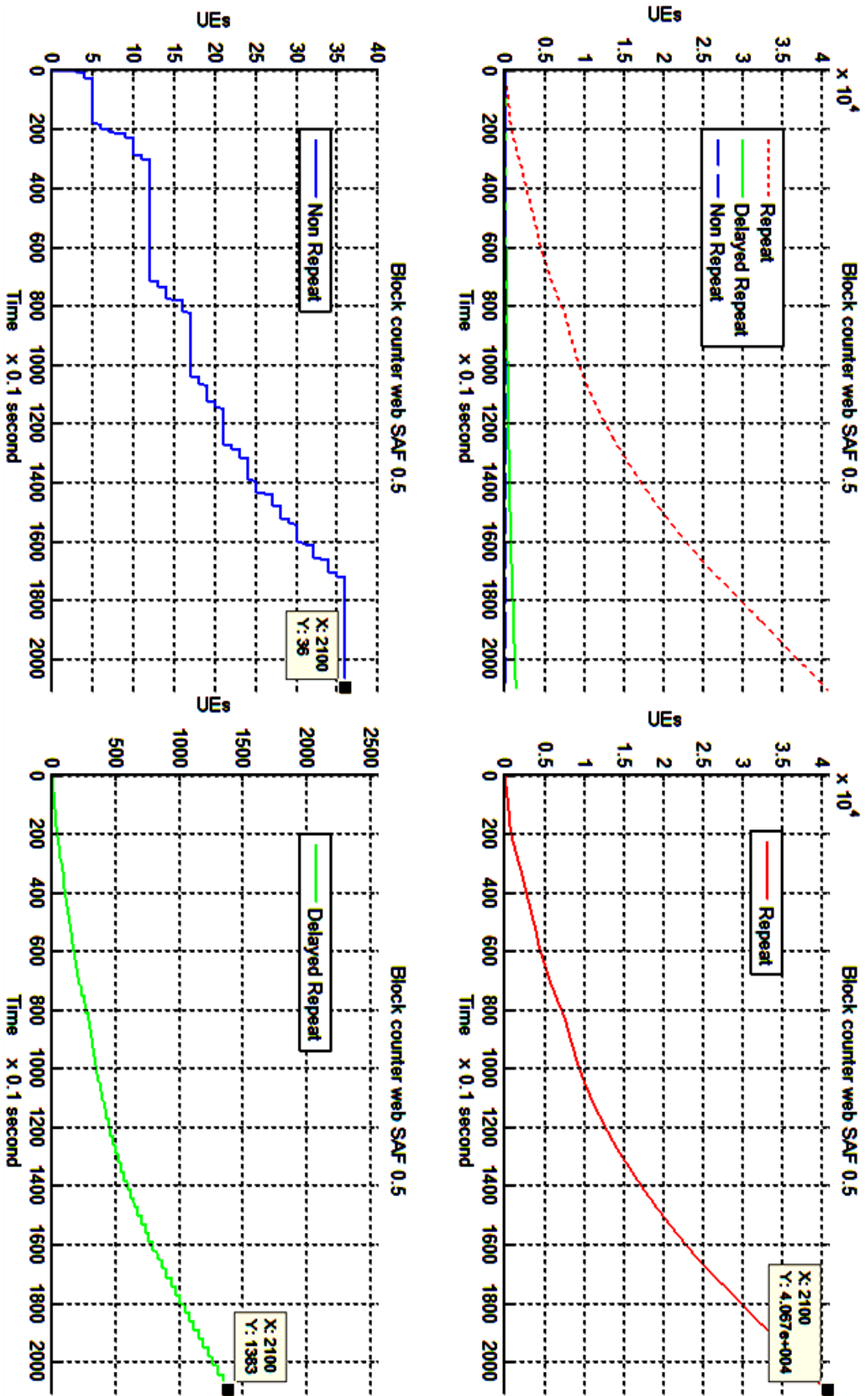

Figure C.12 Block counter for Web users with SAF 50%

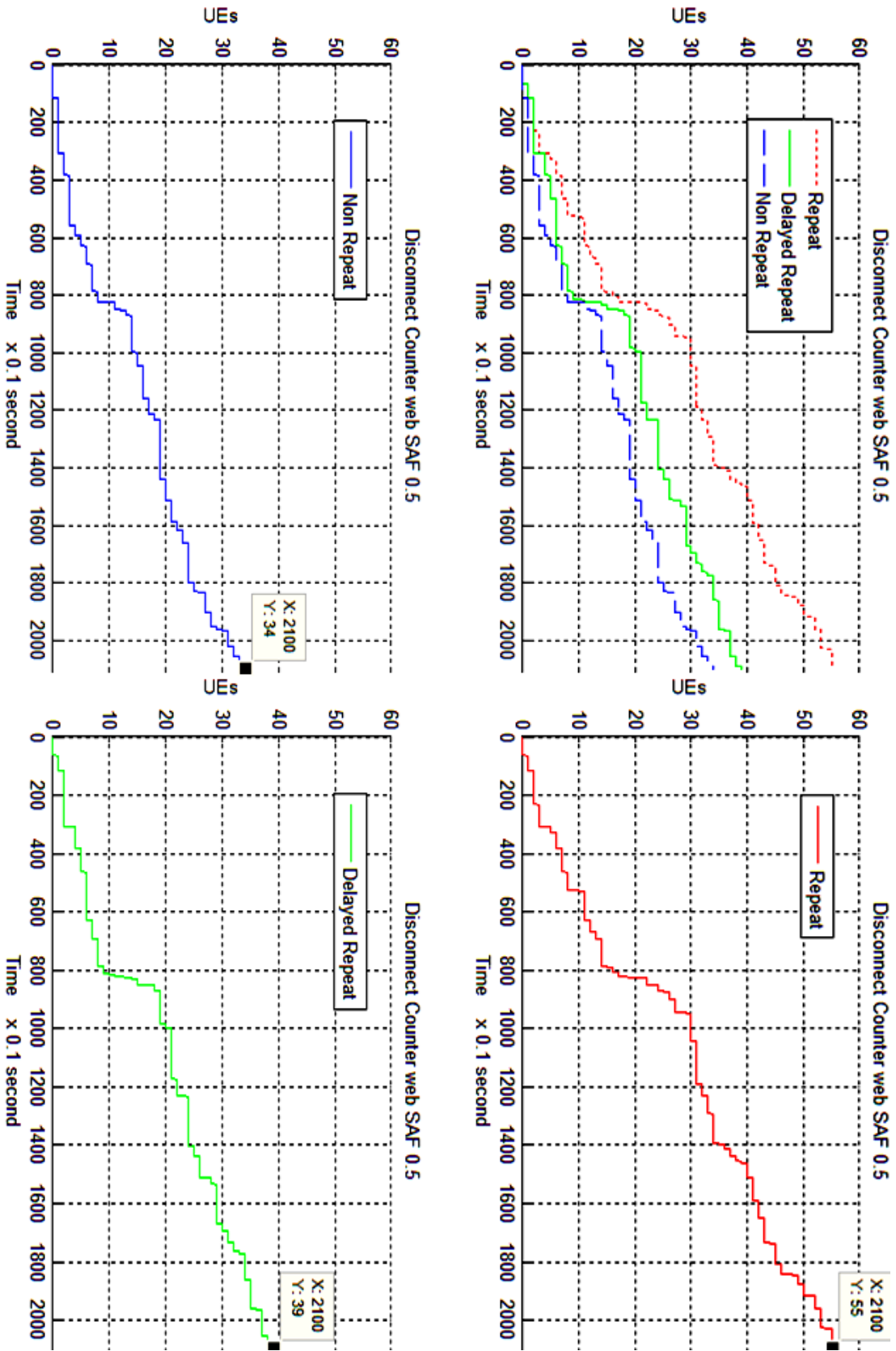

Figure C.13 Disconnect counter for Web users with SAF 50%

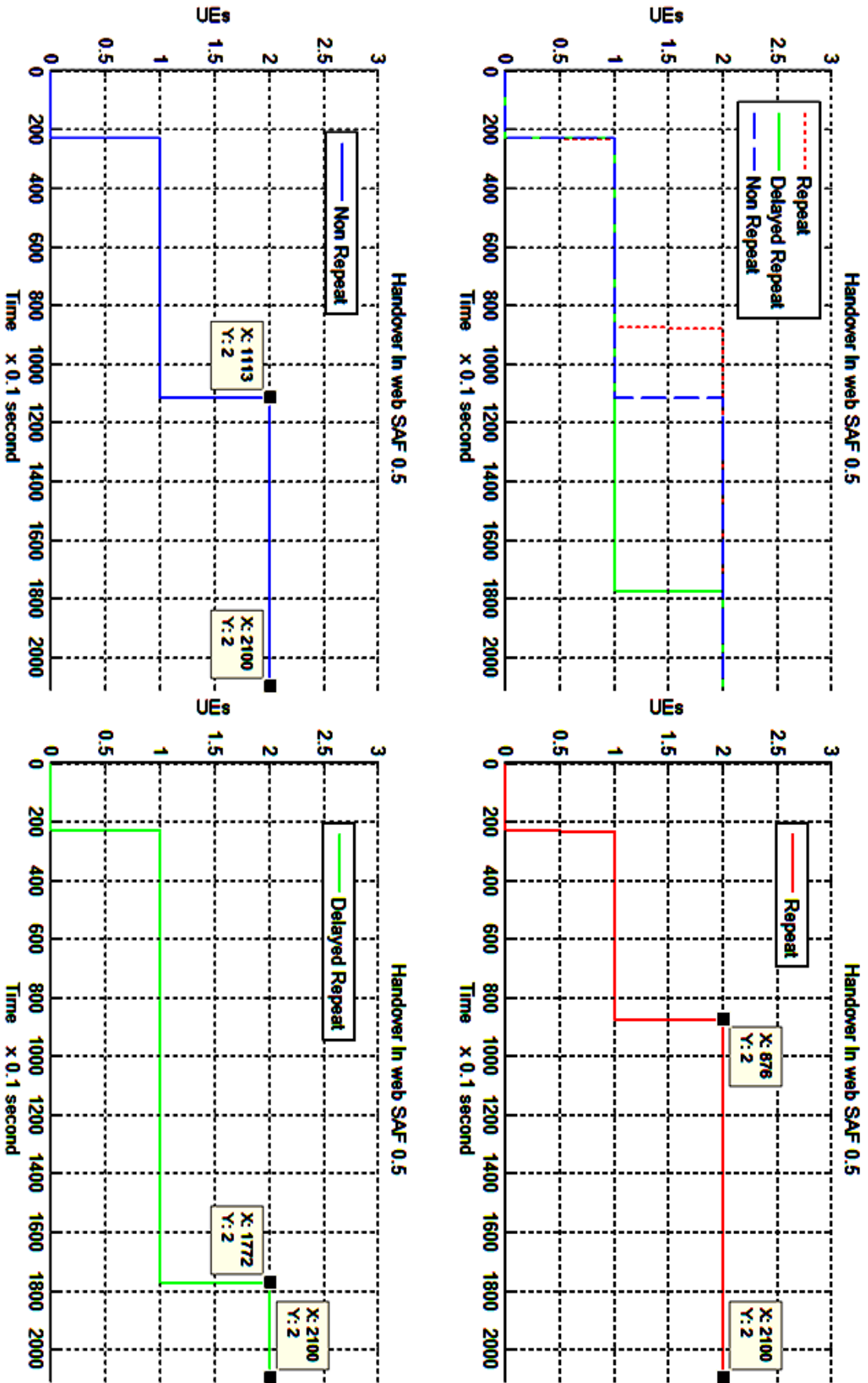

Figure C.14 Handover In counter when web SAF 50%

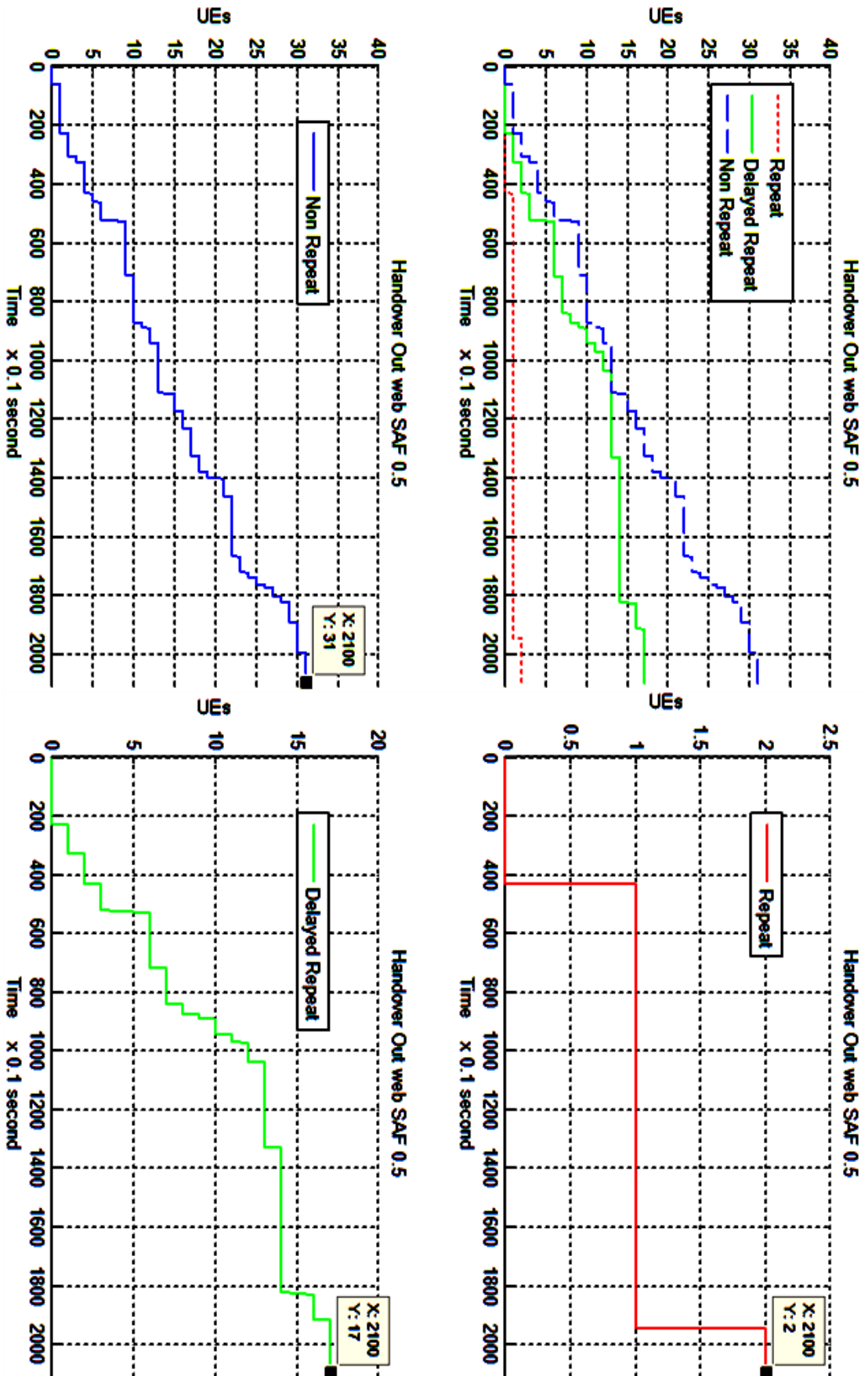

Figure C.15 Handover Out counter when web SAF 50%

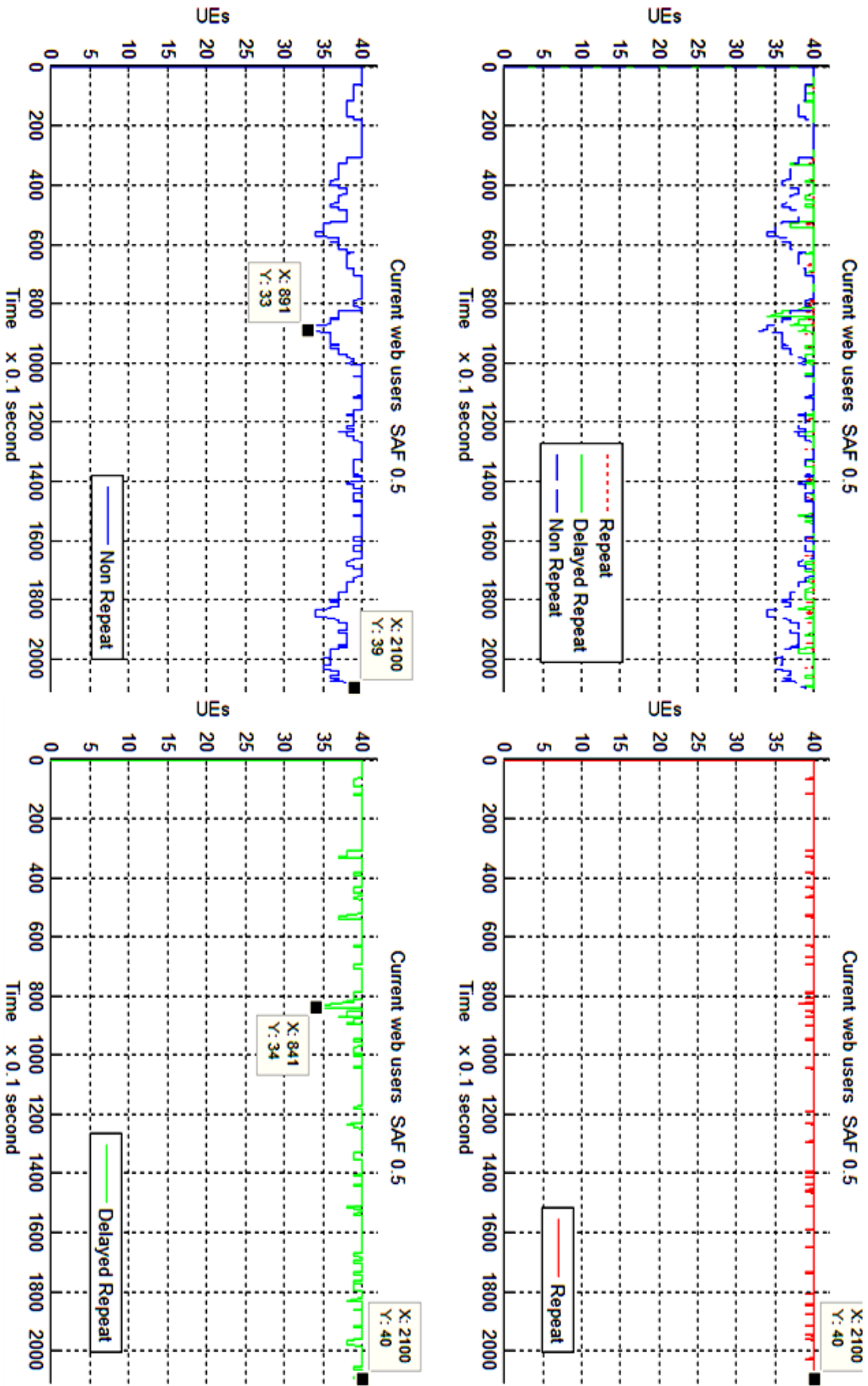

Figure C.16 Current Web users with SAF 50%

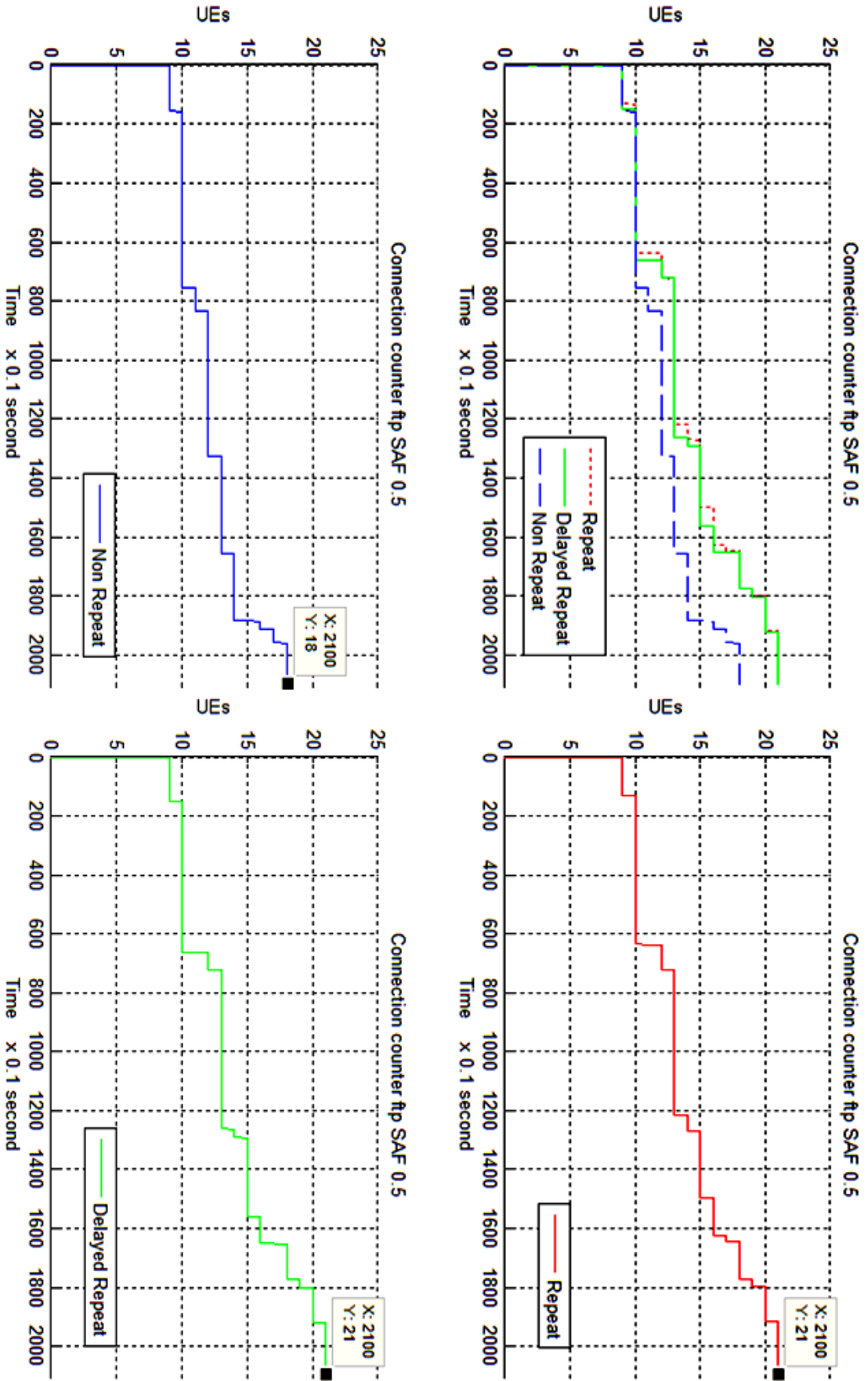

Figure C.17 Connection counter for FTP with SAF 50%

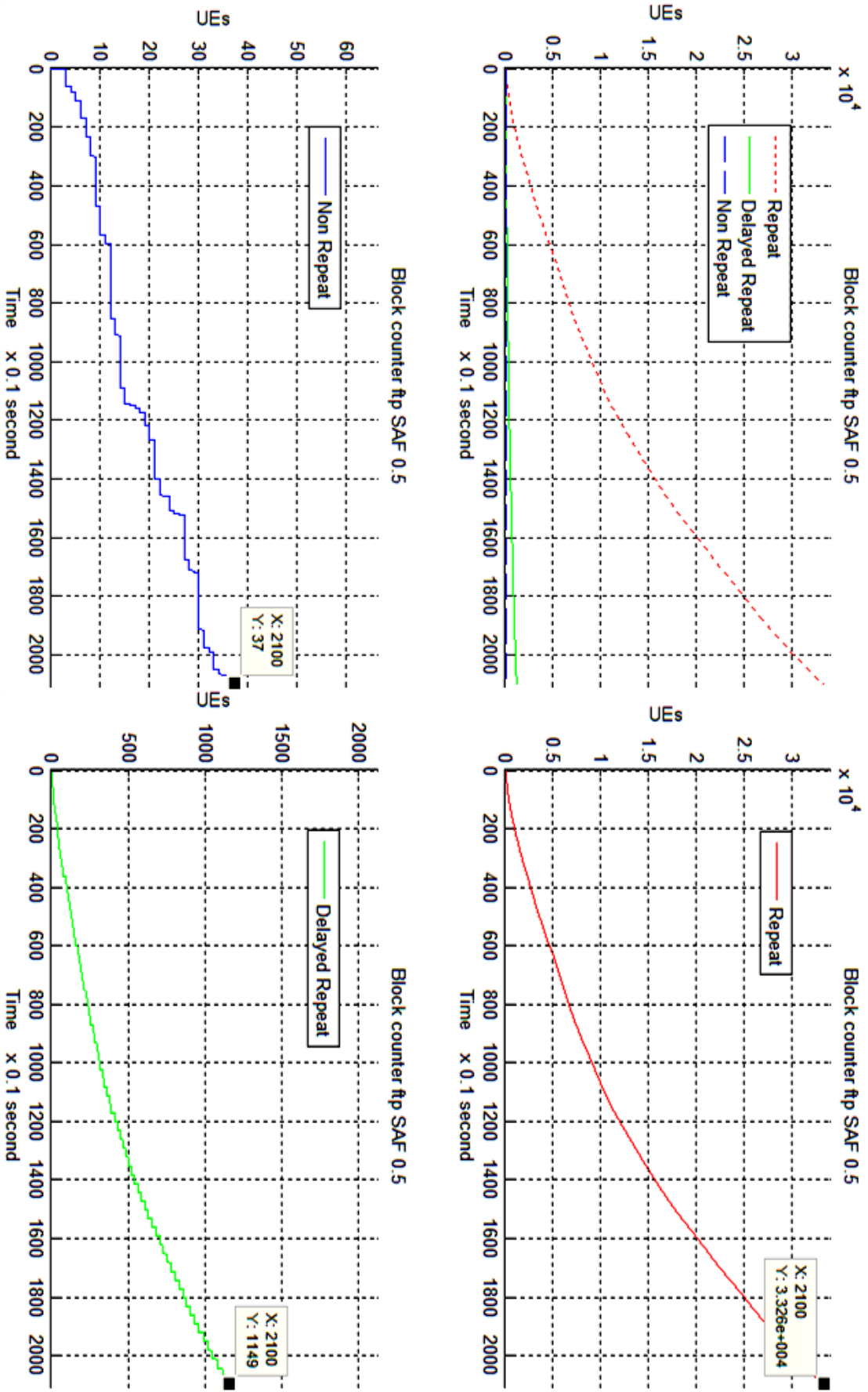

Figure C.18 Block counter for FTP with SAF 50%

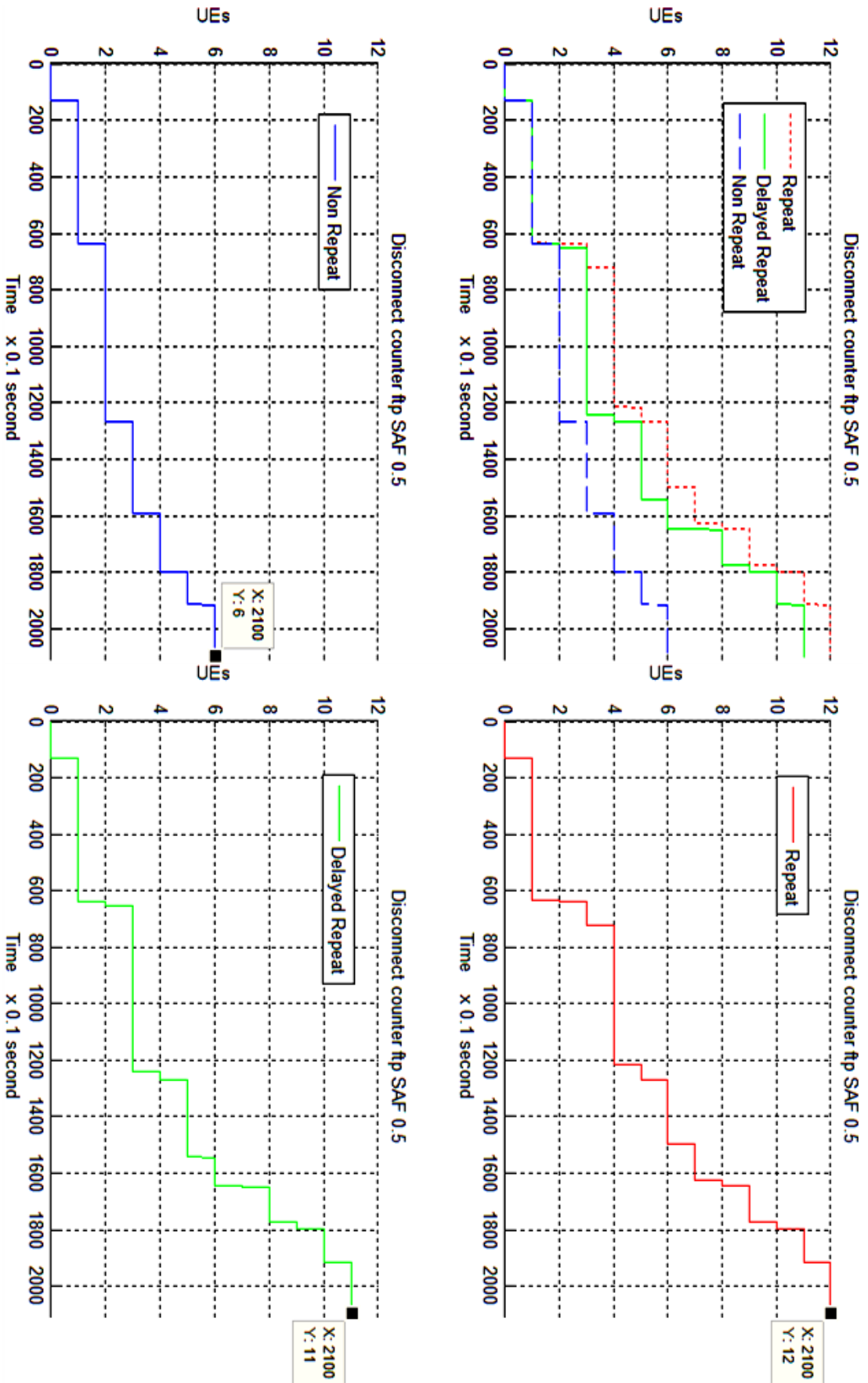

Figure C.19 Disconnect counter for FTP with SAF 50%

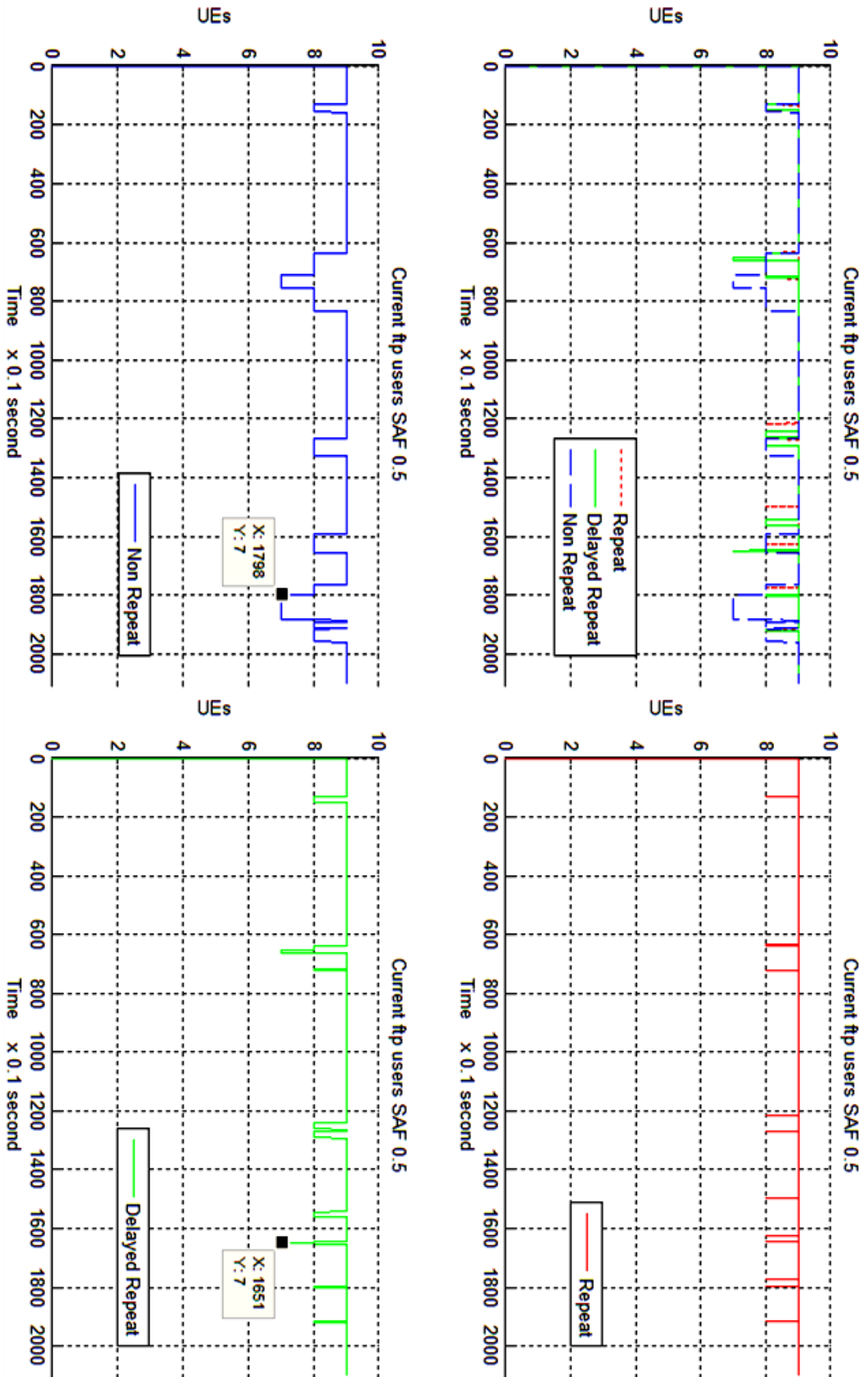

Figure C.20 Current FTP users with SAF 50%

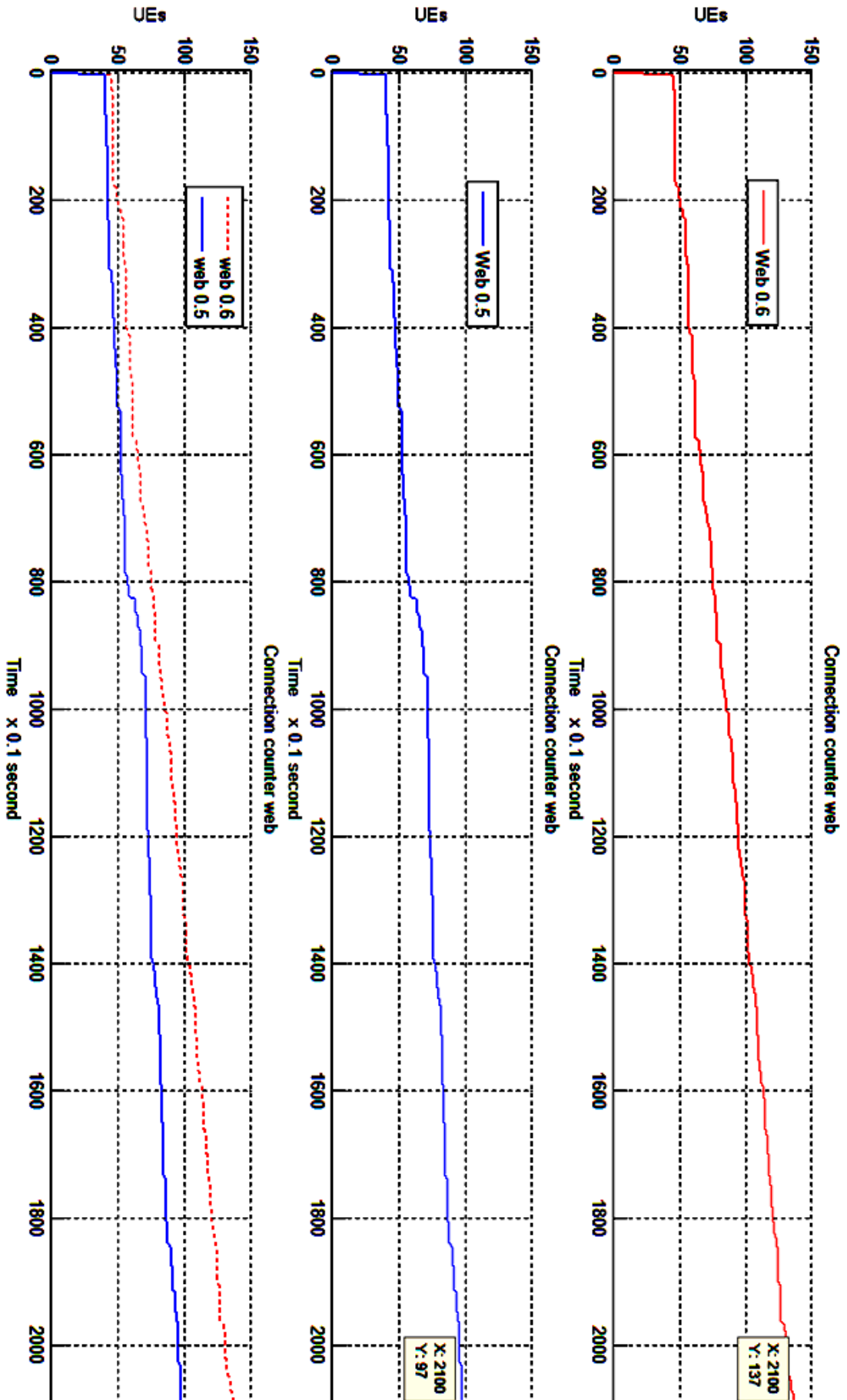

Figure C.21 Connection counter comparison for Web users varying SAF

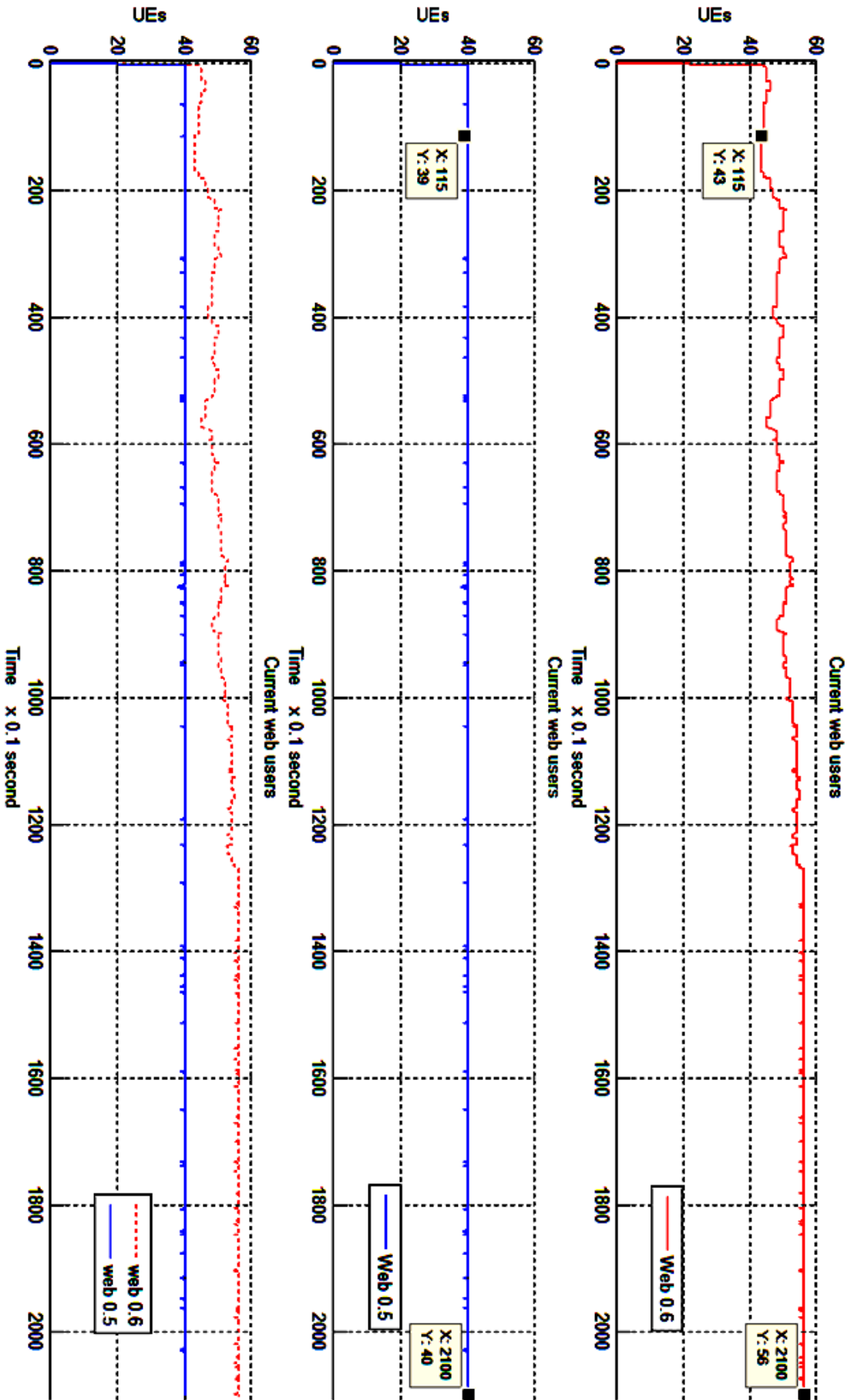

Figure C.22 Current Web users comparison for Web users varying SAF

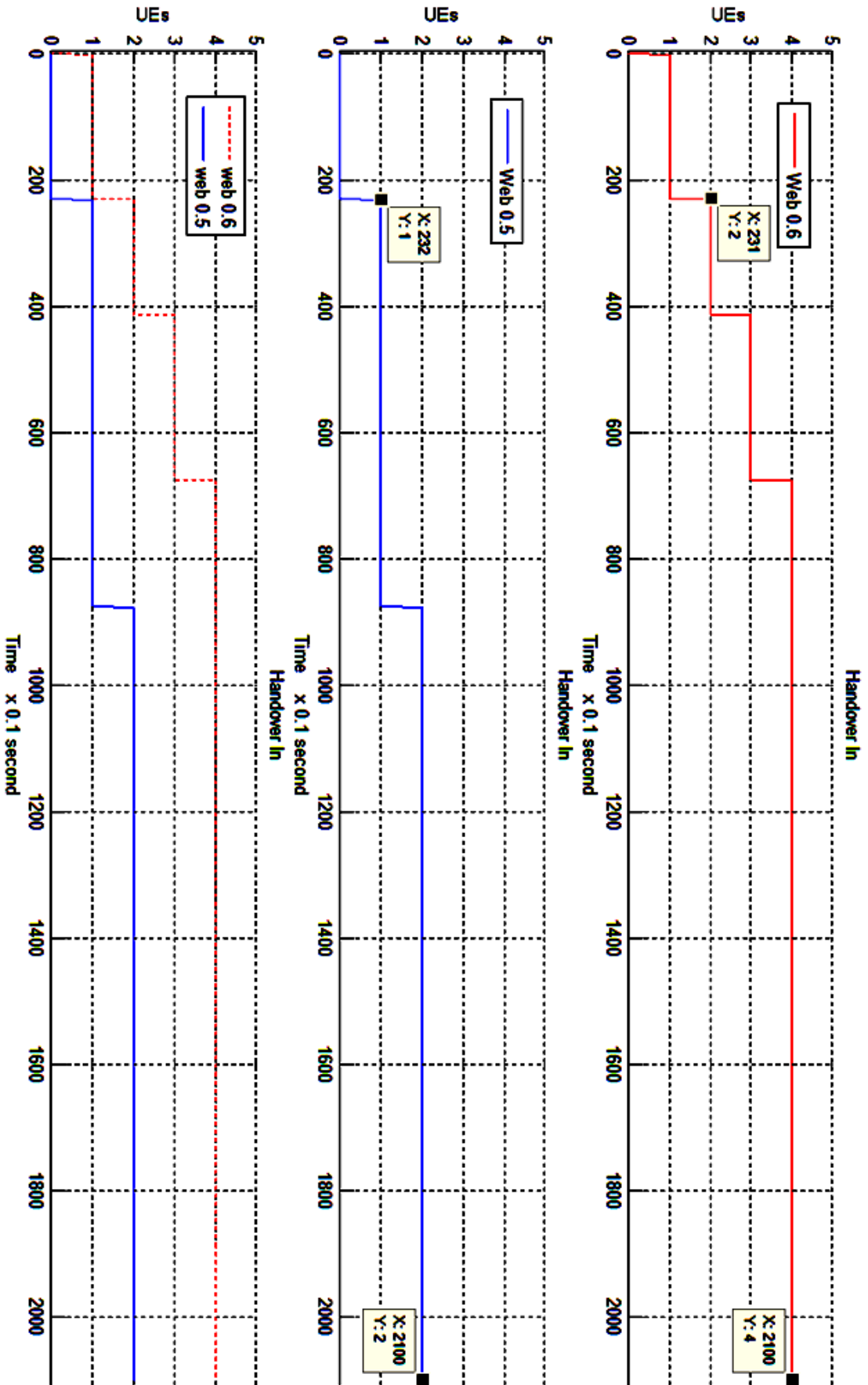

Figure C.23 Handover In counter comparison when varying SAF

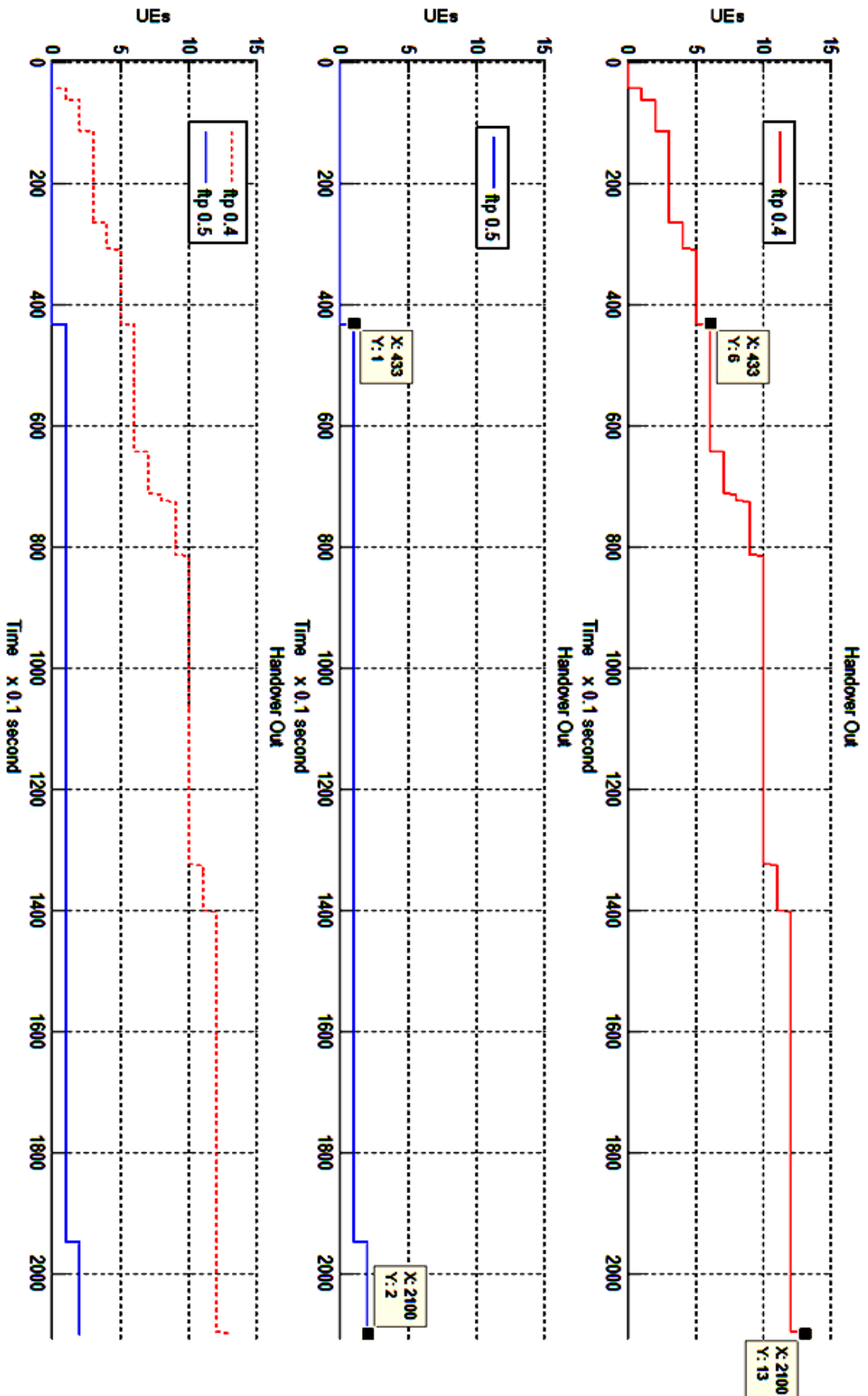

Figure C.24 Handover Out counter comparison when varying SAF

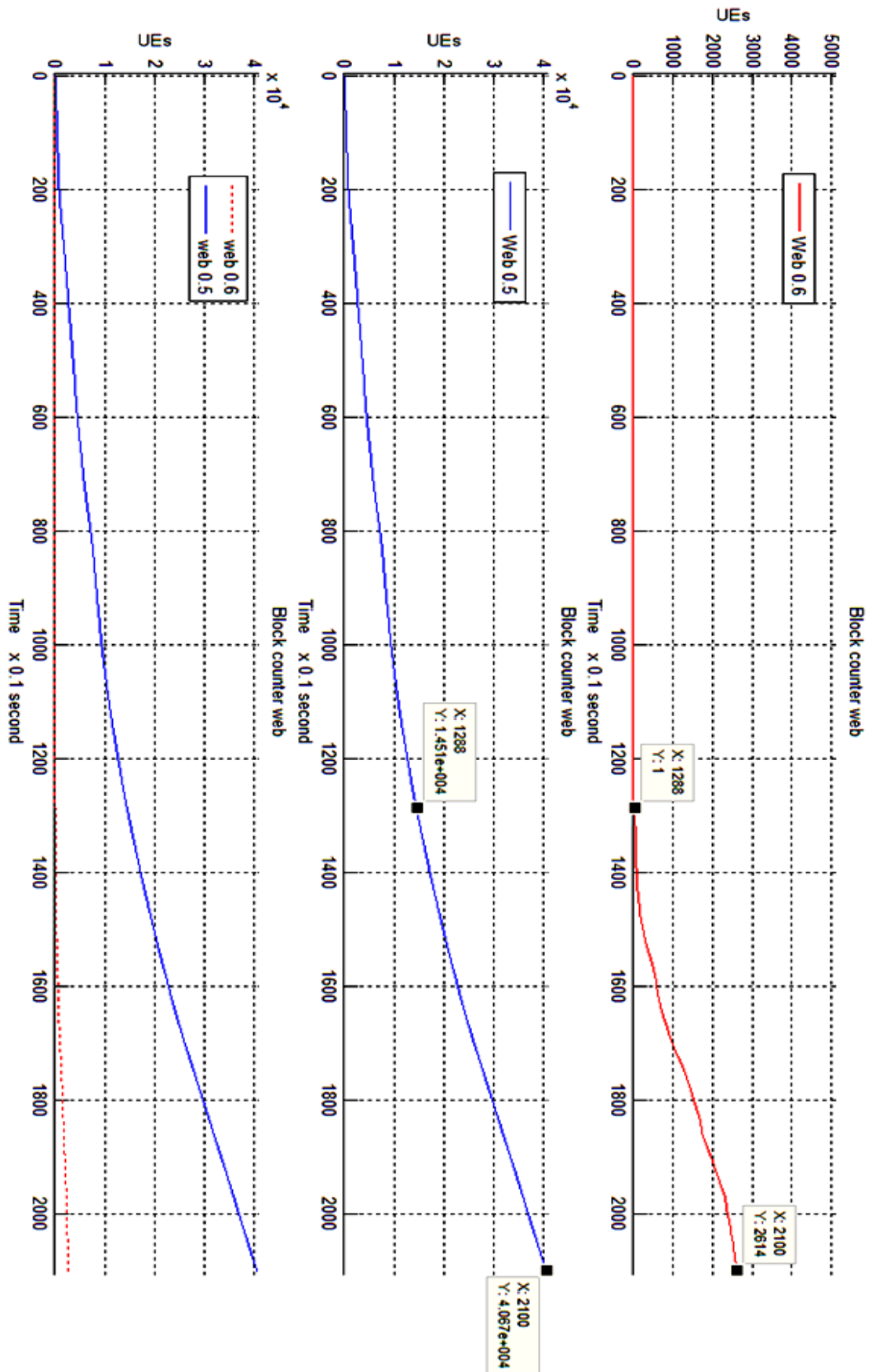

Figure C.25 Block counter comparison for Web users varying SAF

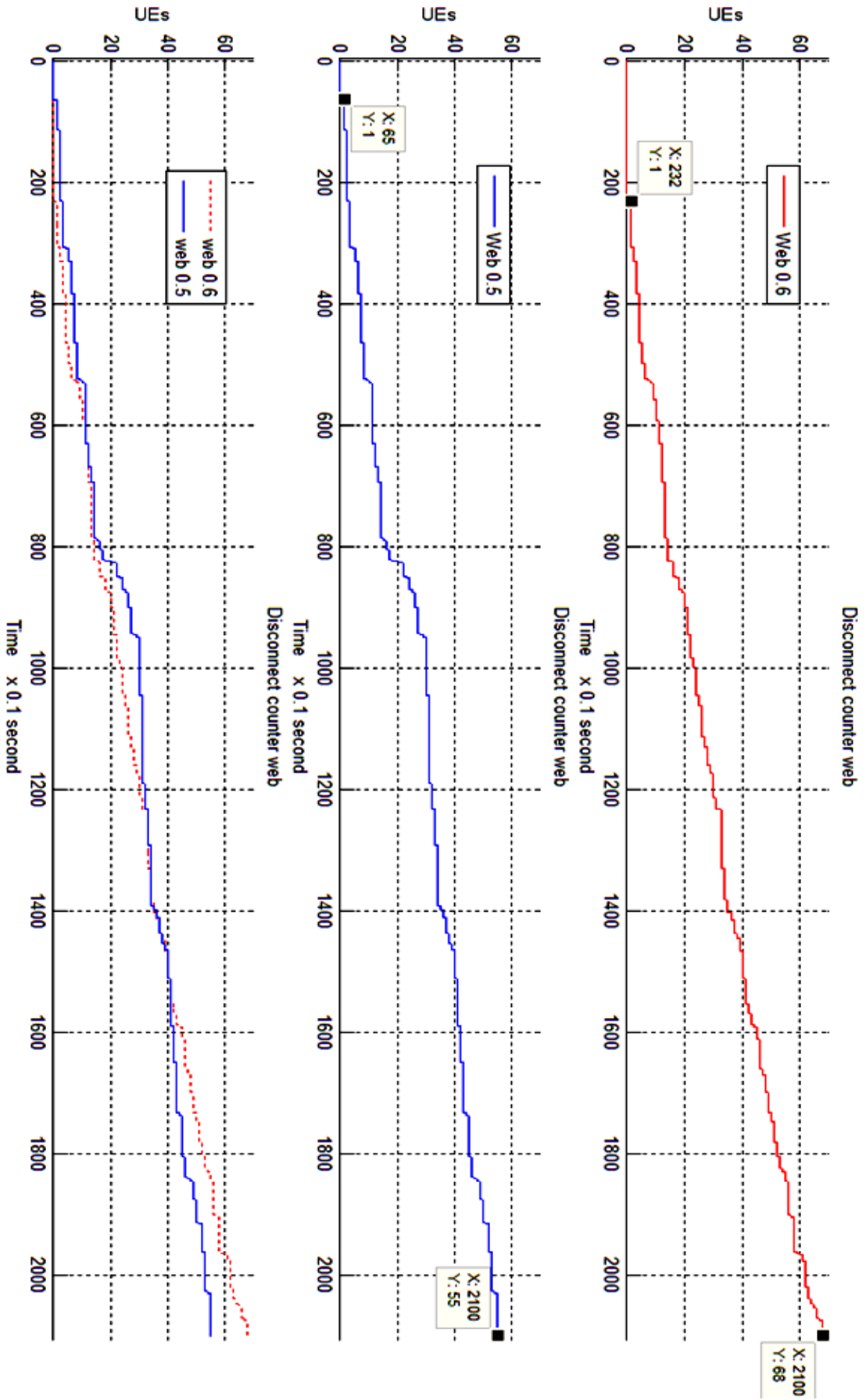

Figure C.26 Disconnect counter comparison for Web users varying SAF

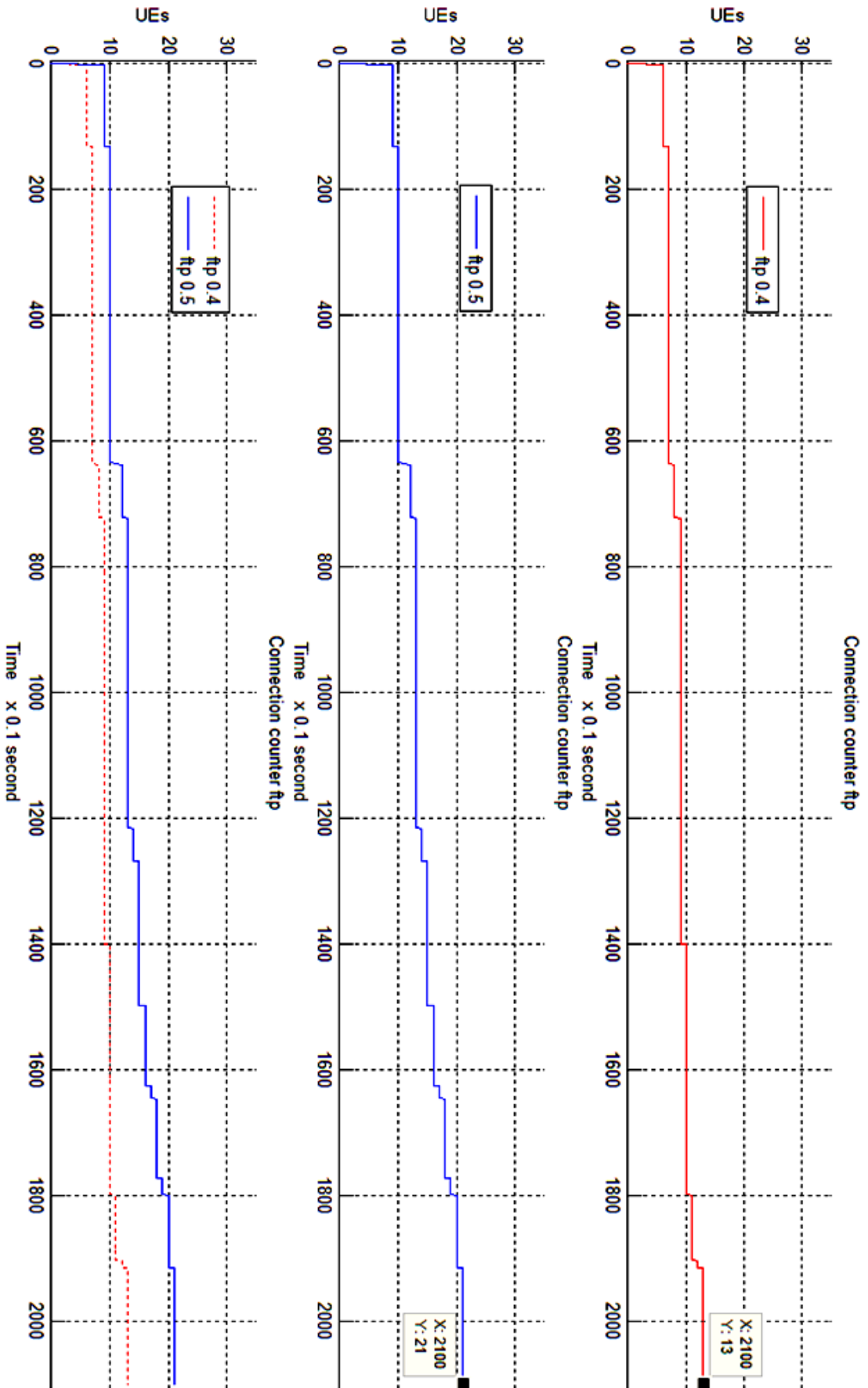

Figure C.27 Connection counter comparison for FTP users varying SAF

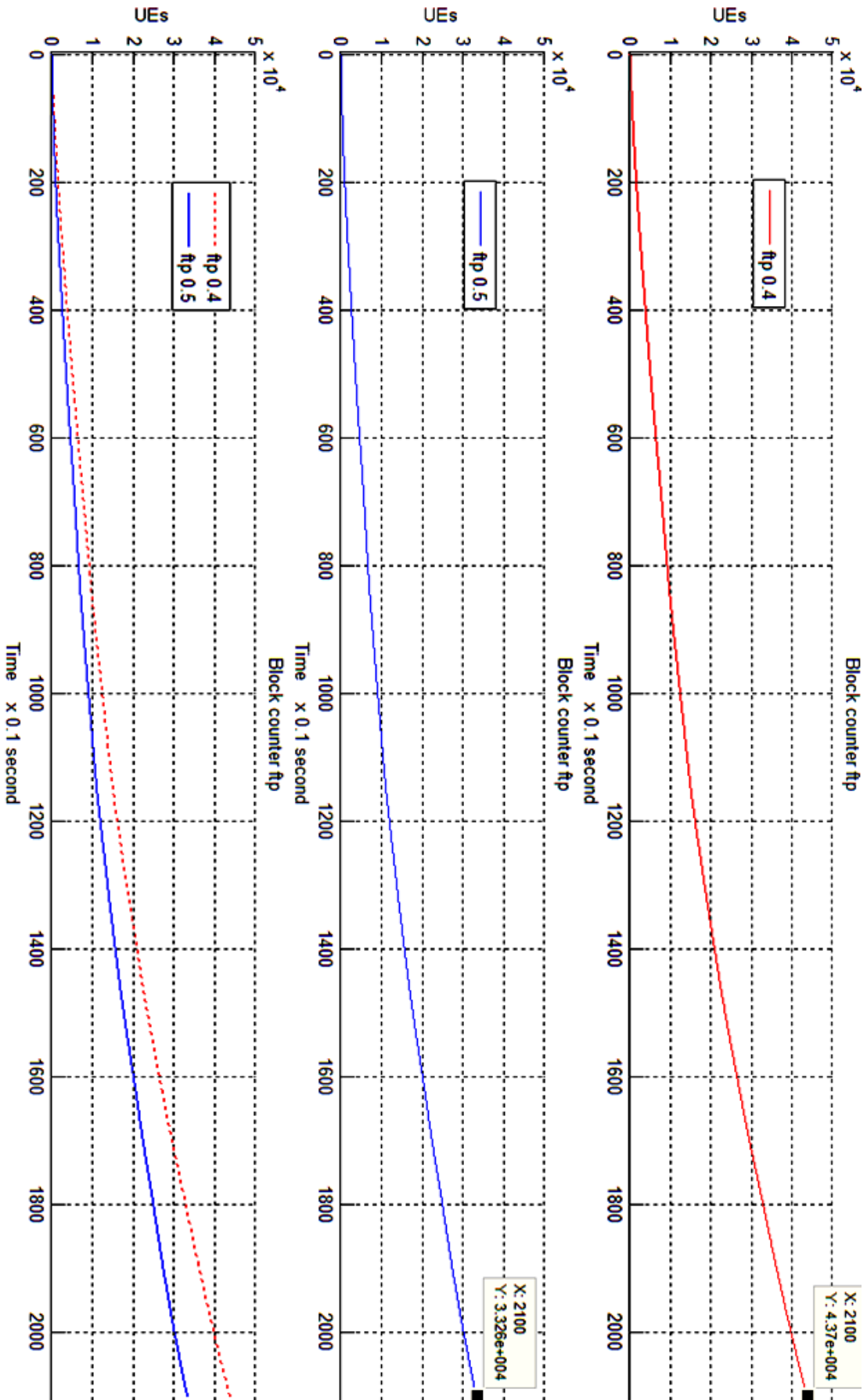

Figure C.28 Block counter comparison for FTP users varying SAF

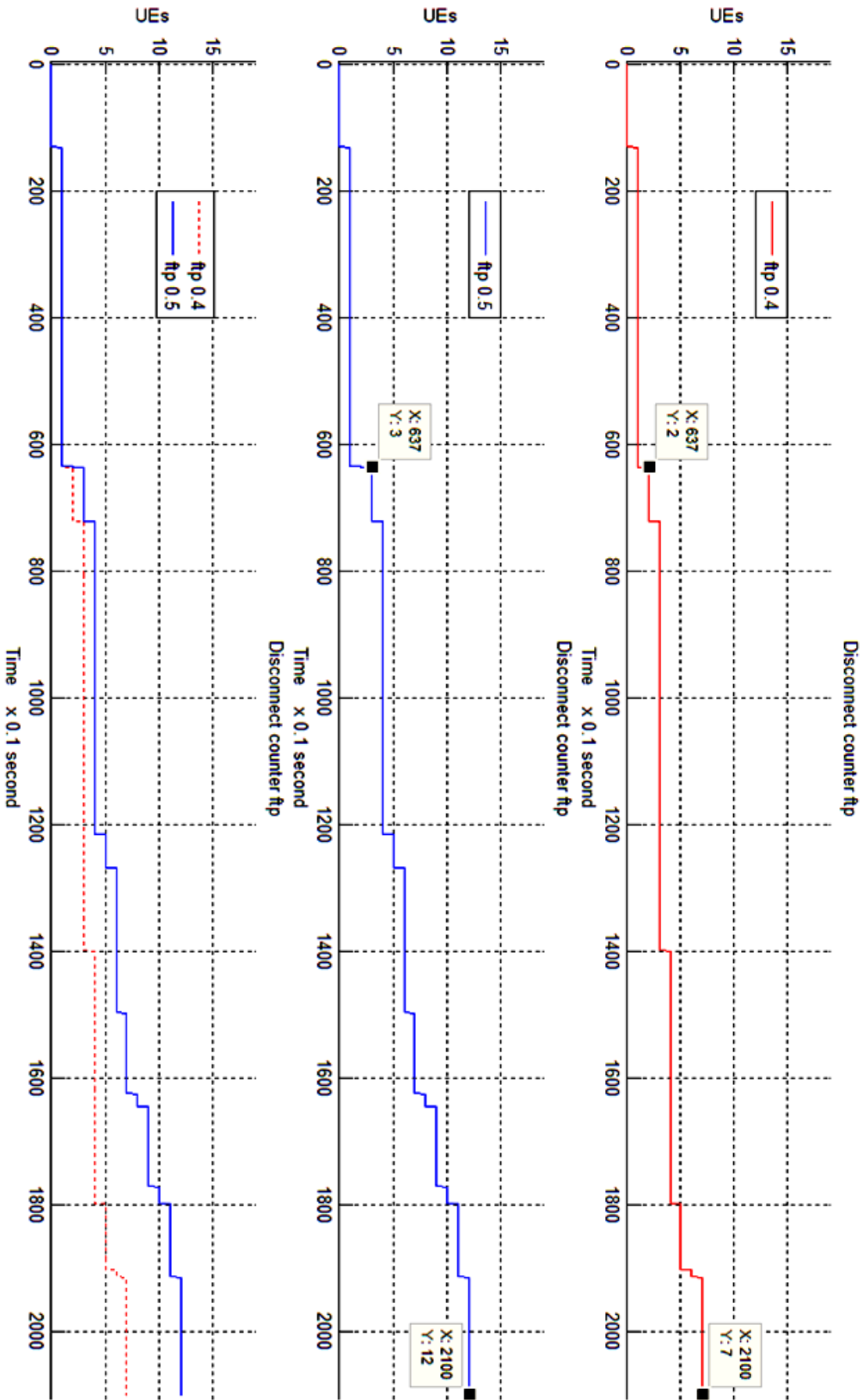

Figure C.29 Disconnect counter comparison for FTP users varying SAF

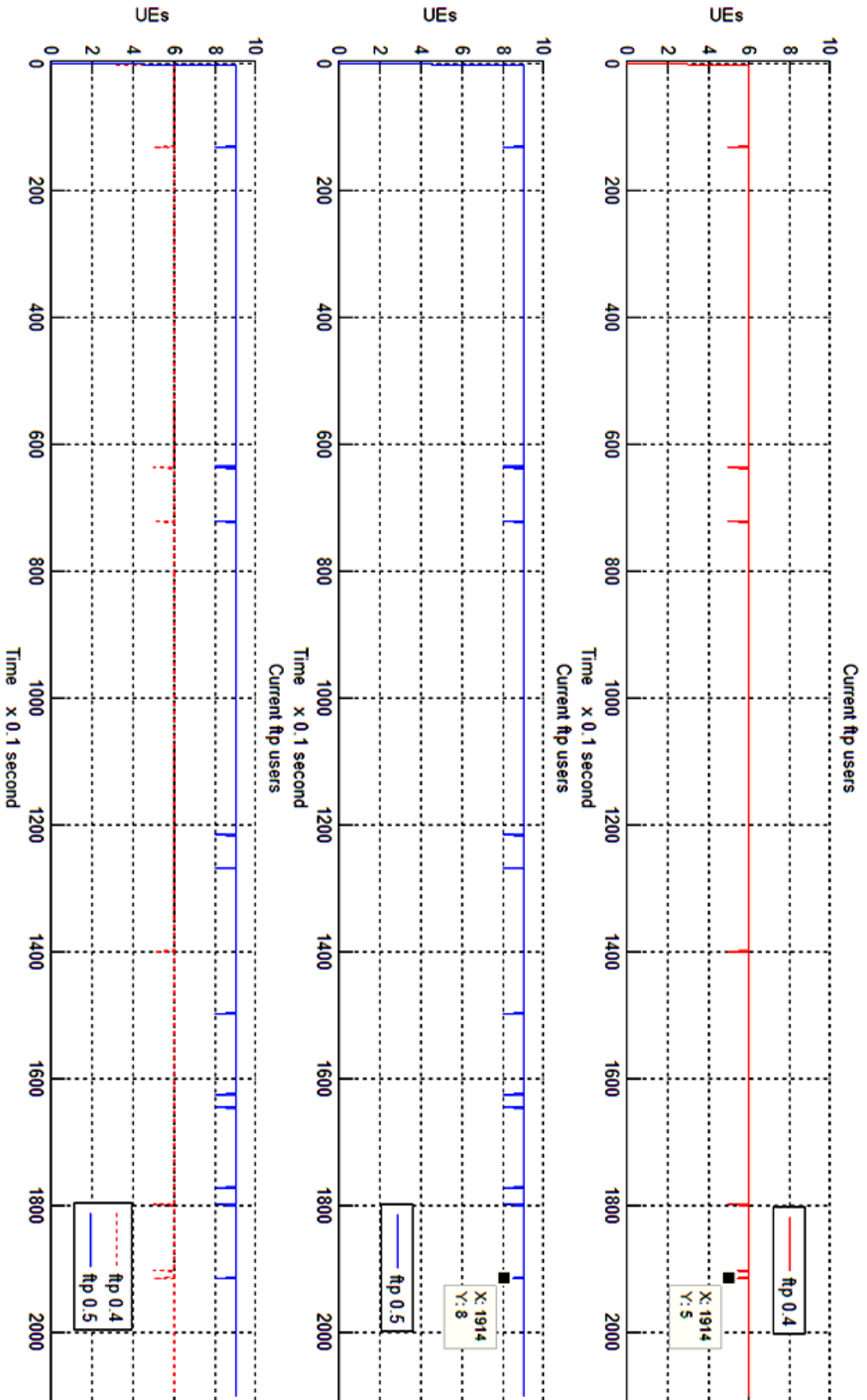

Figure C.30 Current FTP users comparison varying SAF

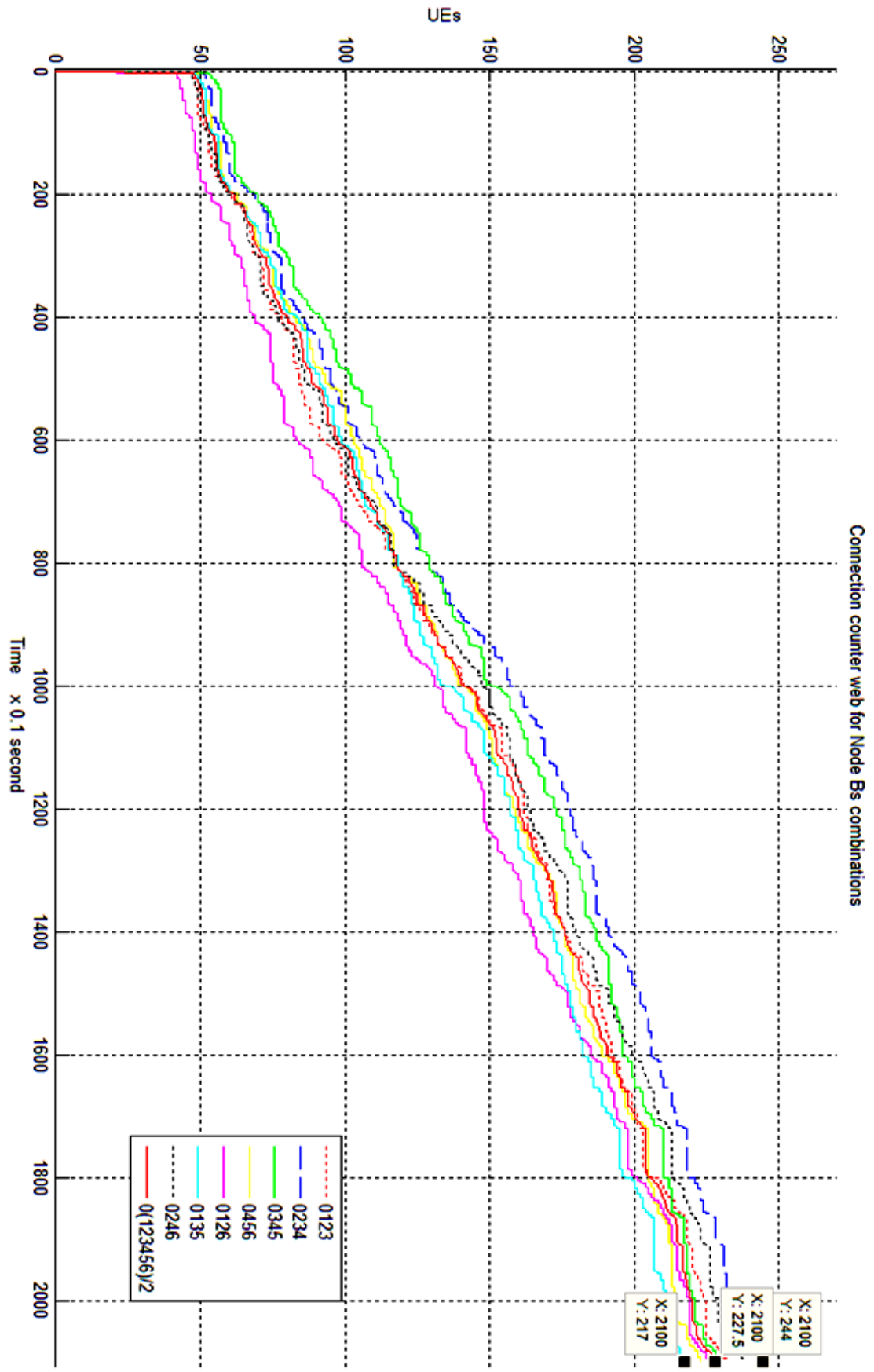

Figure C.31 Web connection counter for splitted Node Bs

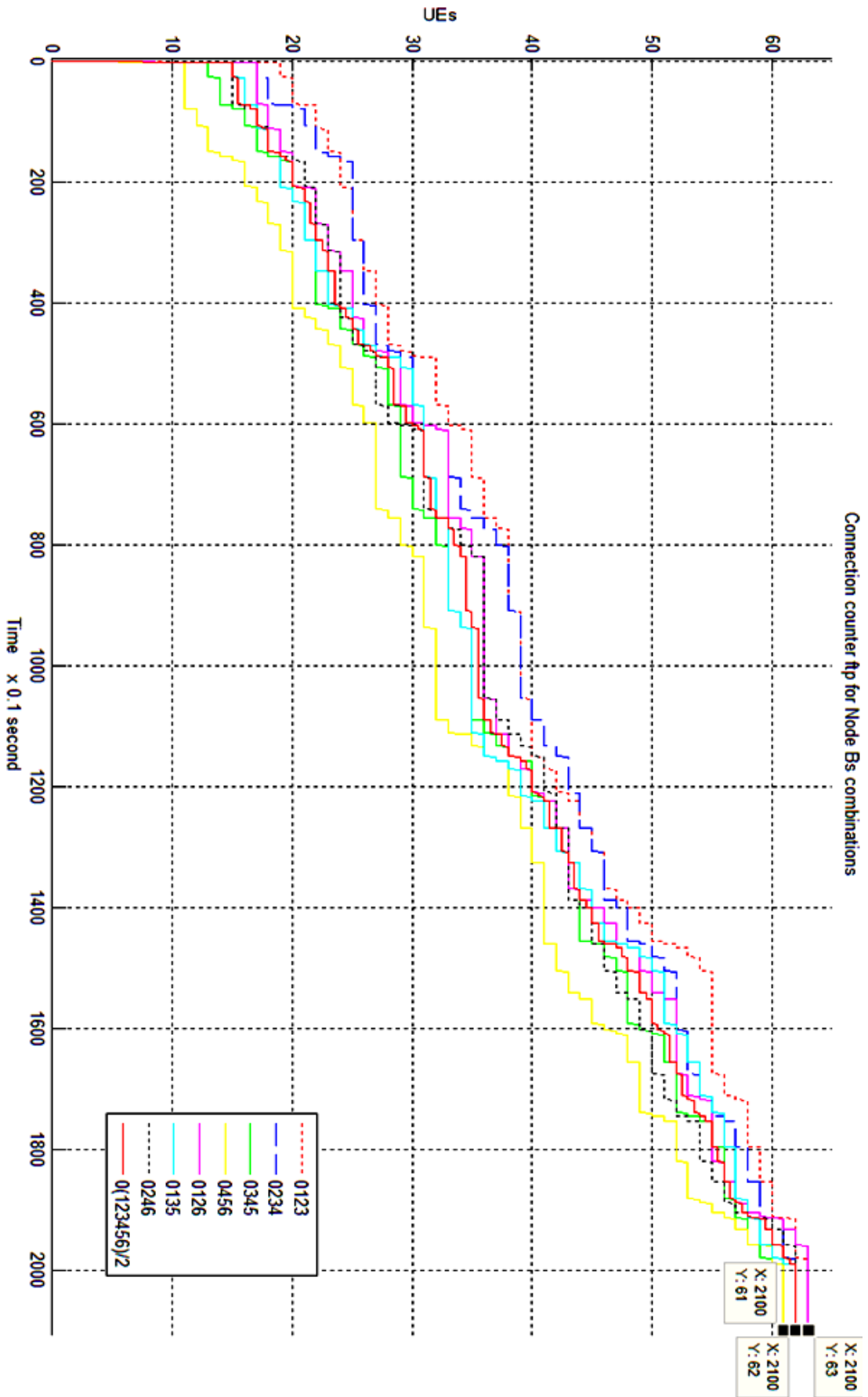

Figure C.32 FTP connection counter for splitted Node Bs

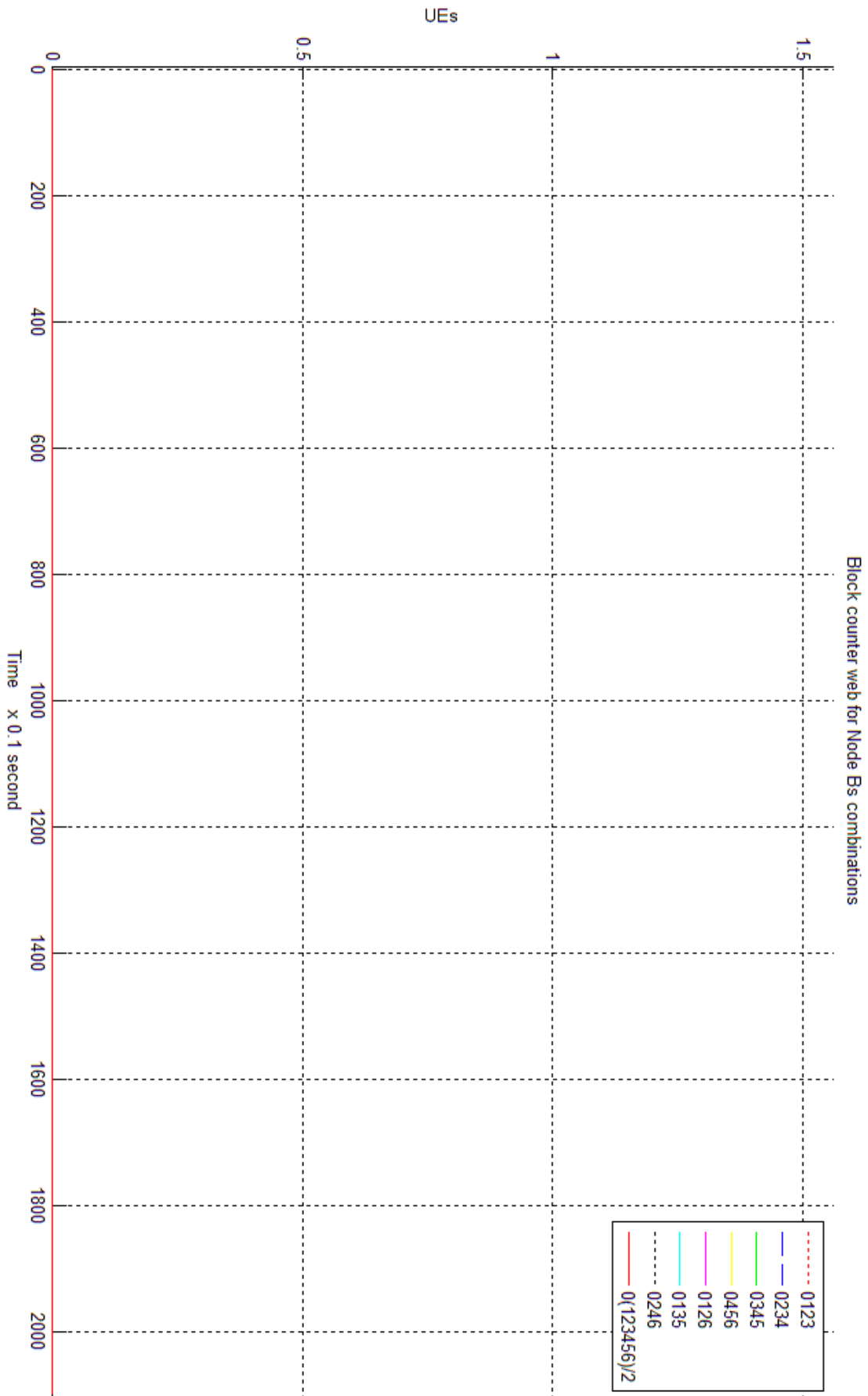

Figure C.33 Web block counter for splitted Node Bs

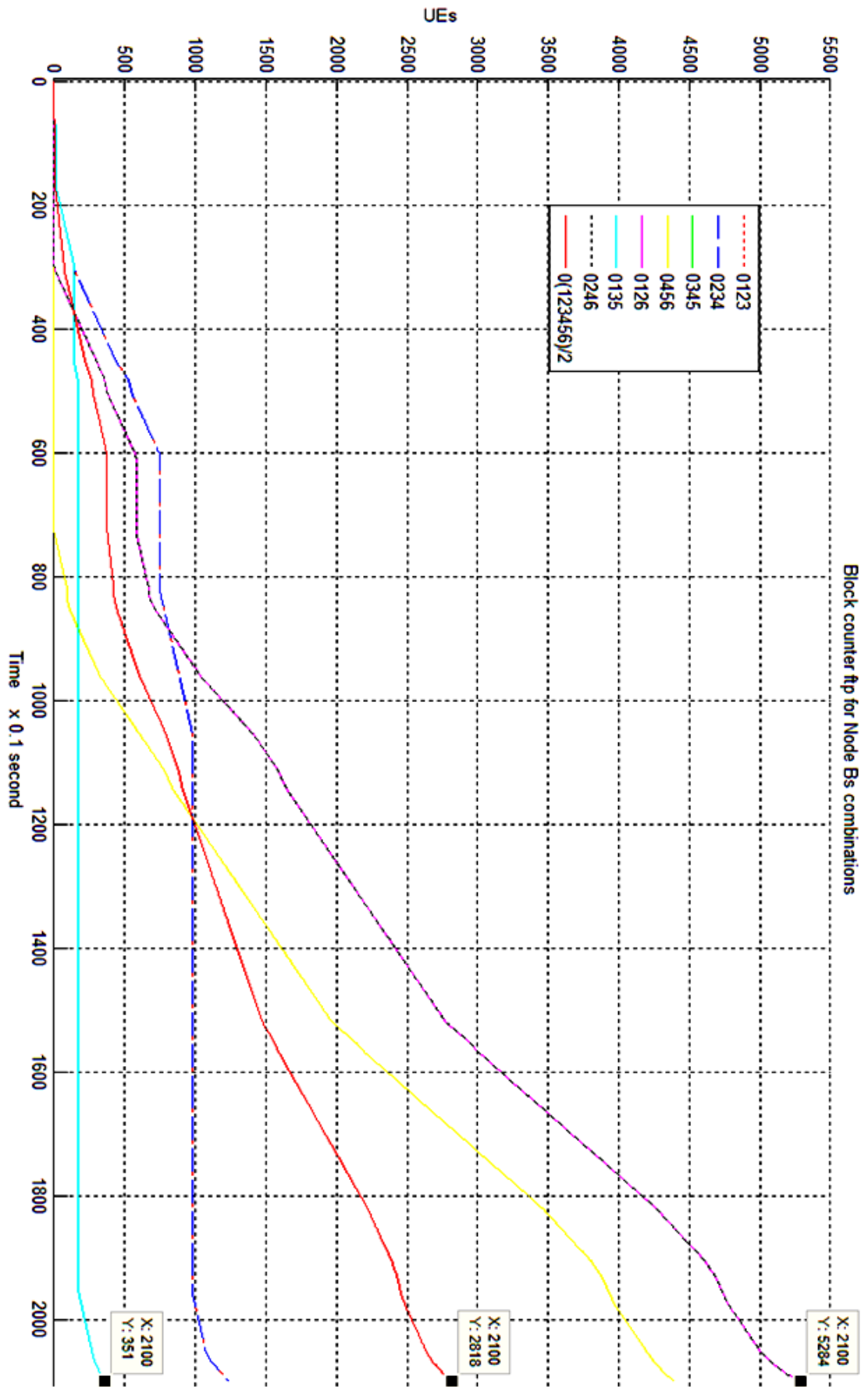

Figure C.34 FTP block counter for splitted Node Bs

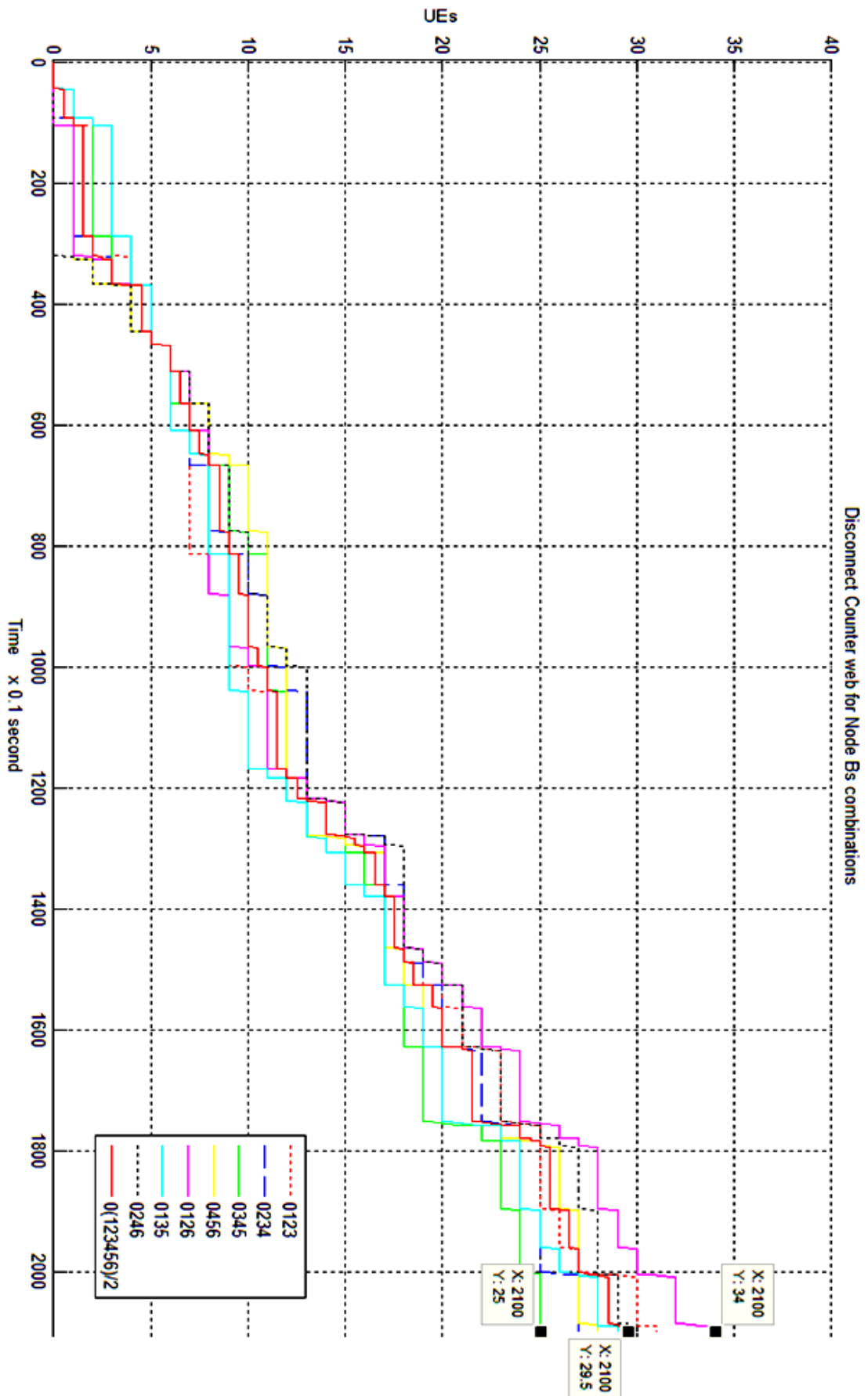

Figure C.35 Web disconnect counter for splitted Node Bs

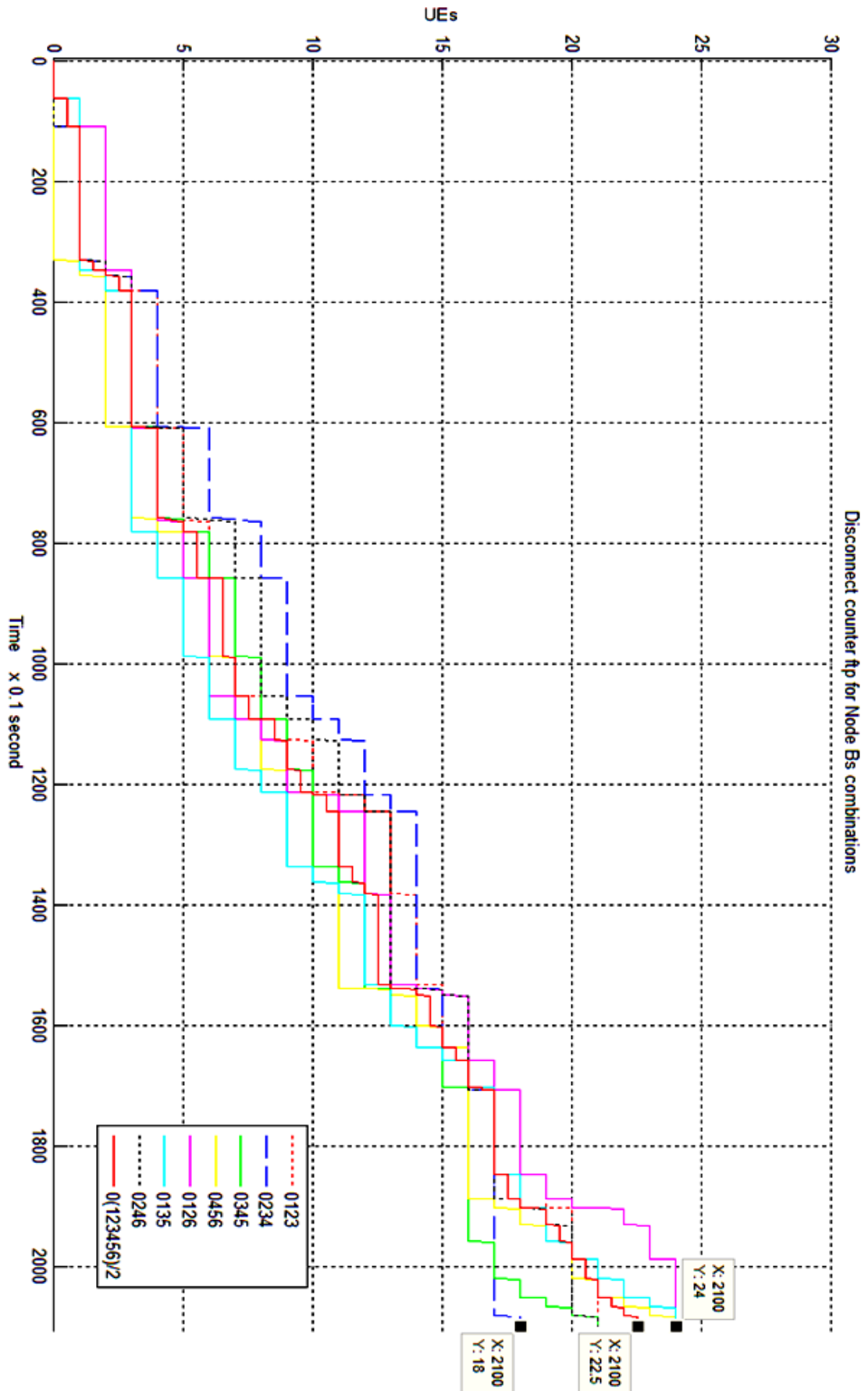

Figure C.36 FTP disconnect counter for splitted Node Bs

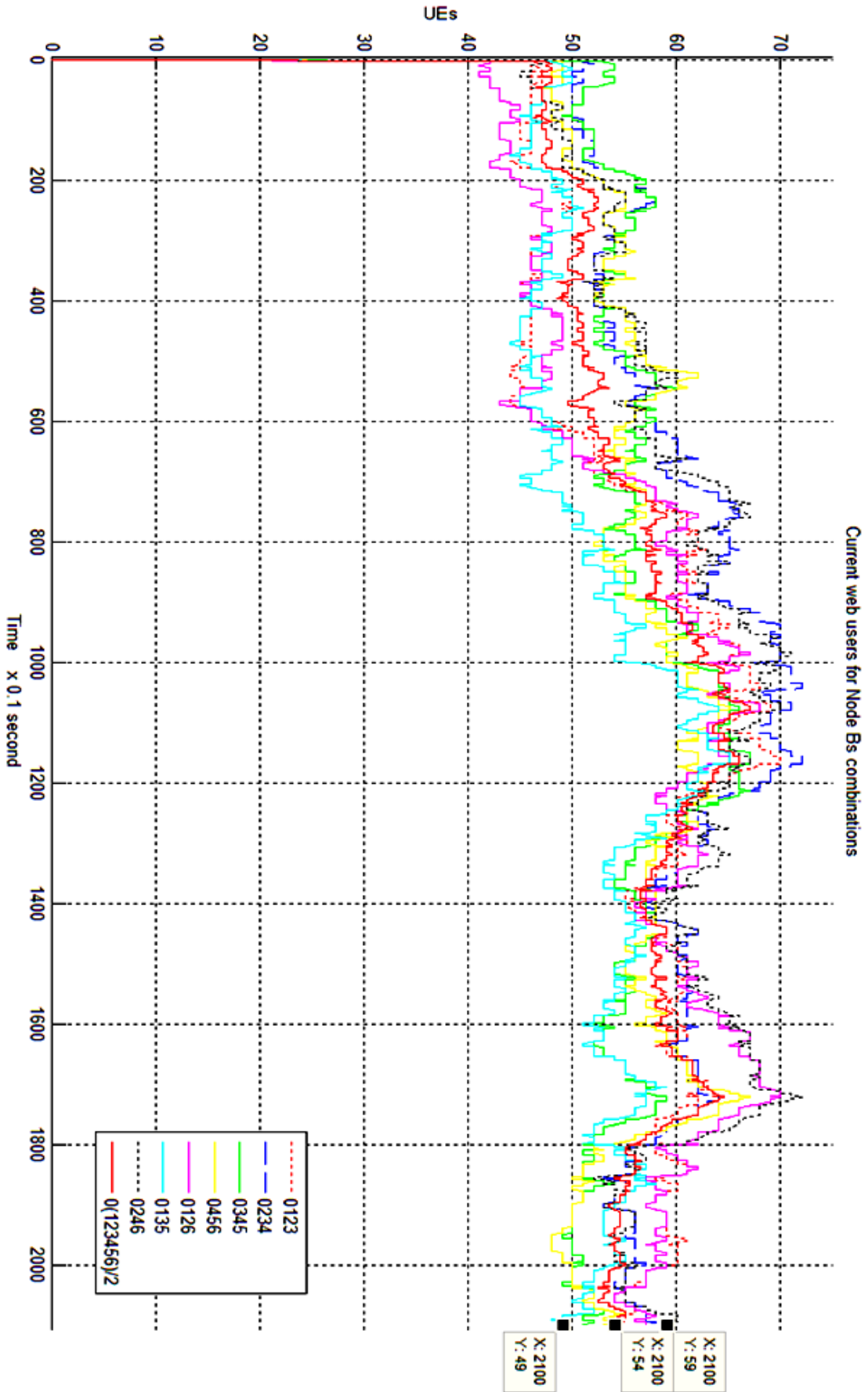

Figure C.37 Current web users for splitted Node Bs

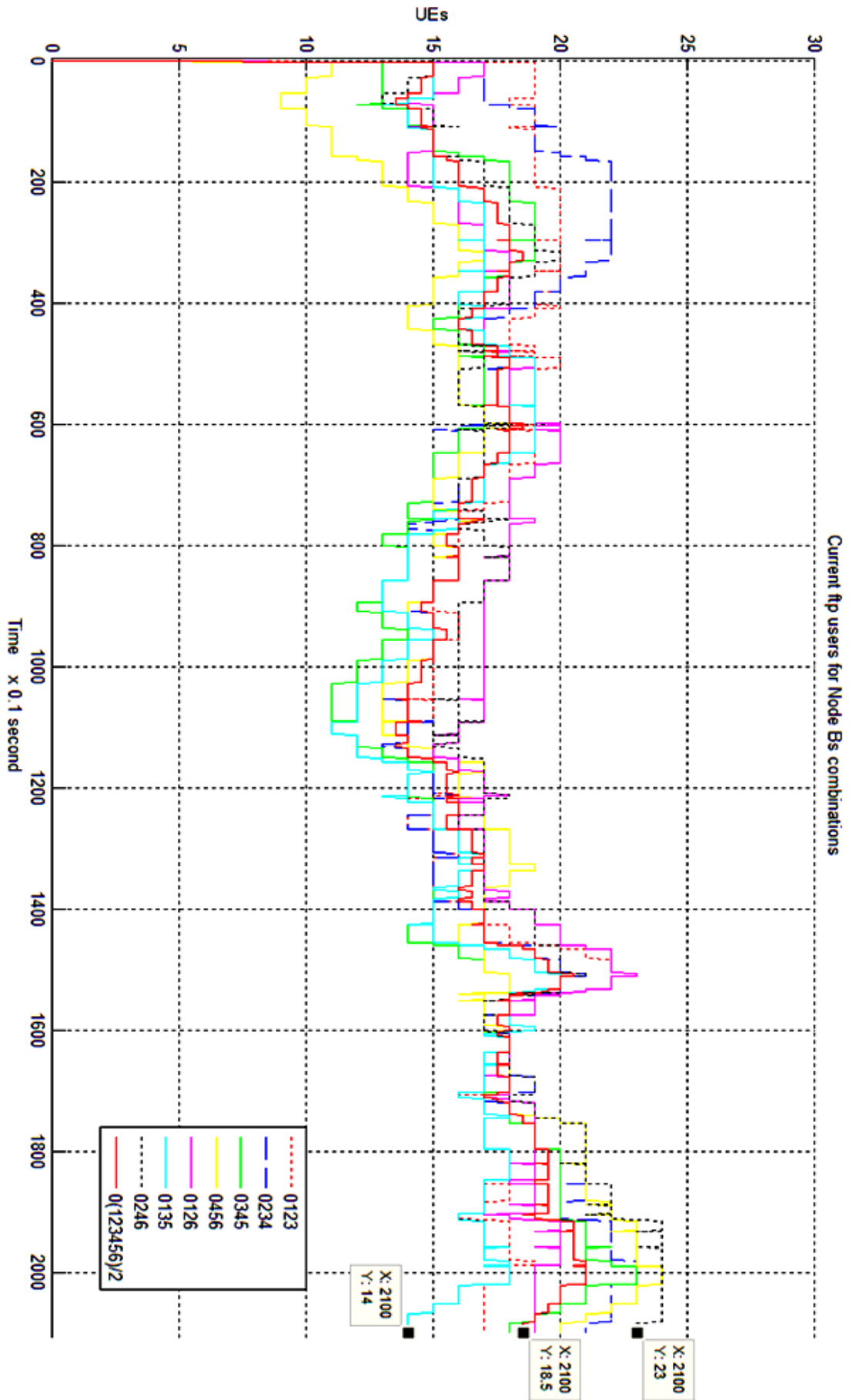

Figure C.38 Current FTP users for splitted Node Bs

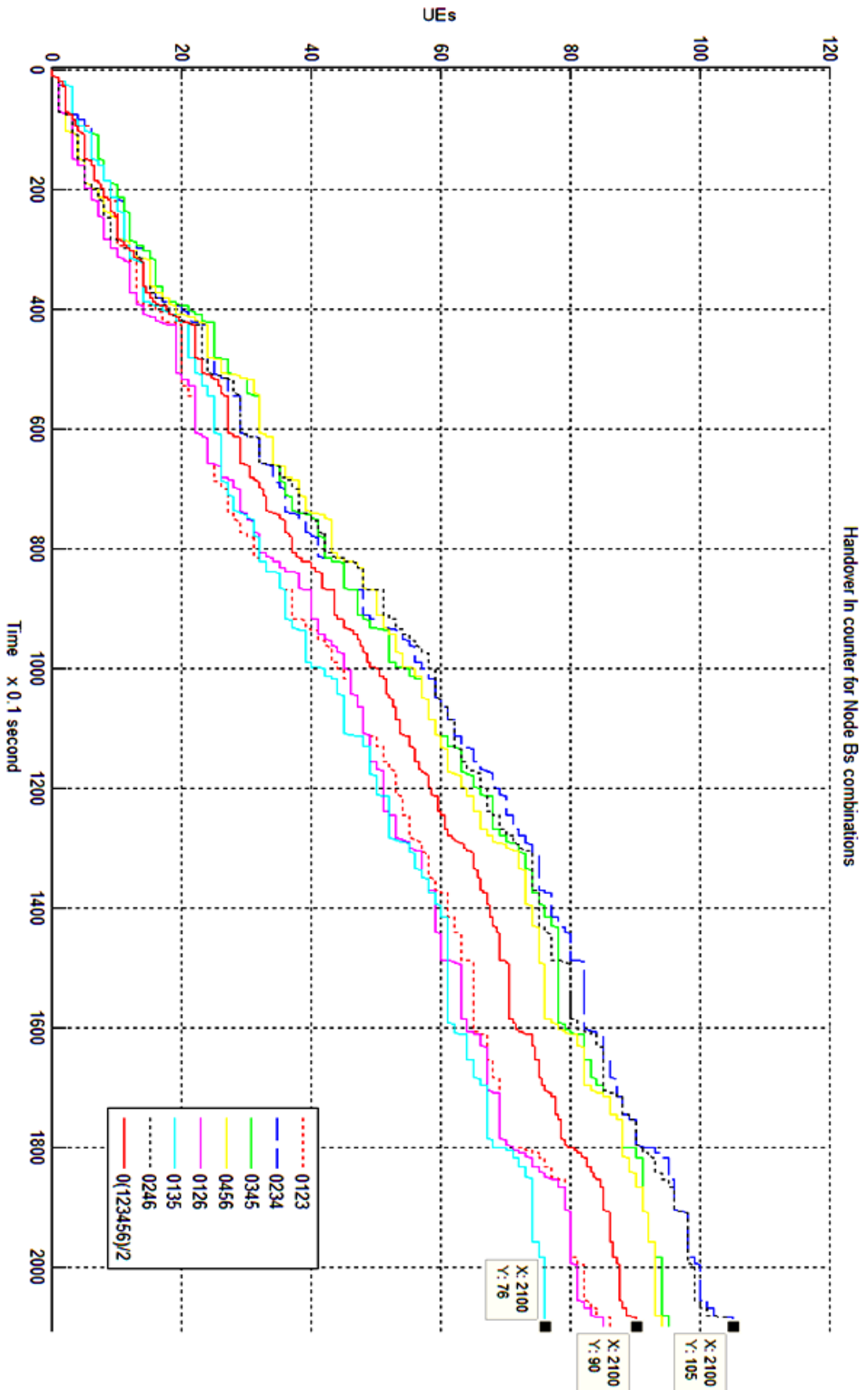

Figure C.39 Handover In for splitted Node Bs

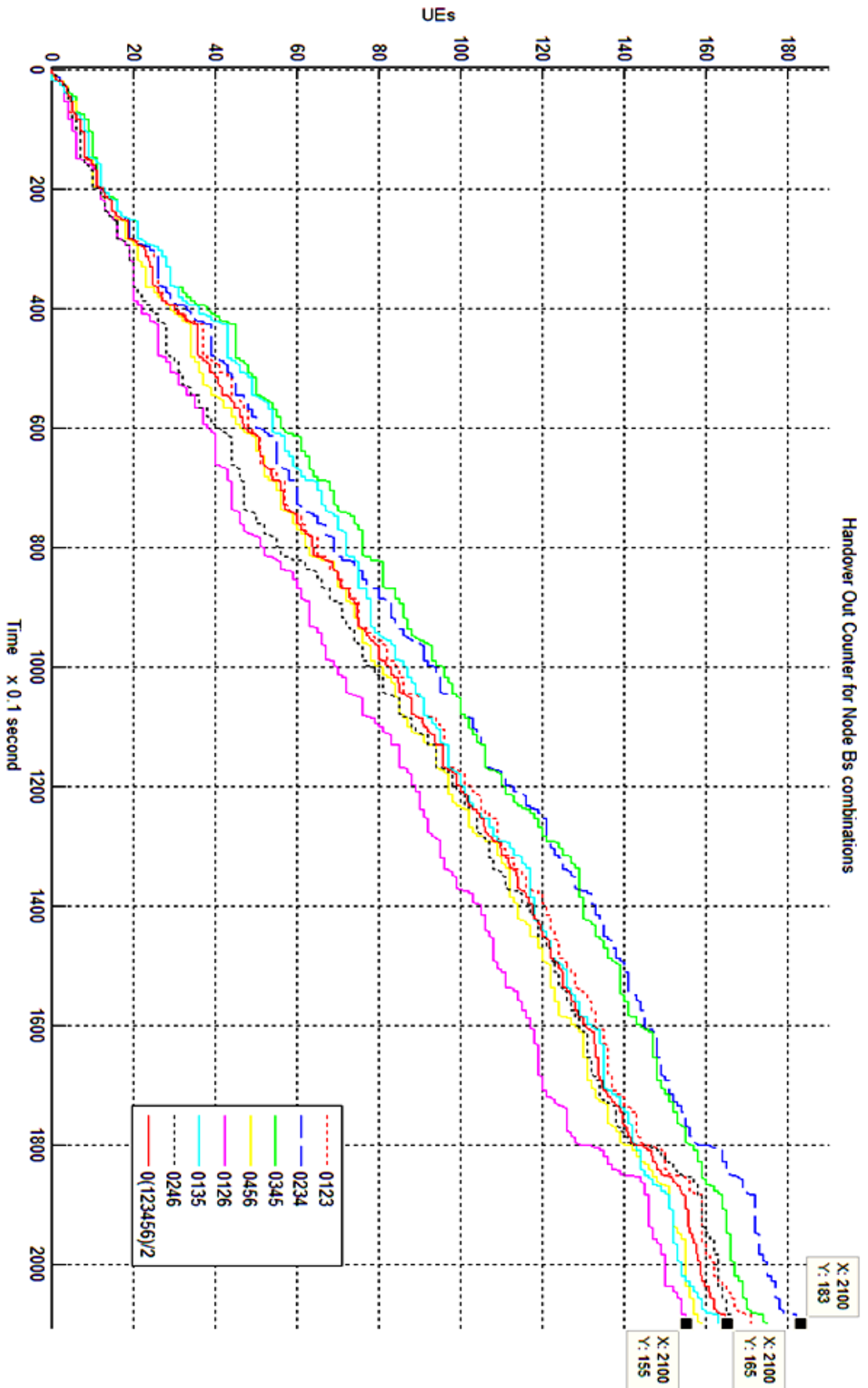

Figure C.40 Handover Out for splitted Node Bs

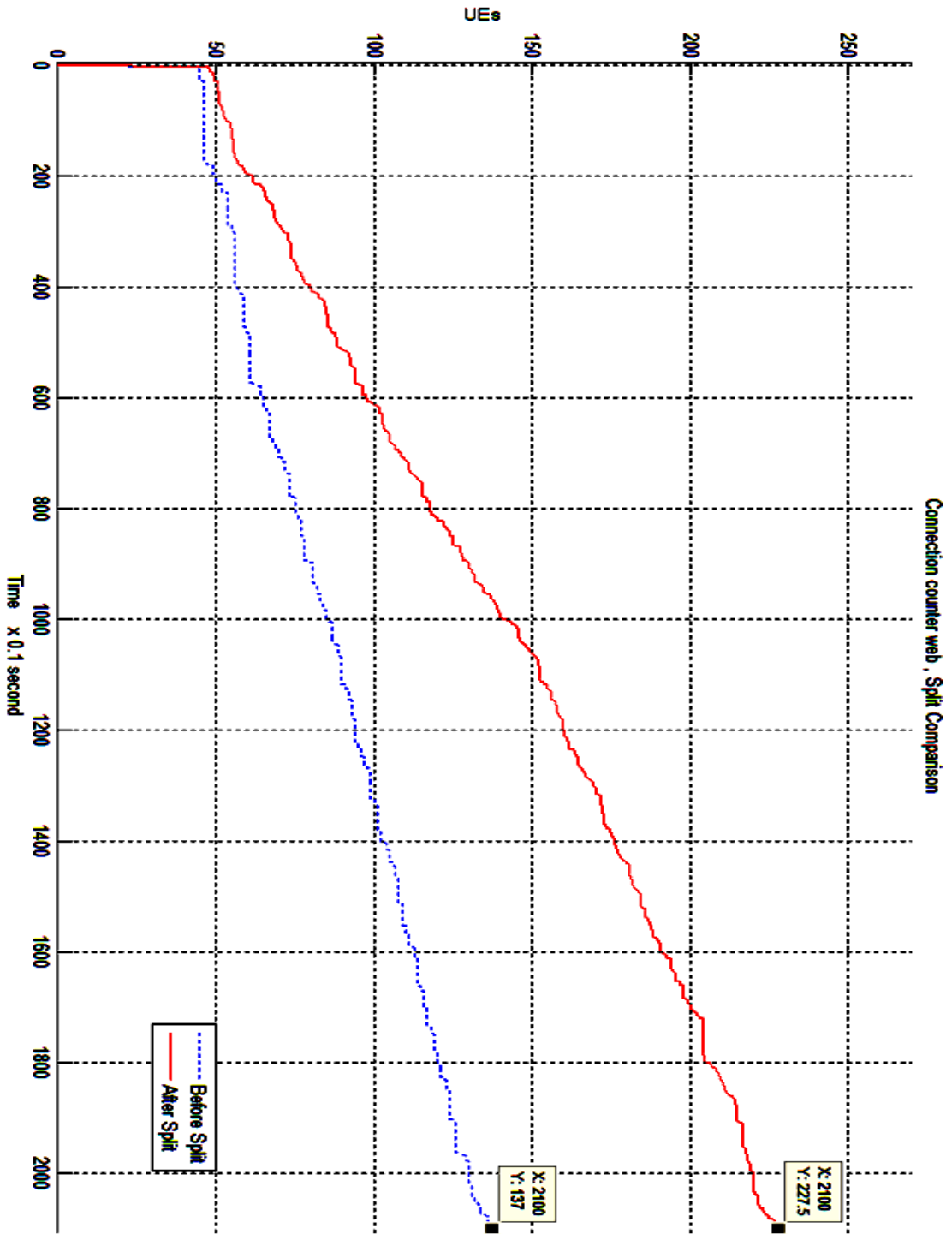

Figure C.41 Web connection counter before and after splitting

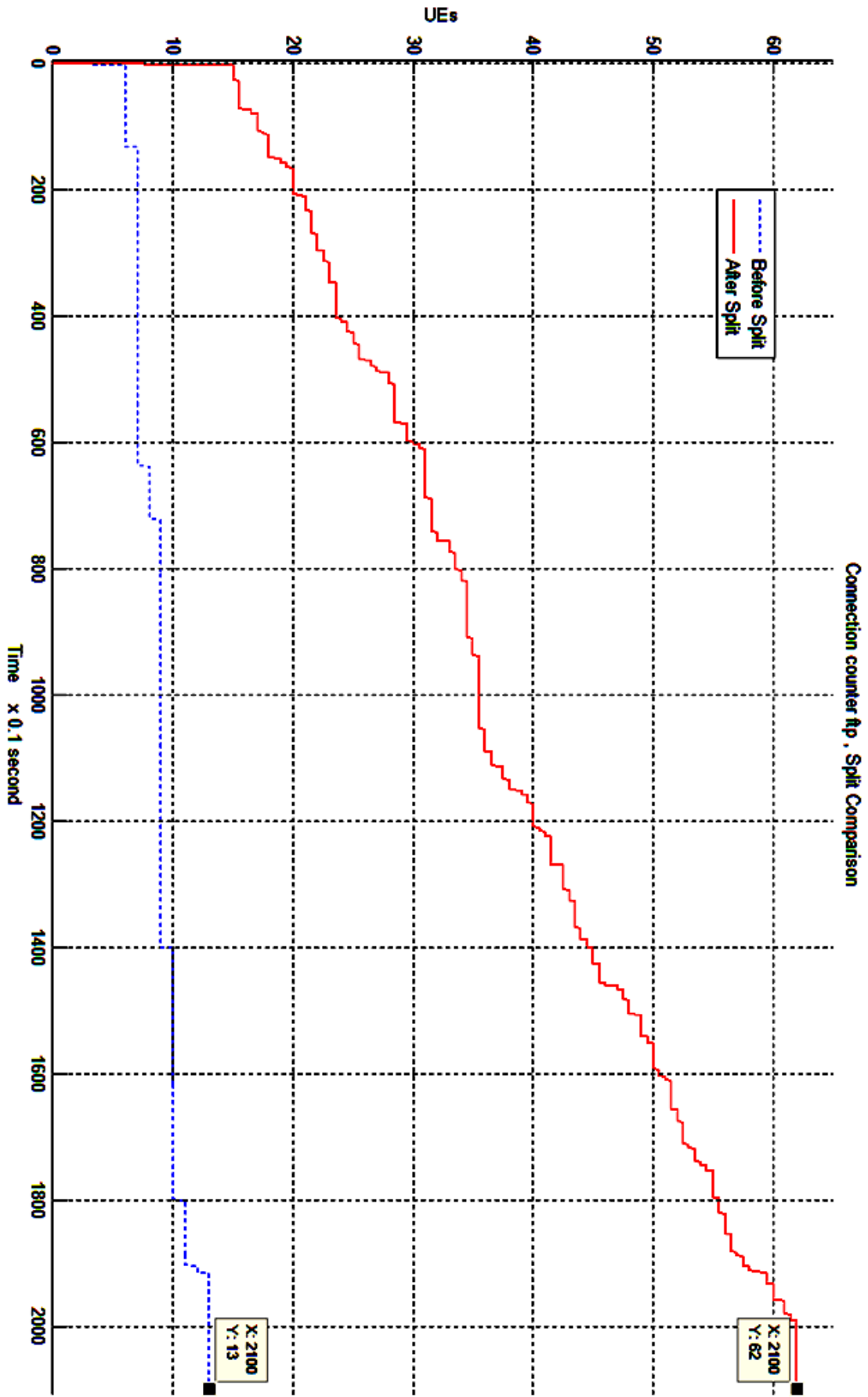

Figure C.42 FTP connection counter before and after splitting

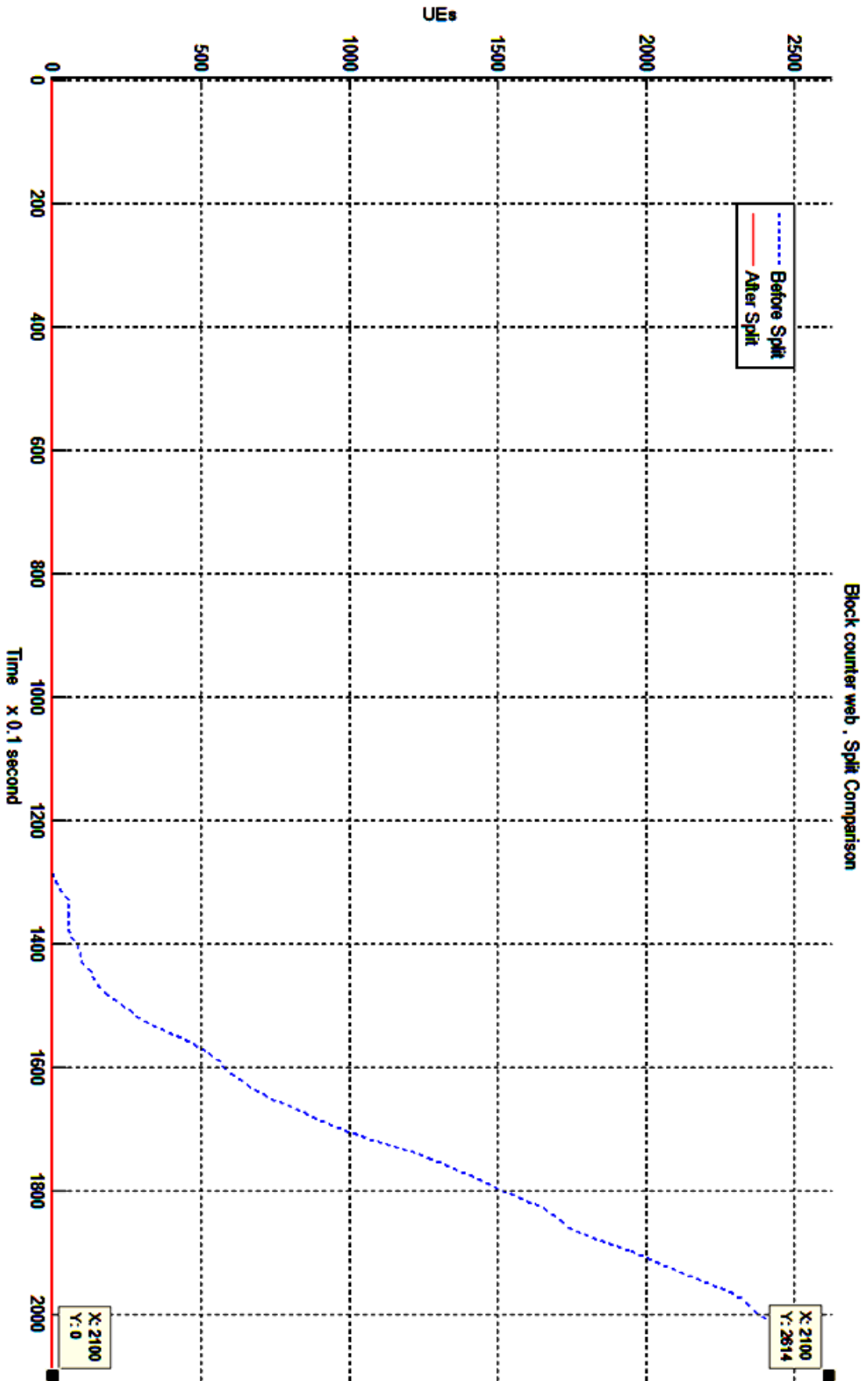

Figure C.43 Web blocking counter before and after splitting

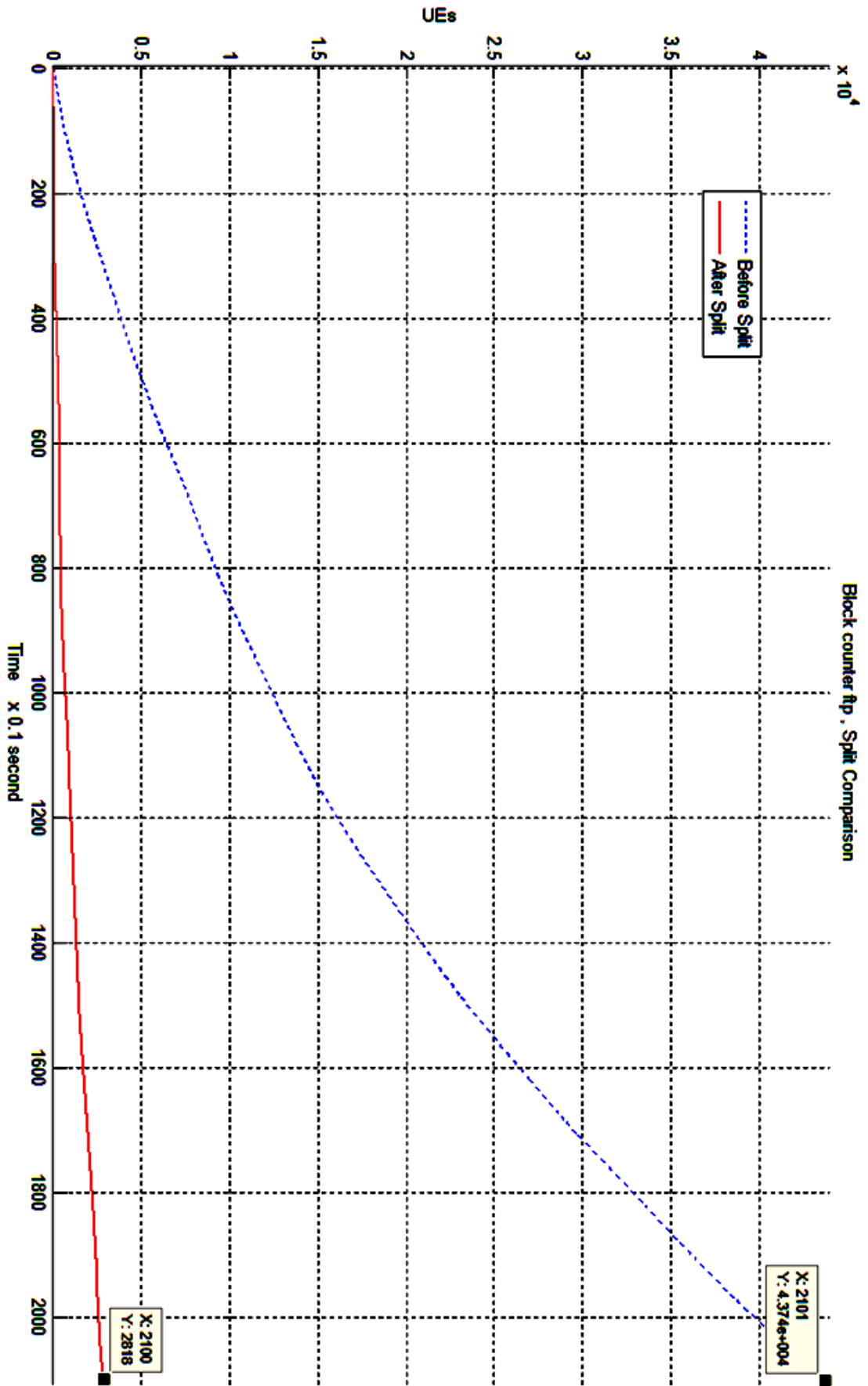

Figure C.44 FTP blocking counter before and after splitting

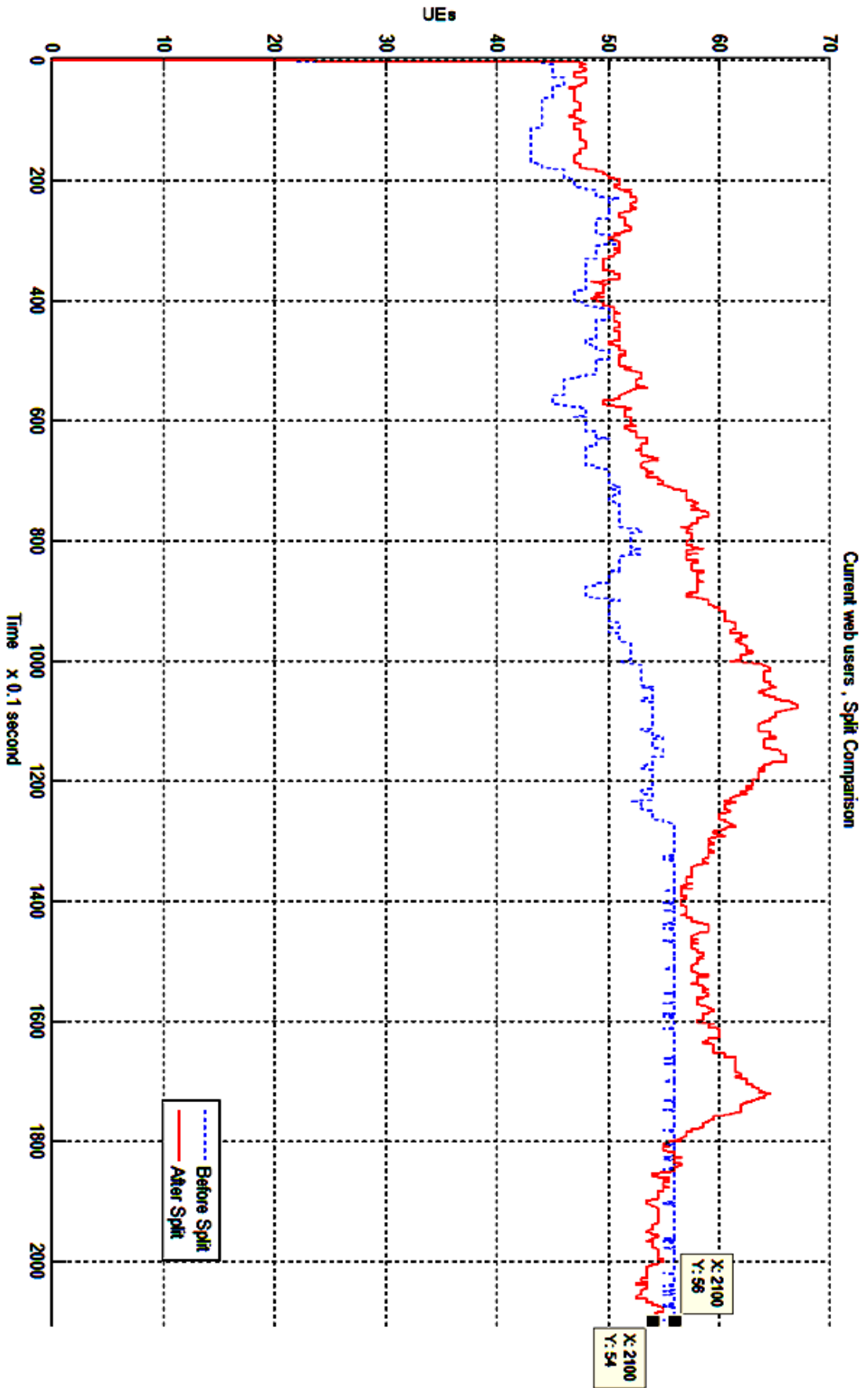

Figure C.45 Current web users before and after splitting

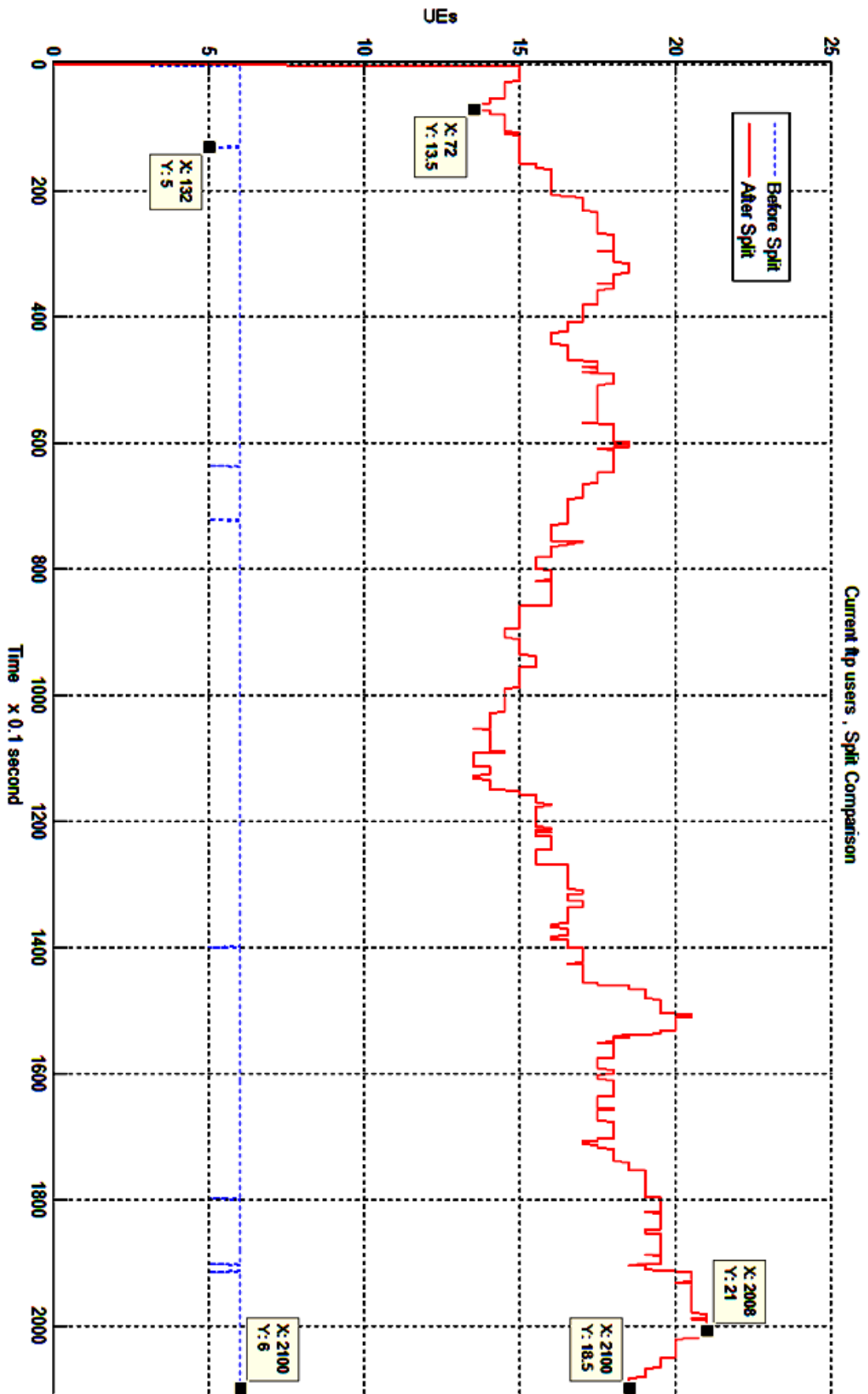

Figure C.46 Current FTP users before and after splitting

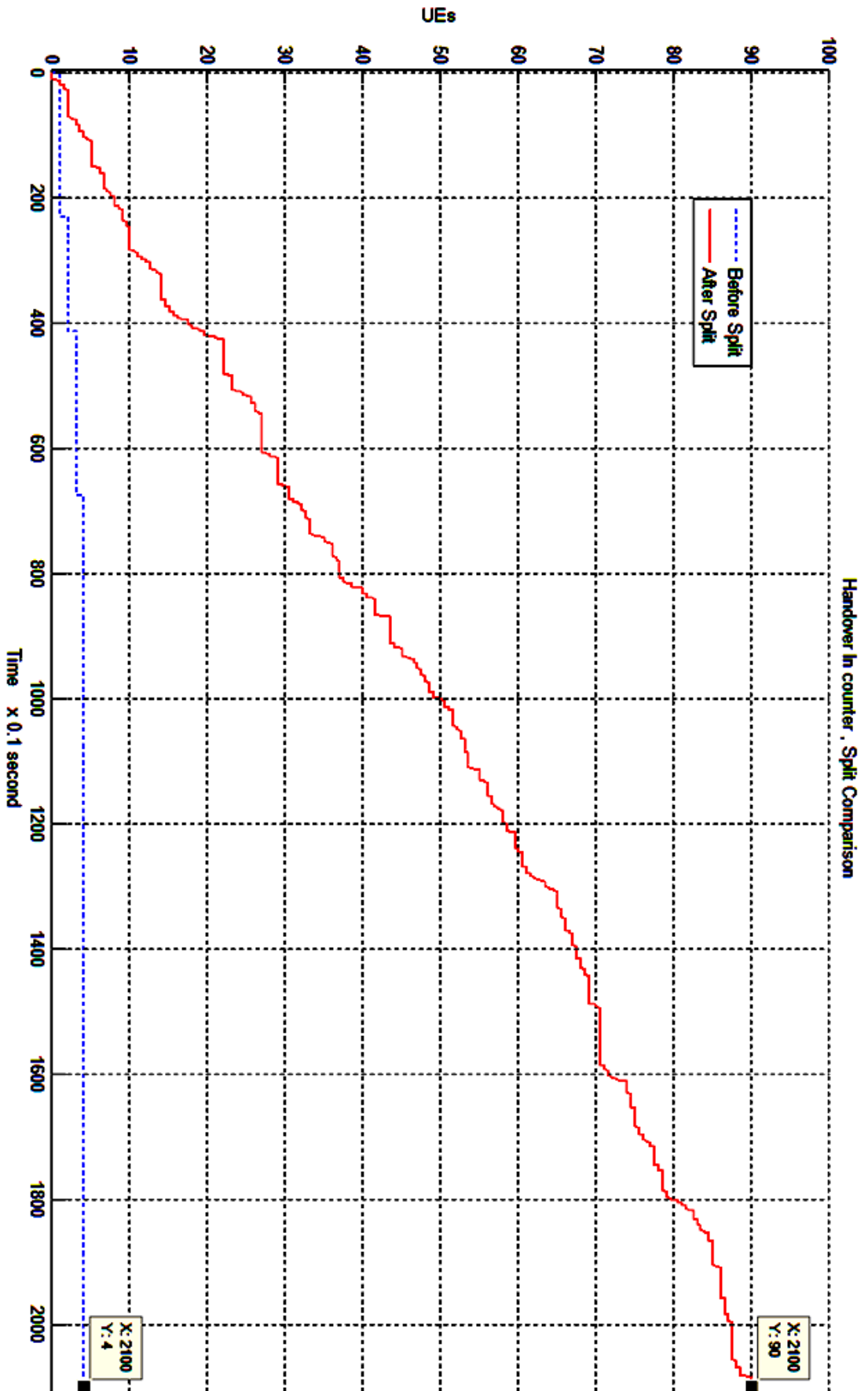

Figure C.47 Handover In before and after splitting

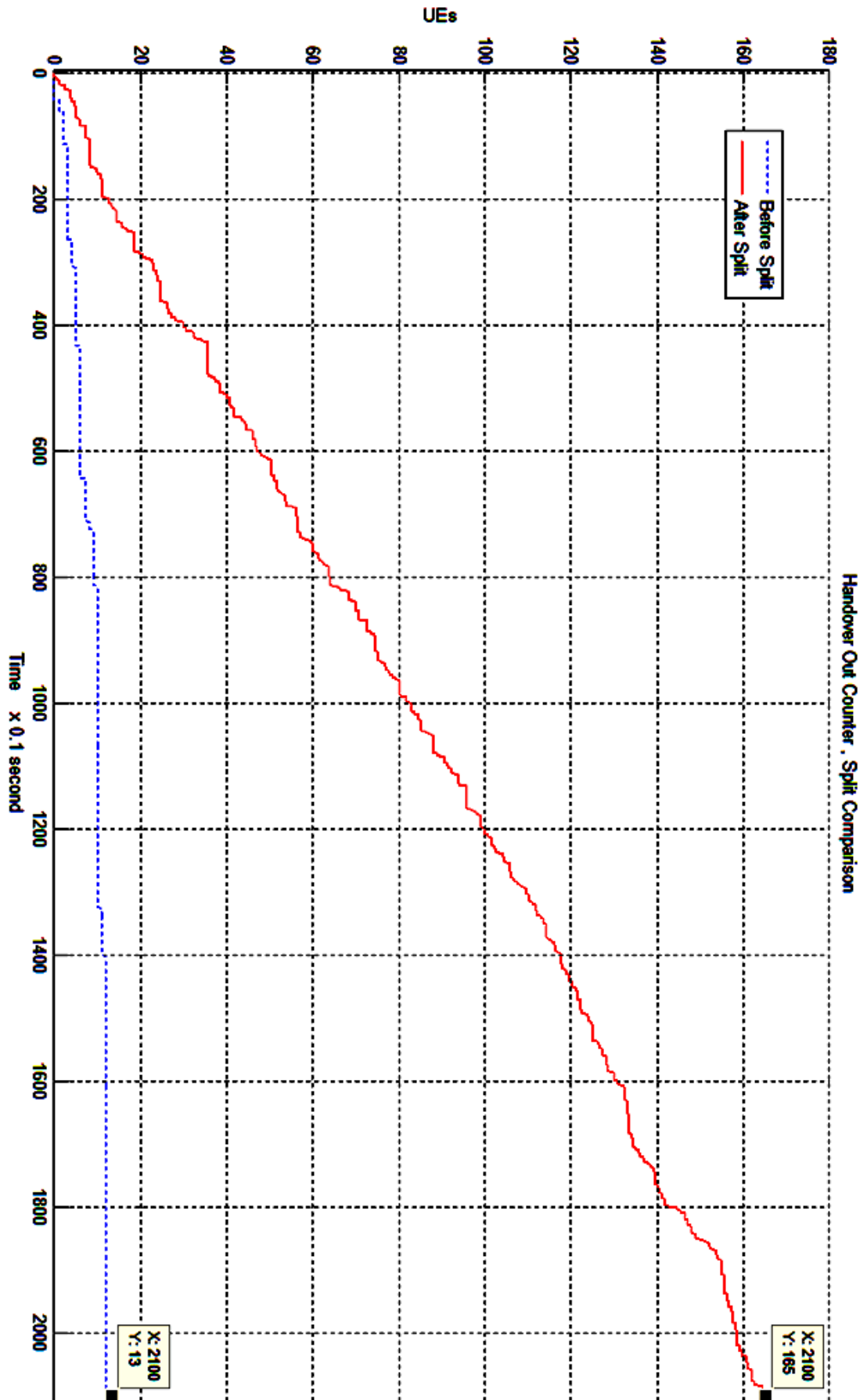

Figure C.48 Handover Out before and after splitting

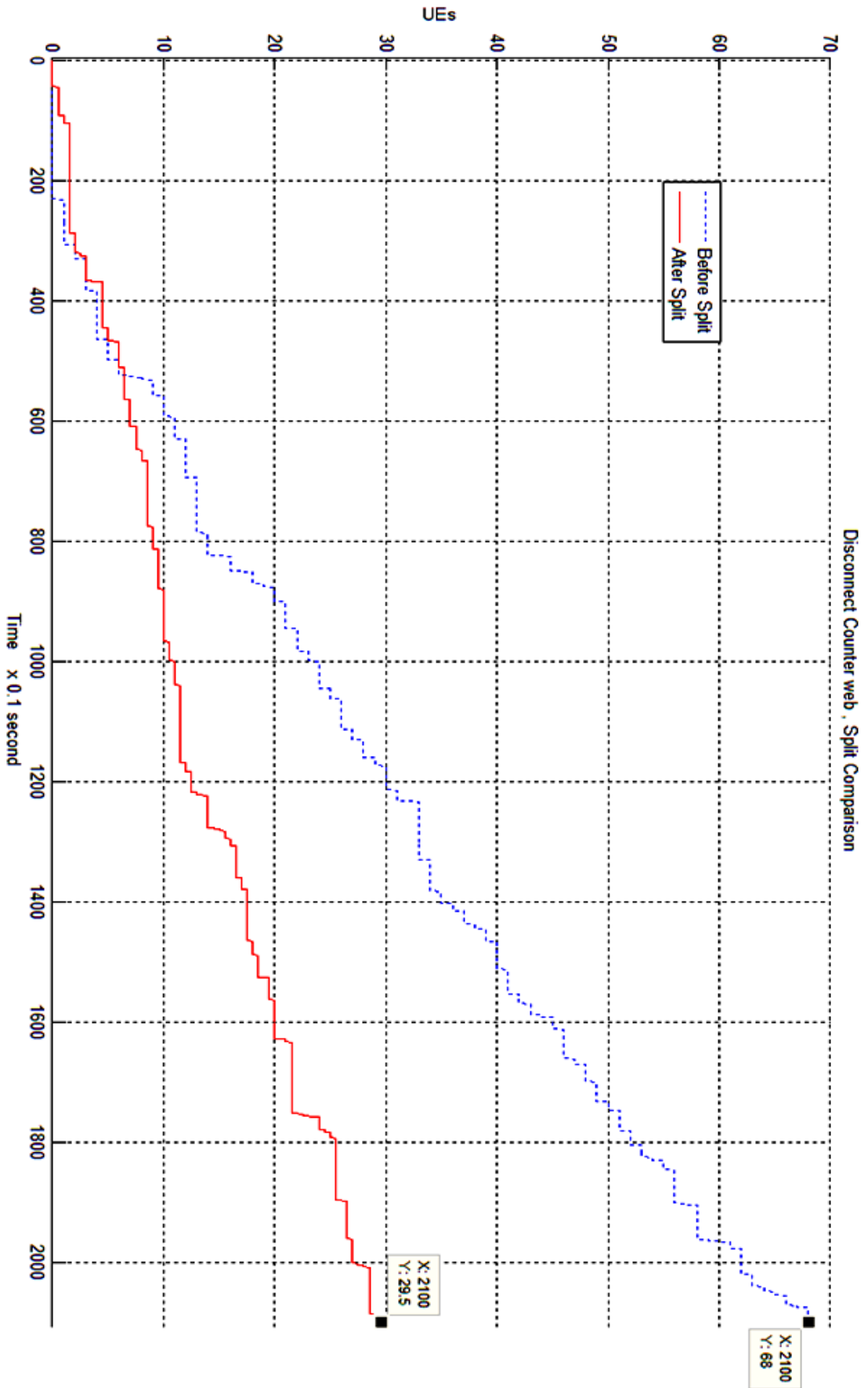

Figure C.49 Web Disconnect counter before and after splitting

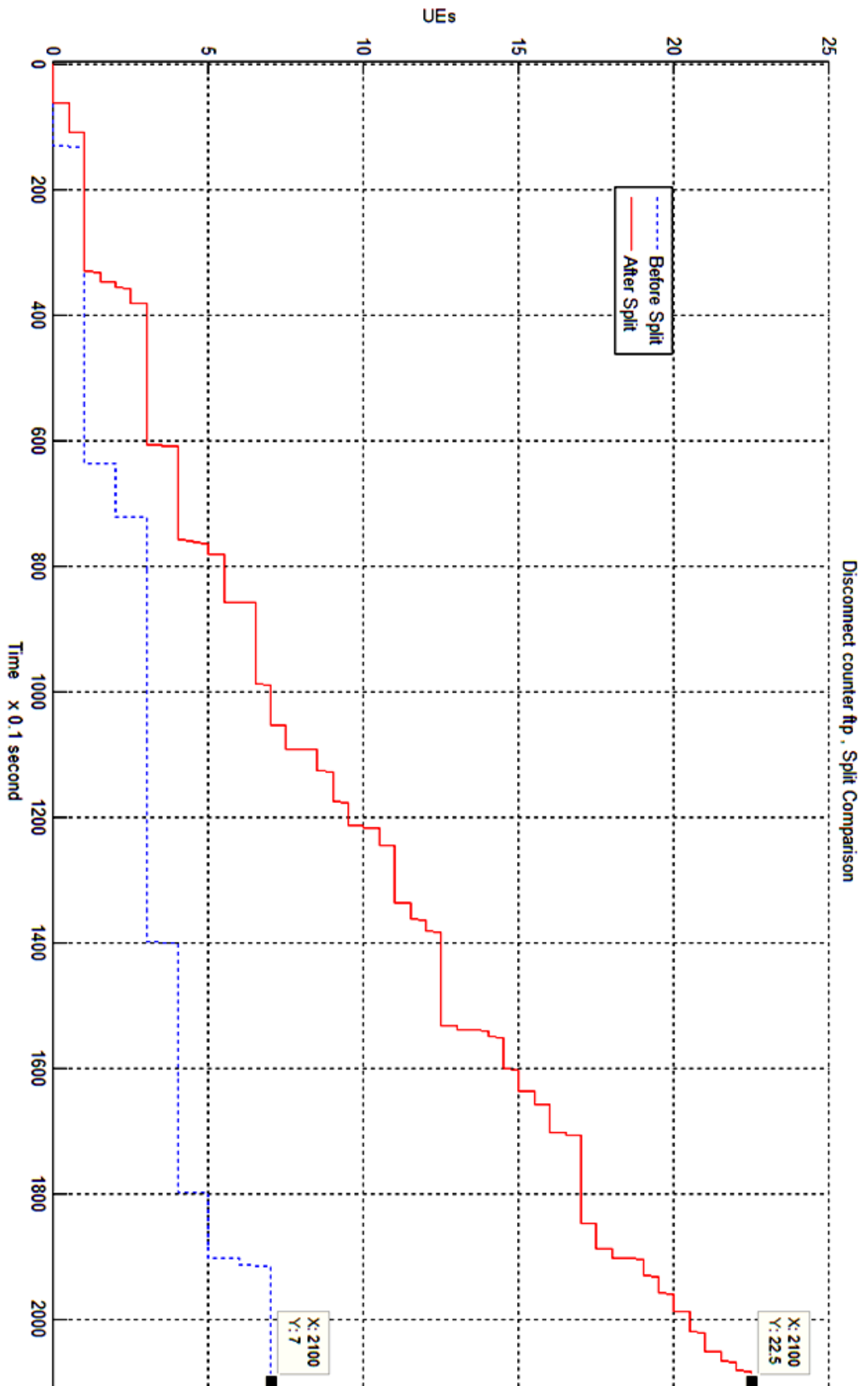

Figure C.50 FTP Disconnect counter before and after splitting

4.3.1 Results of individual sectors

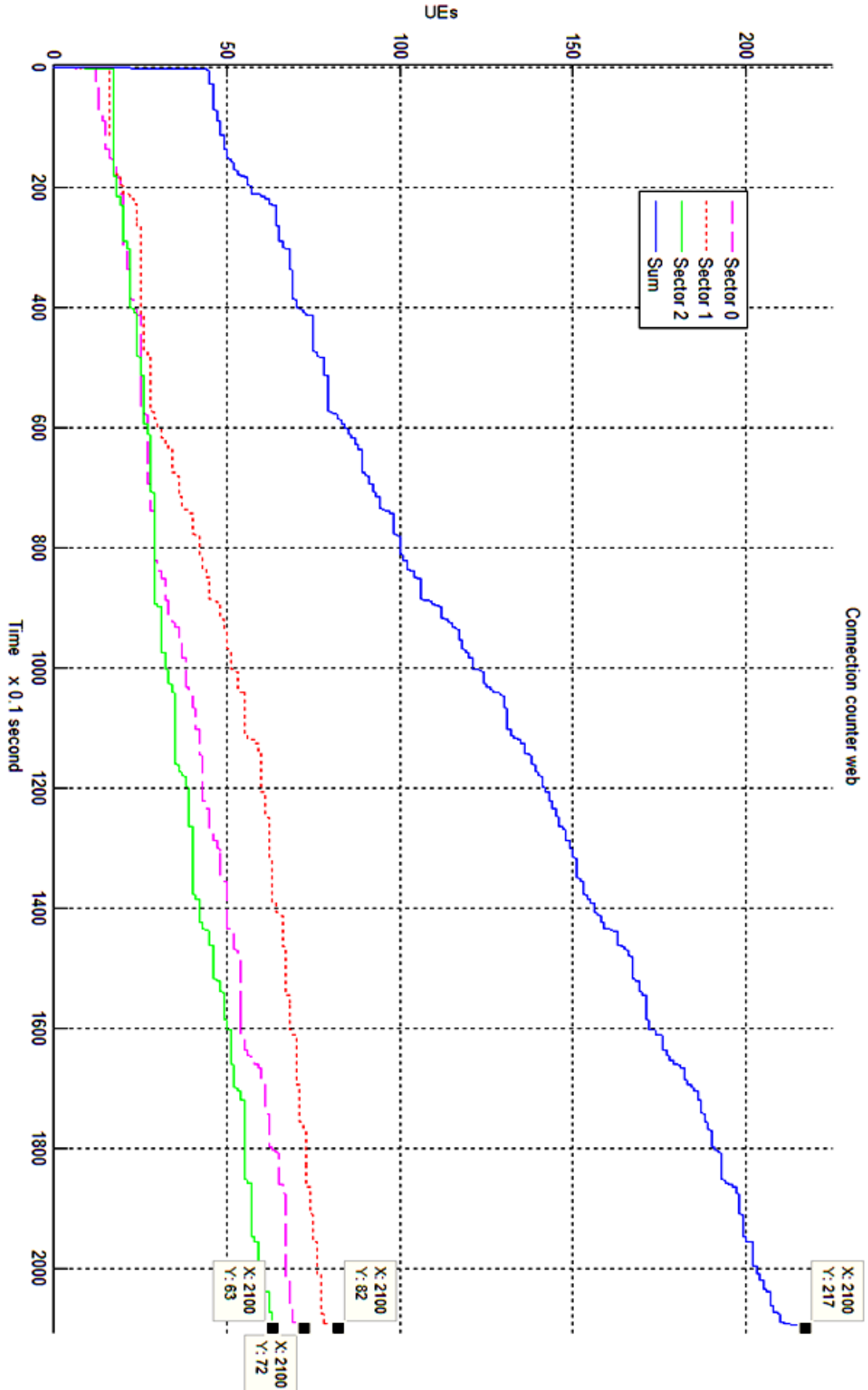

Figure C.51 Web connection counter for sectors

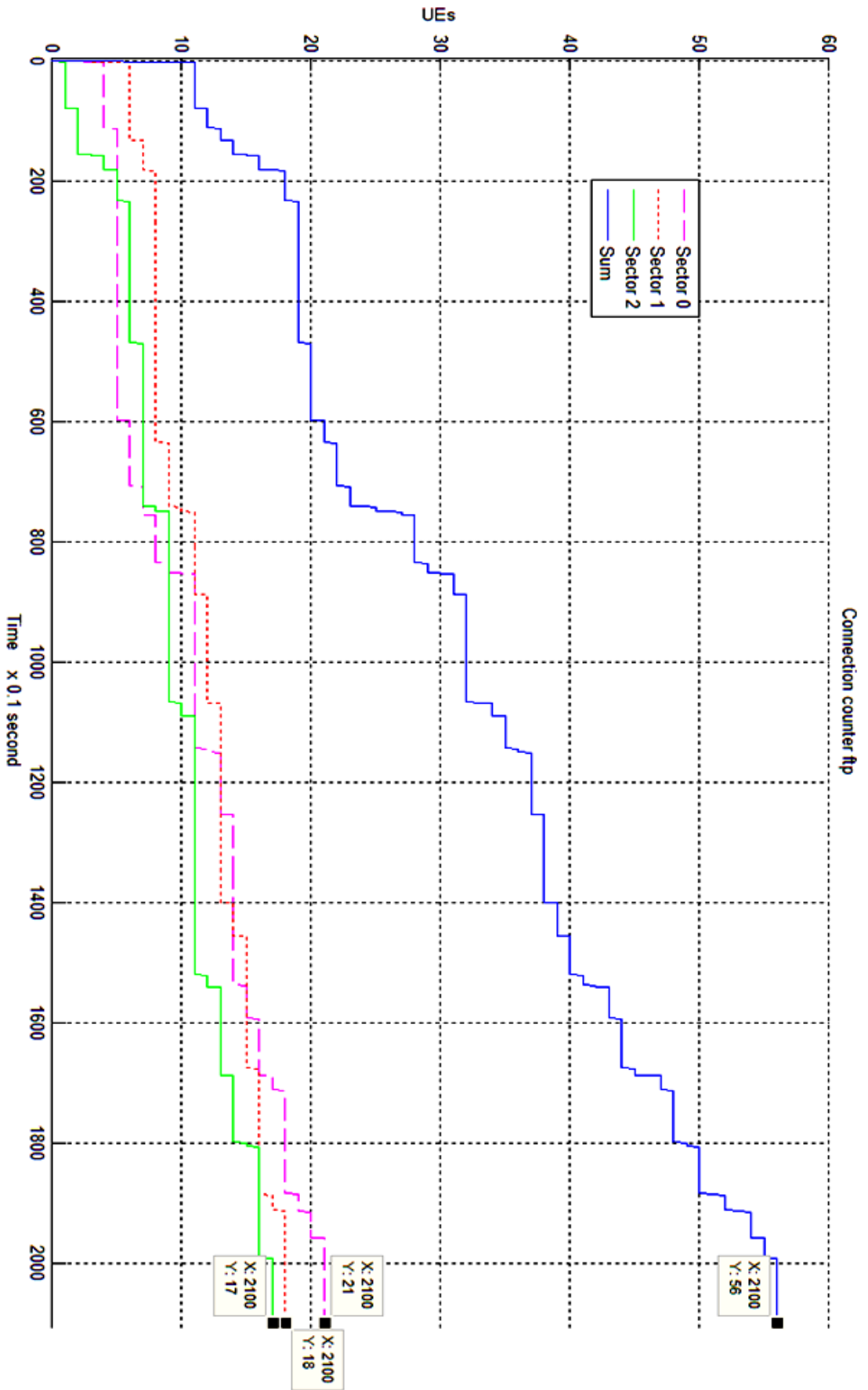

Figure C.52 FTP connection counter for sectors

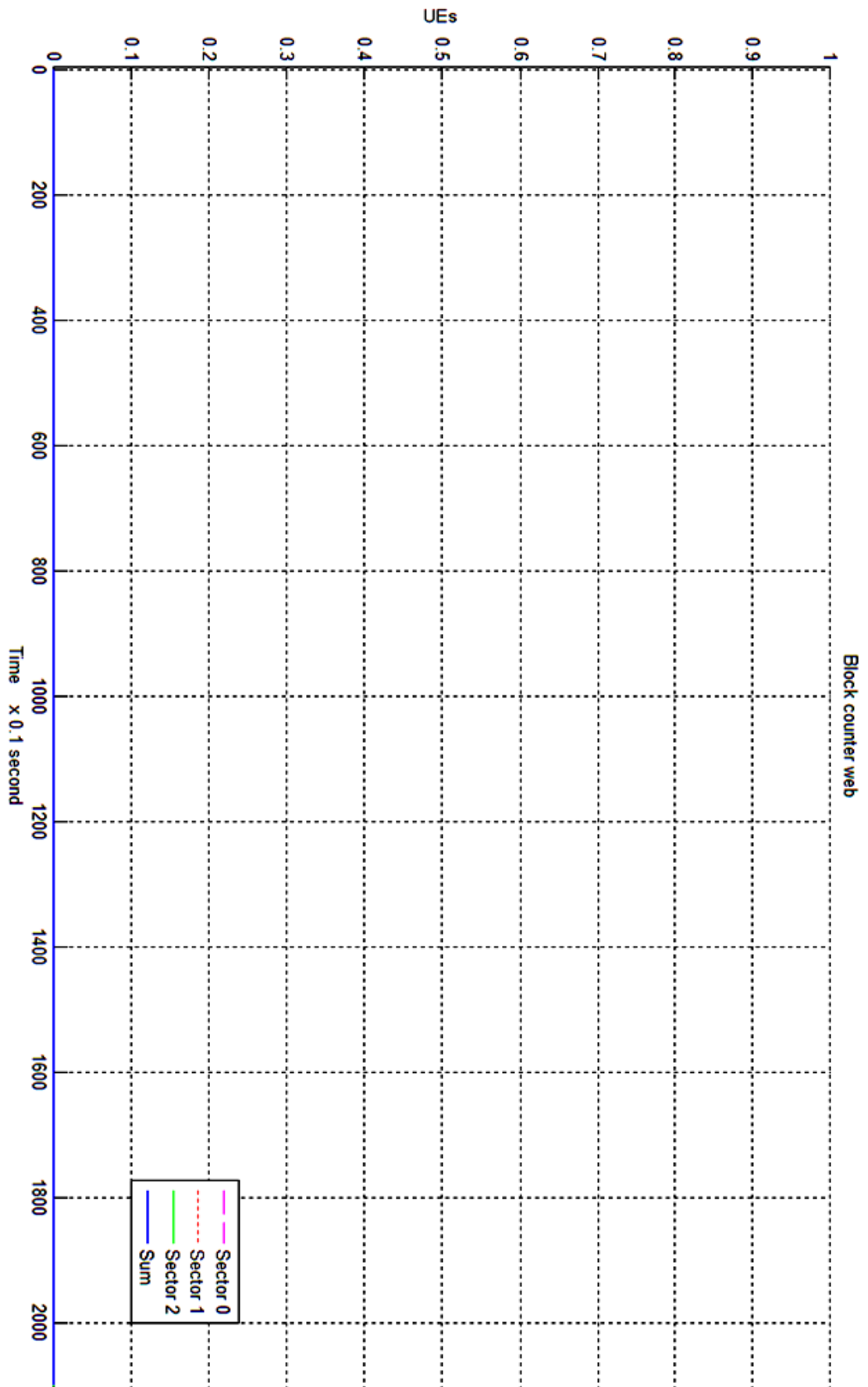

Figure C.53 Web block counter for sectors

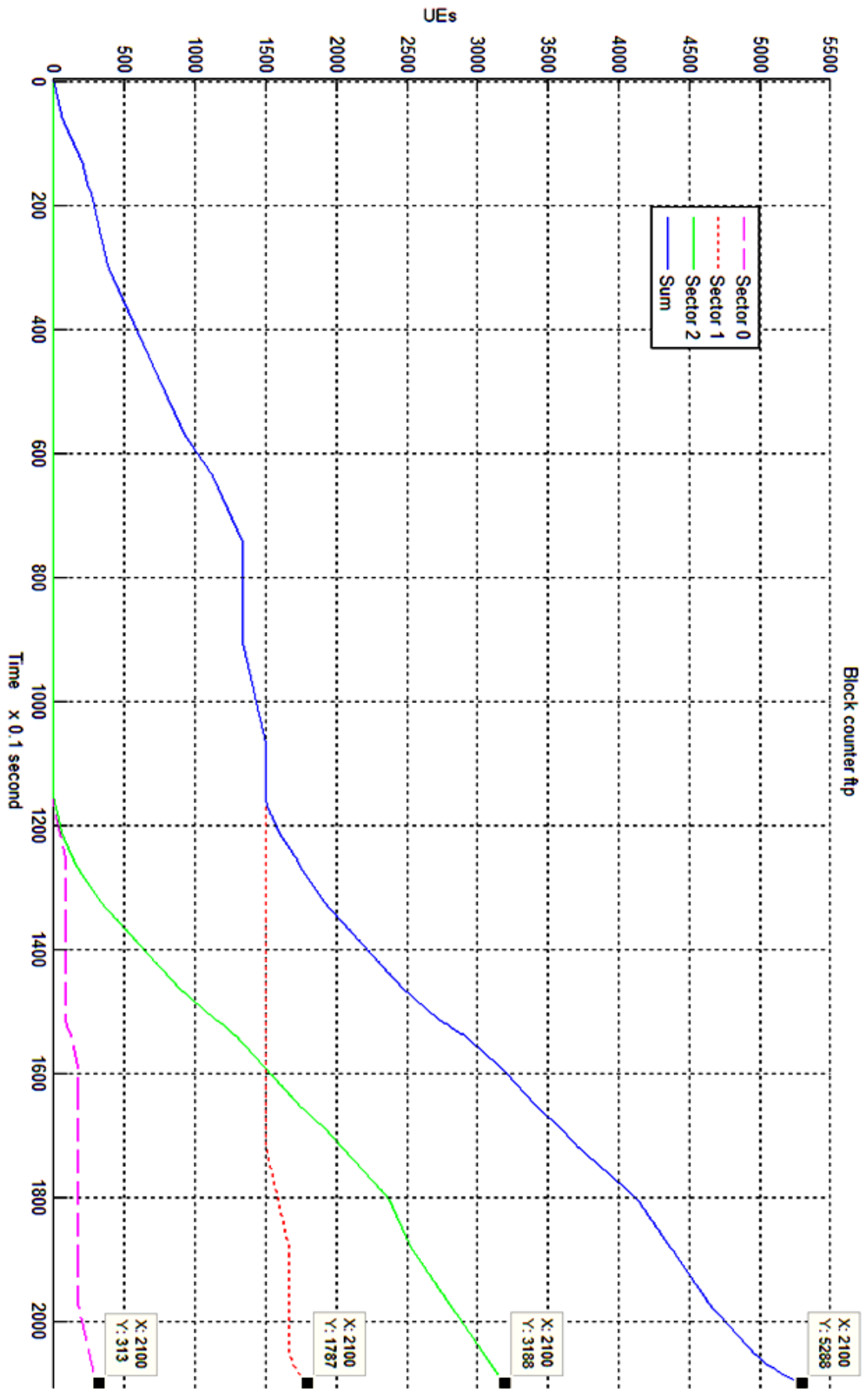

Figure C.54 FTP block counter for sectors

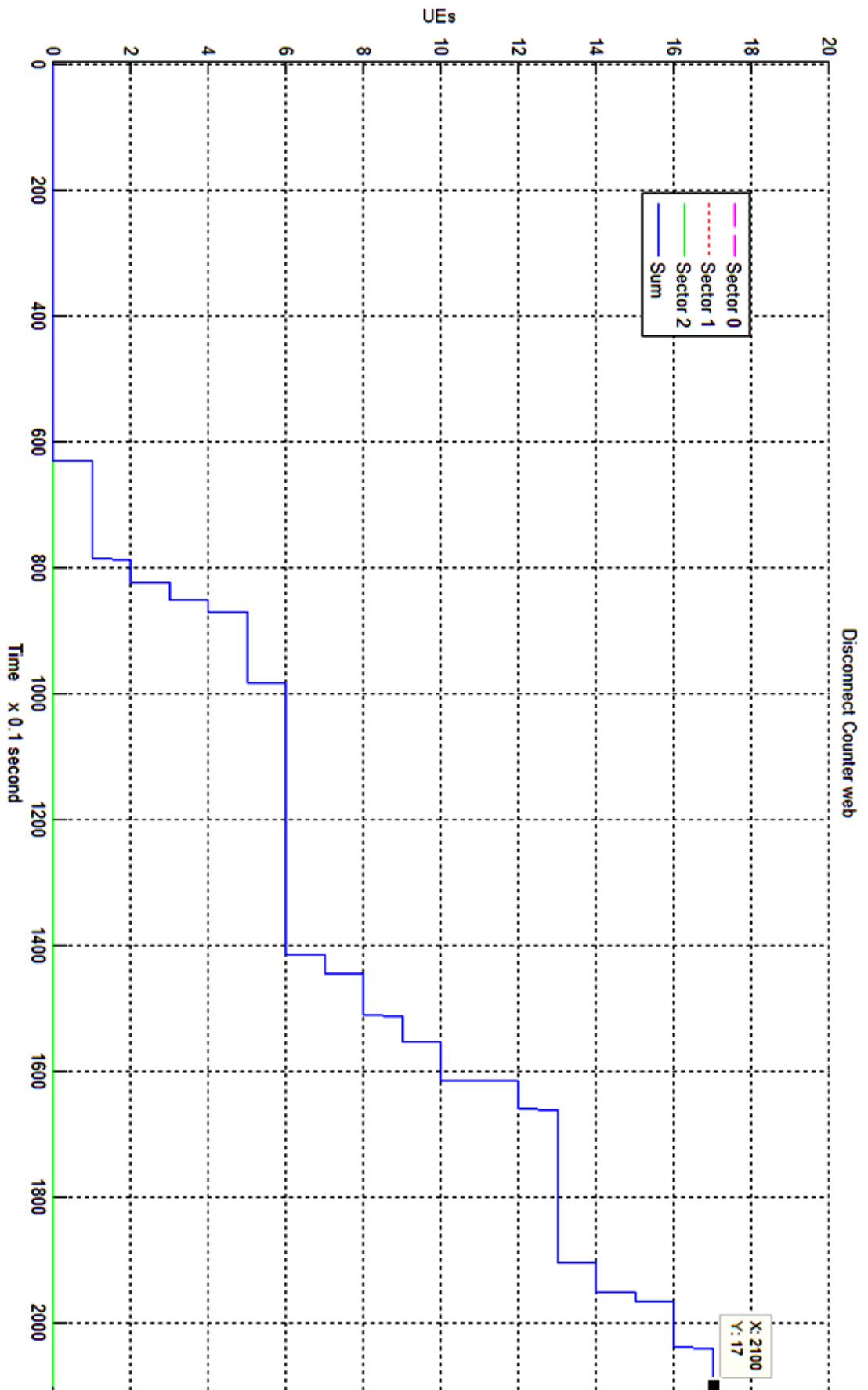

Figure C.55 Web disconnect counter for sectors

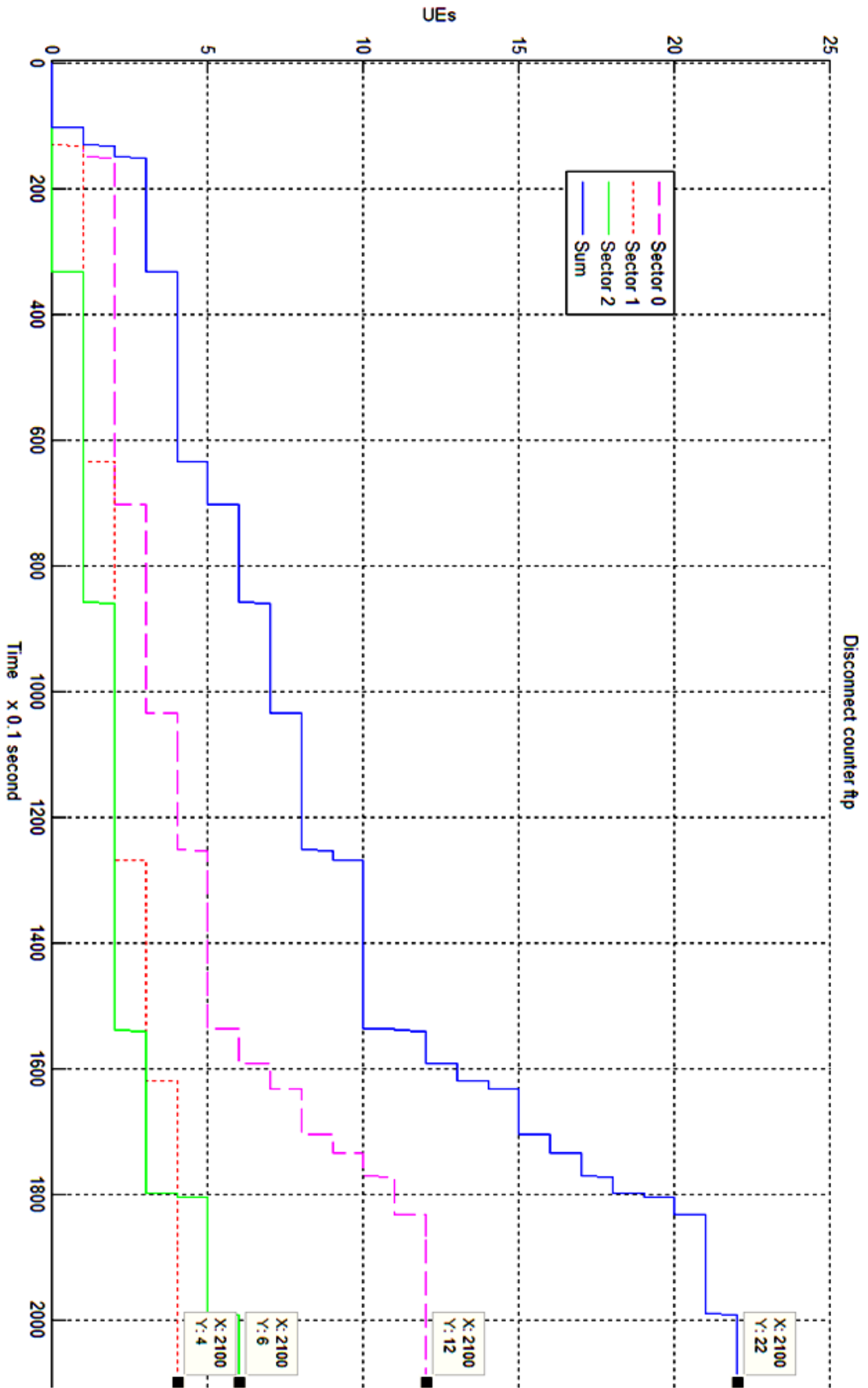

Figure C.56 FTP disconnect counter for sectors

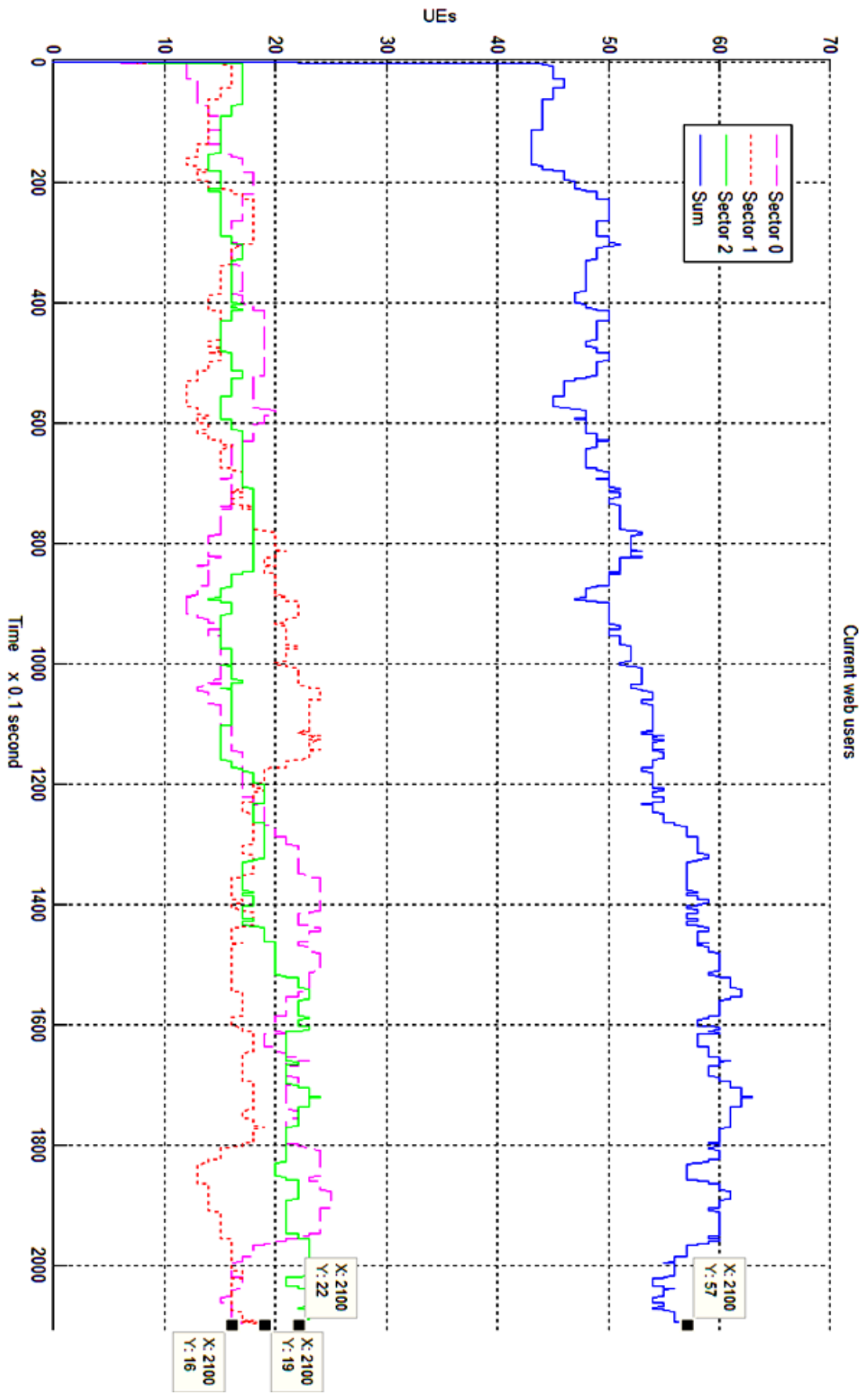

Figure C.57 Current web users for sectors

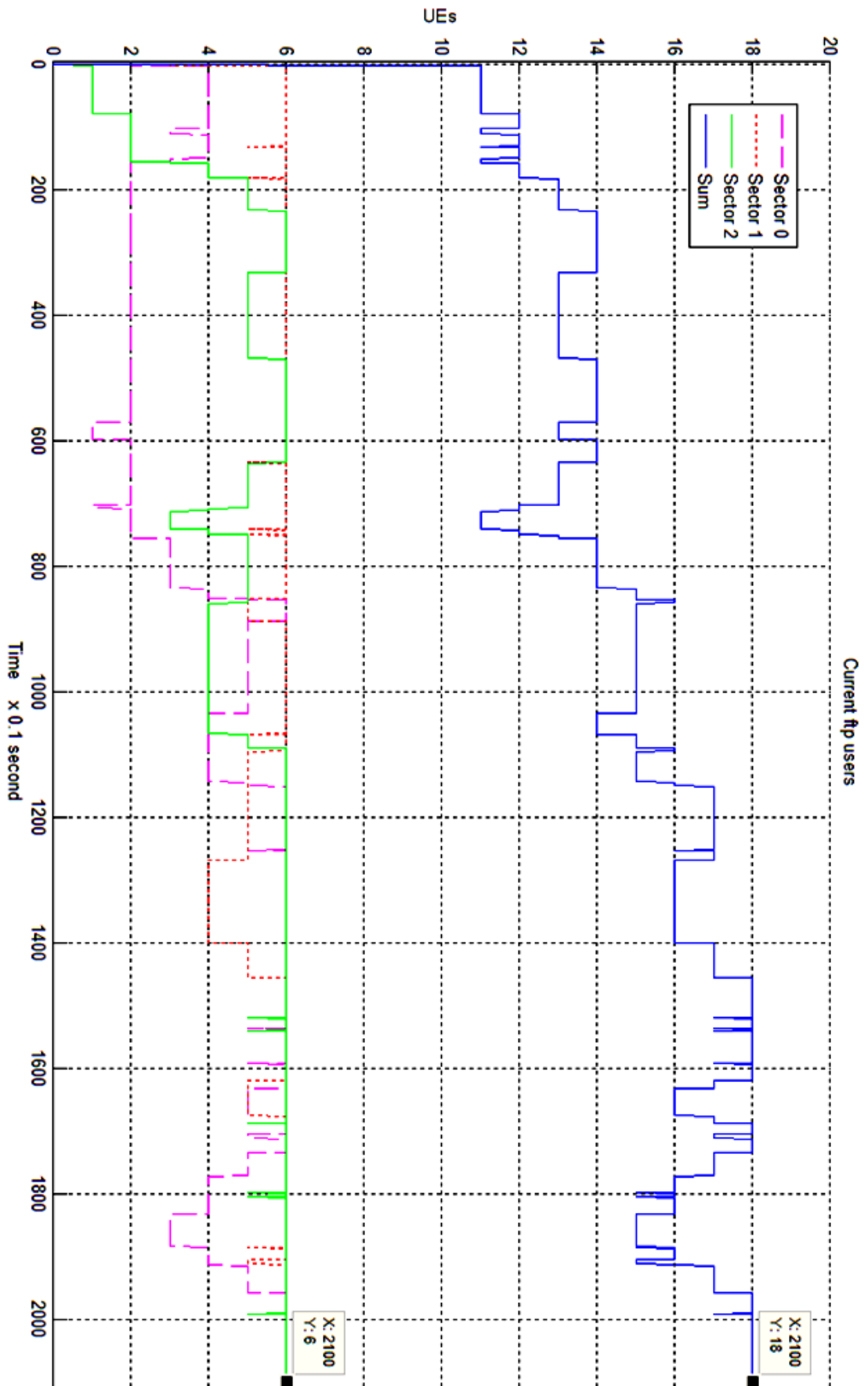

Figure C.58 Current FTP users for sectors

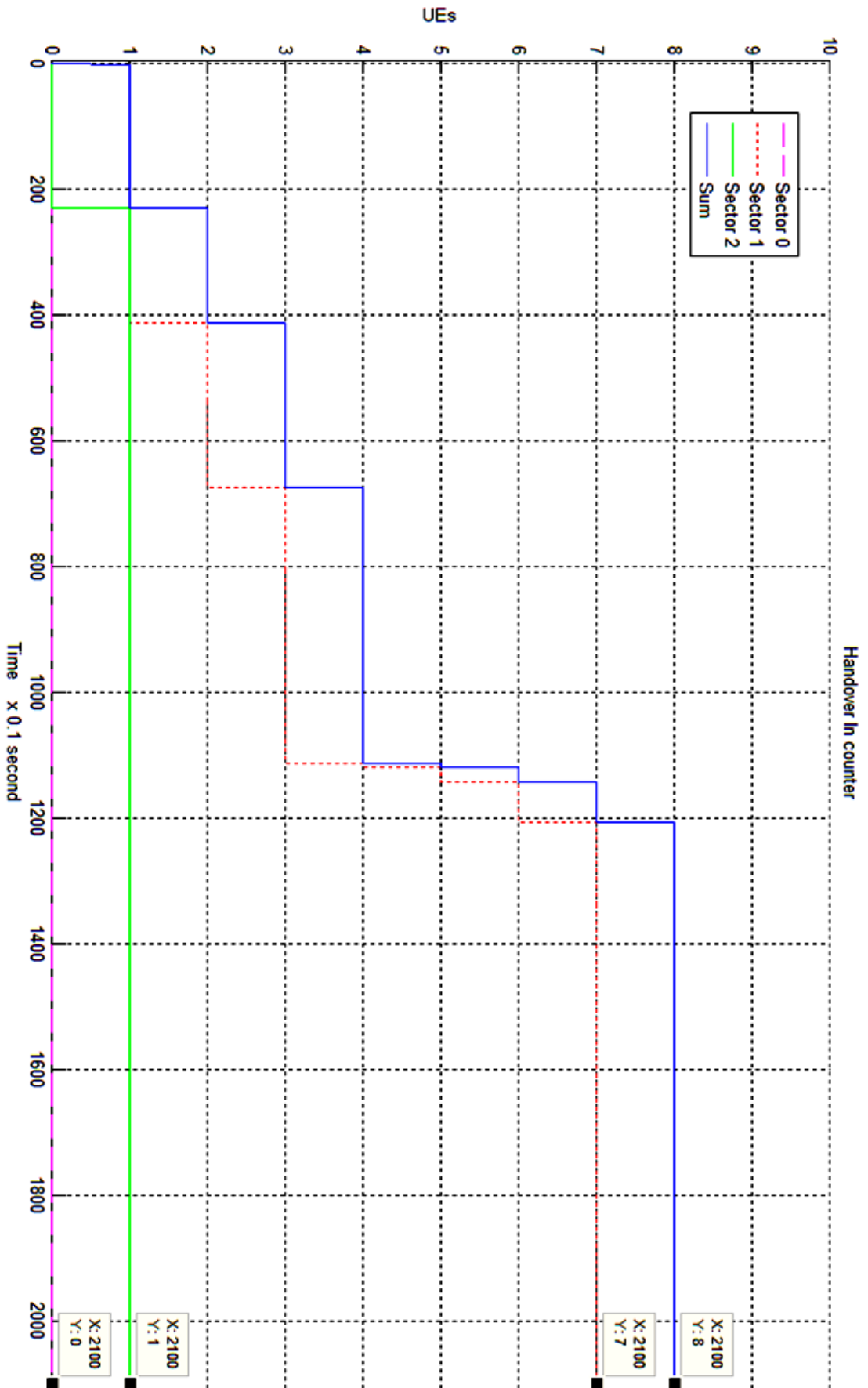

Figure C.59 Handover In counter for sectors

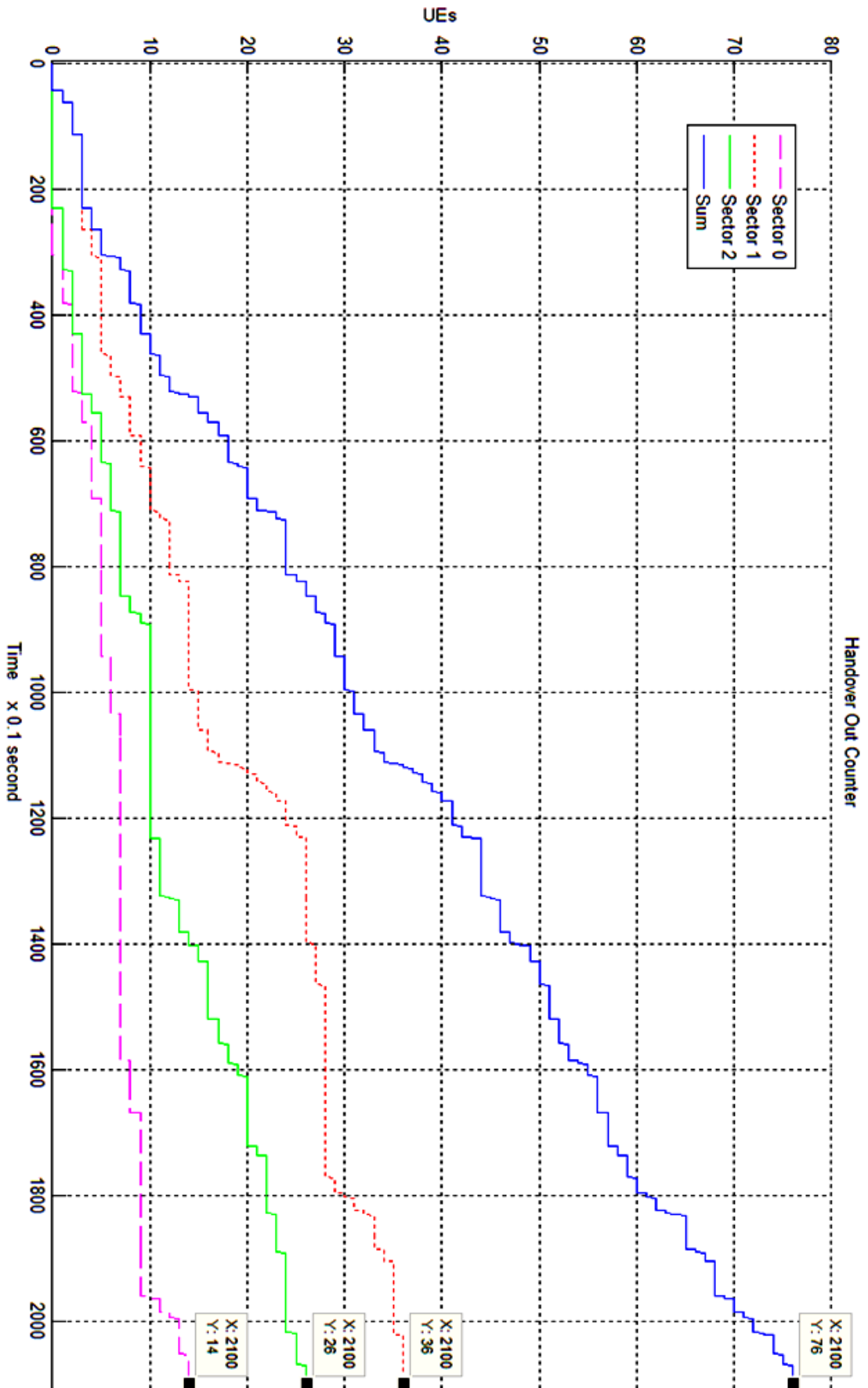

Figure C.60 Handover Out counter for sectors

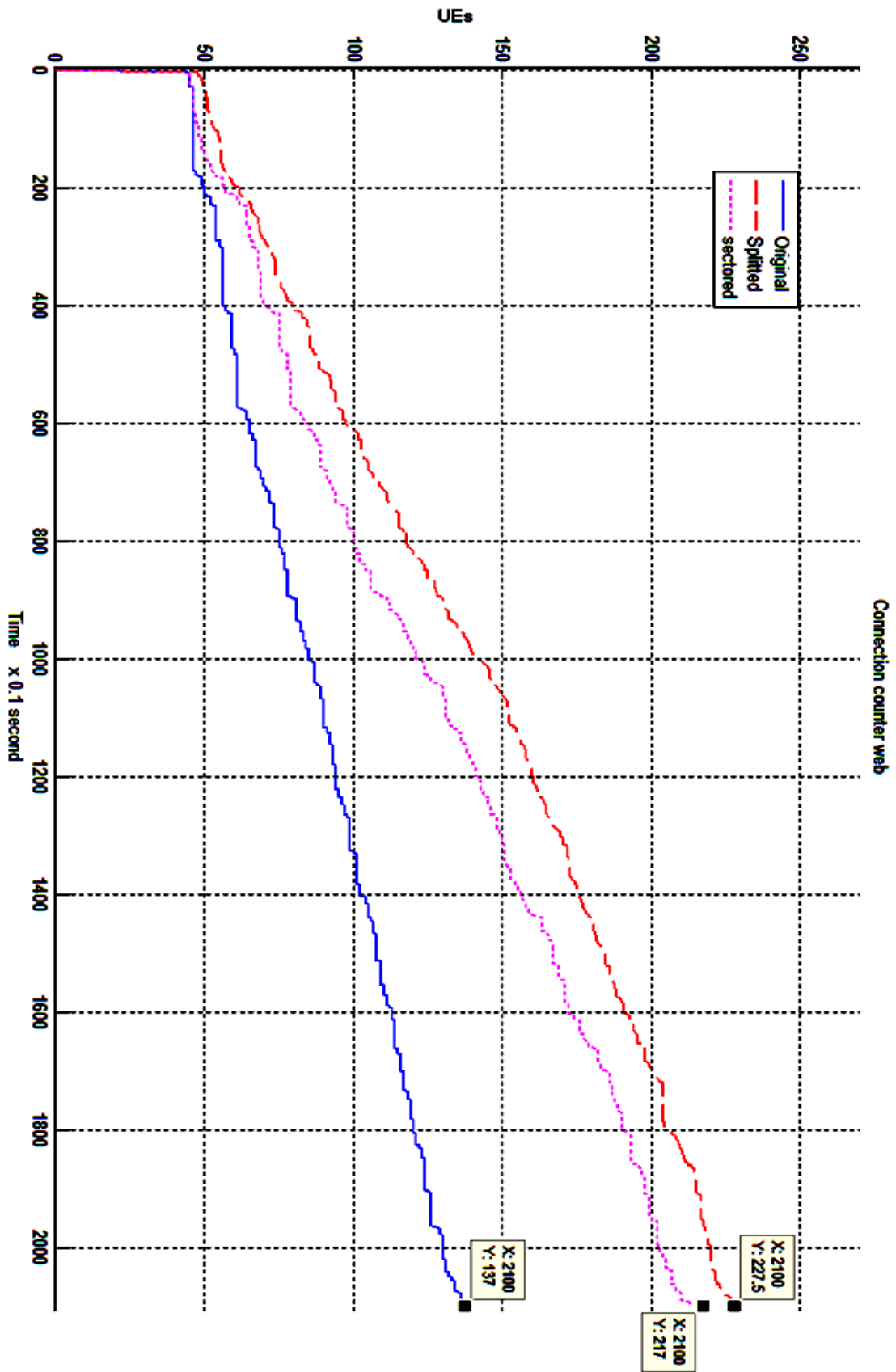

Figure C.61 Web connection counter comparisons between the two techniques

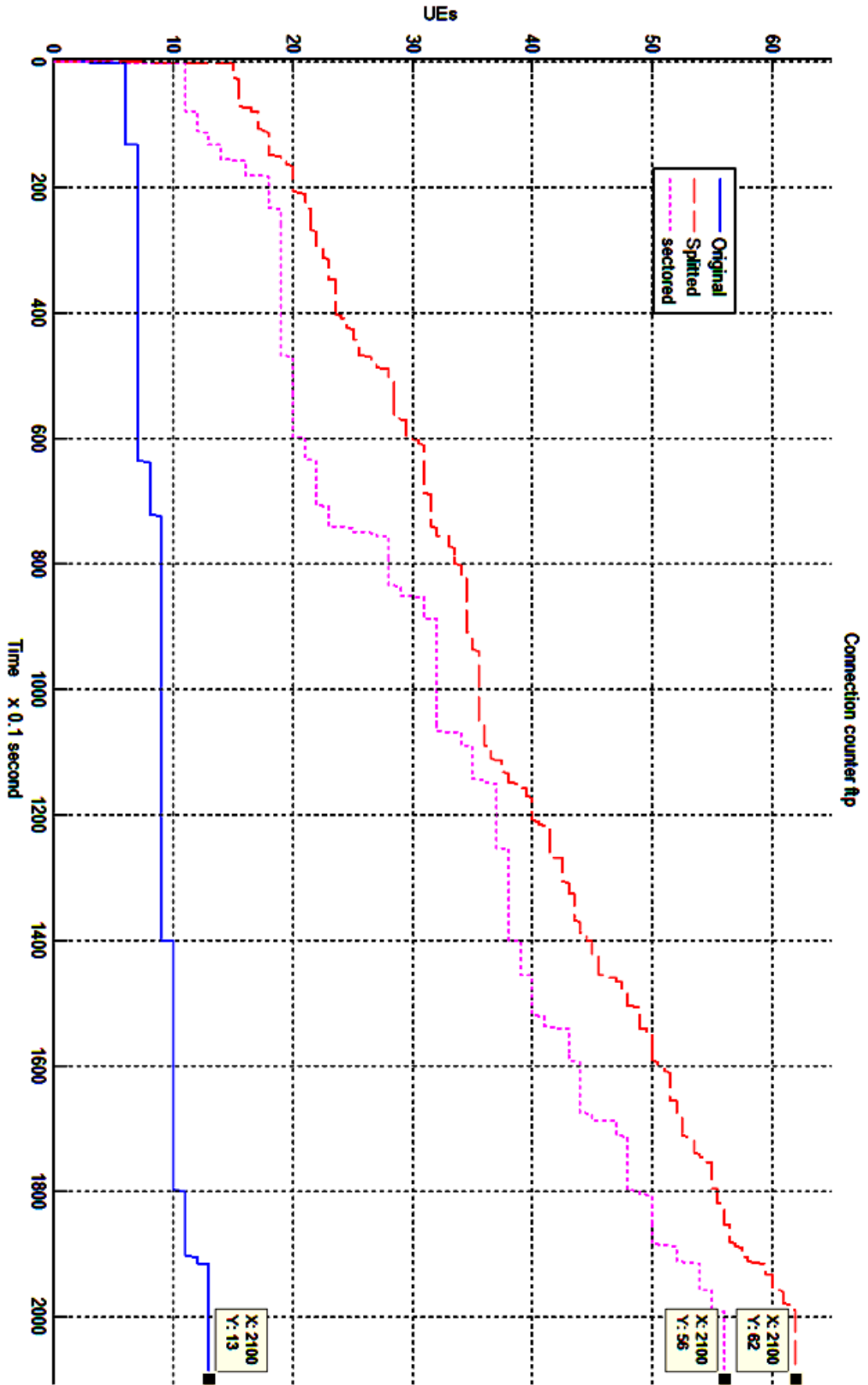

Figure C.62 FTP connection counter comparisons between the two techniques

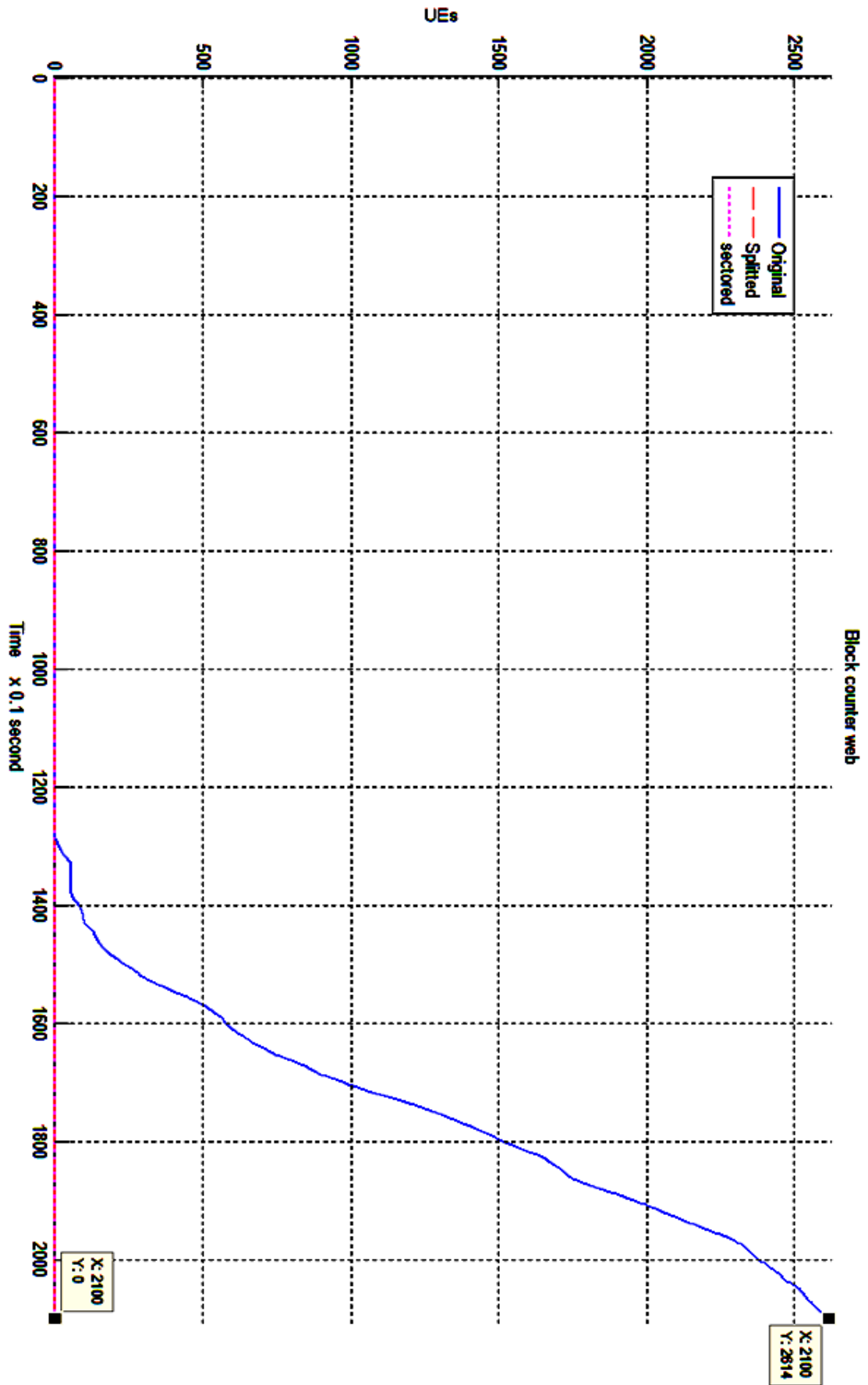

Figure C.63 Web block counter comparisons between the two techniques

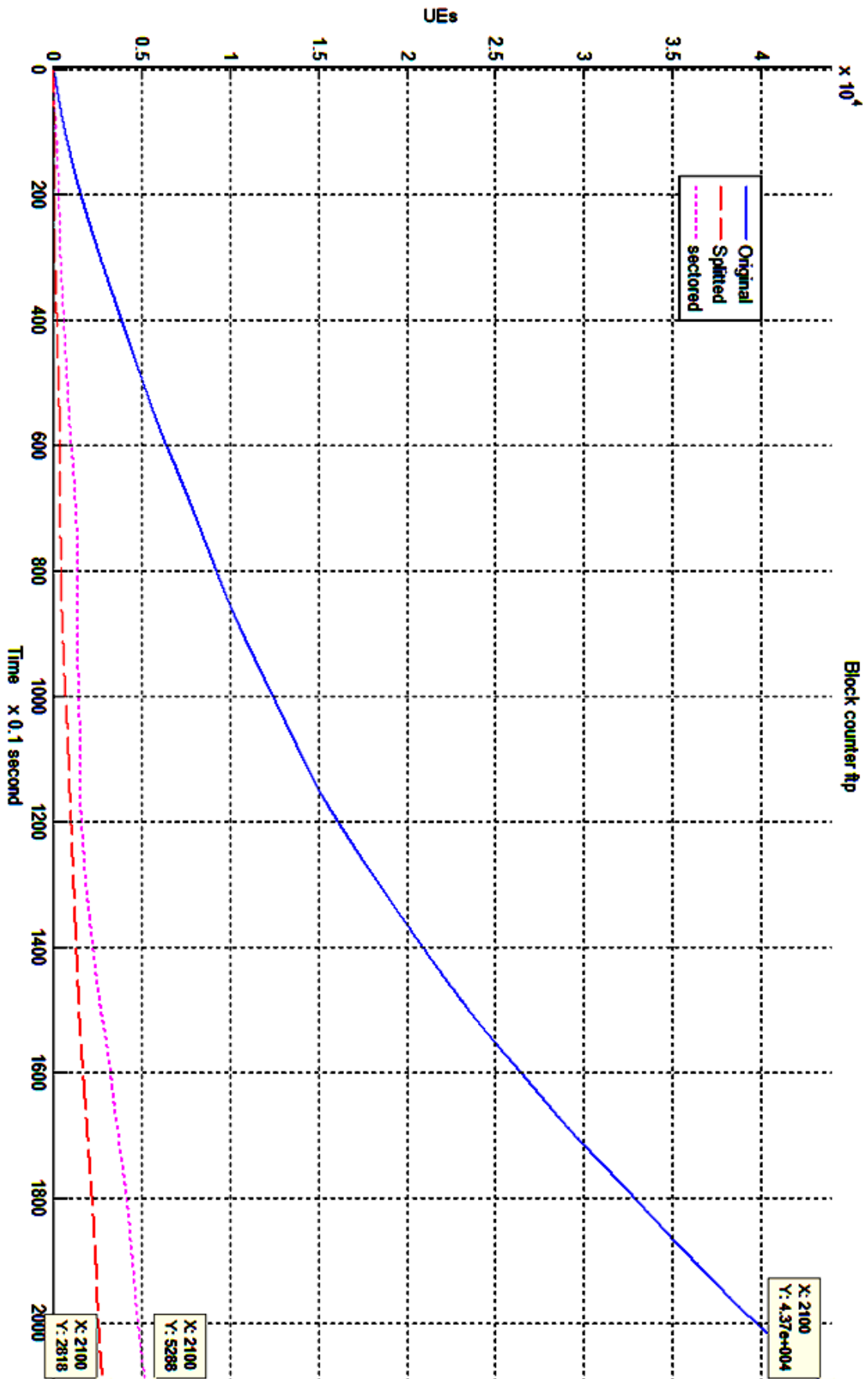

Figure C.64 FTP block counter comparisons between the two techniques

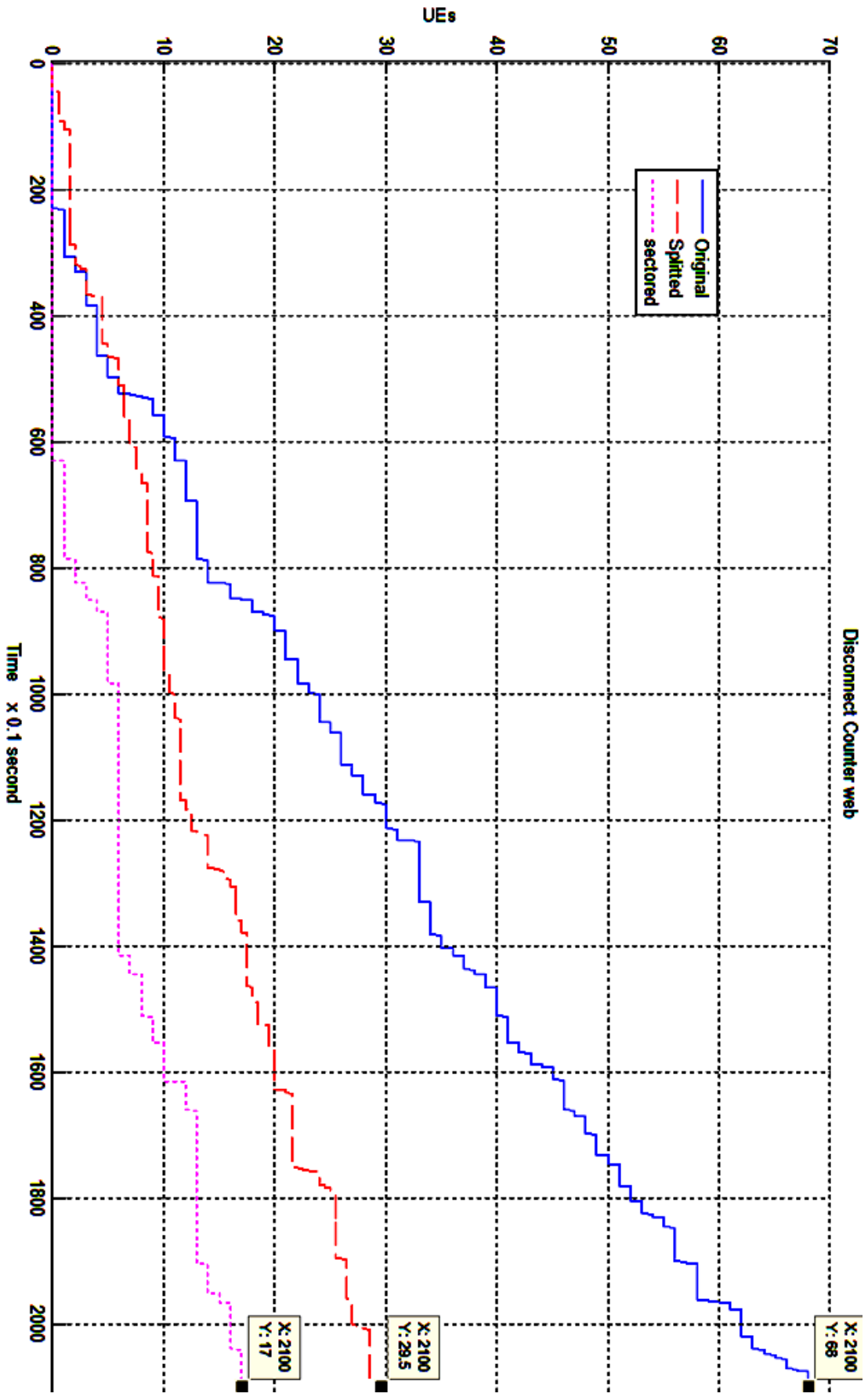

Figure C.65 Web disconnect counter comparisons between the two techniques

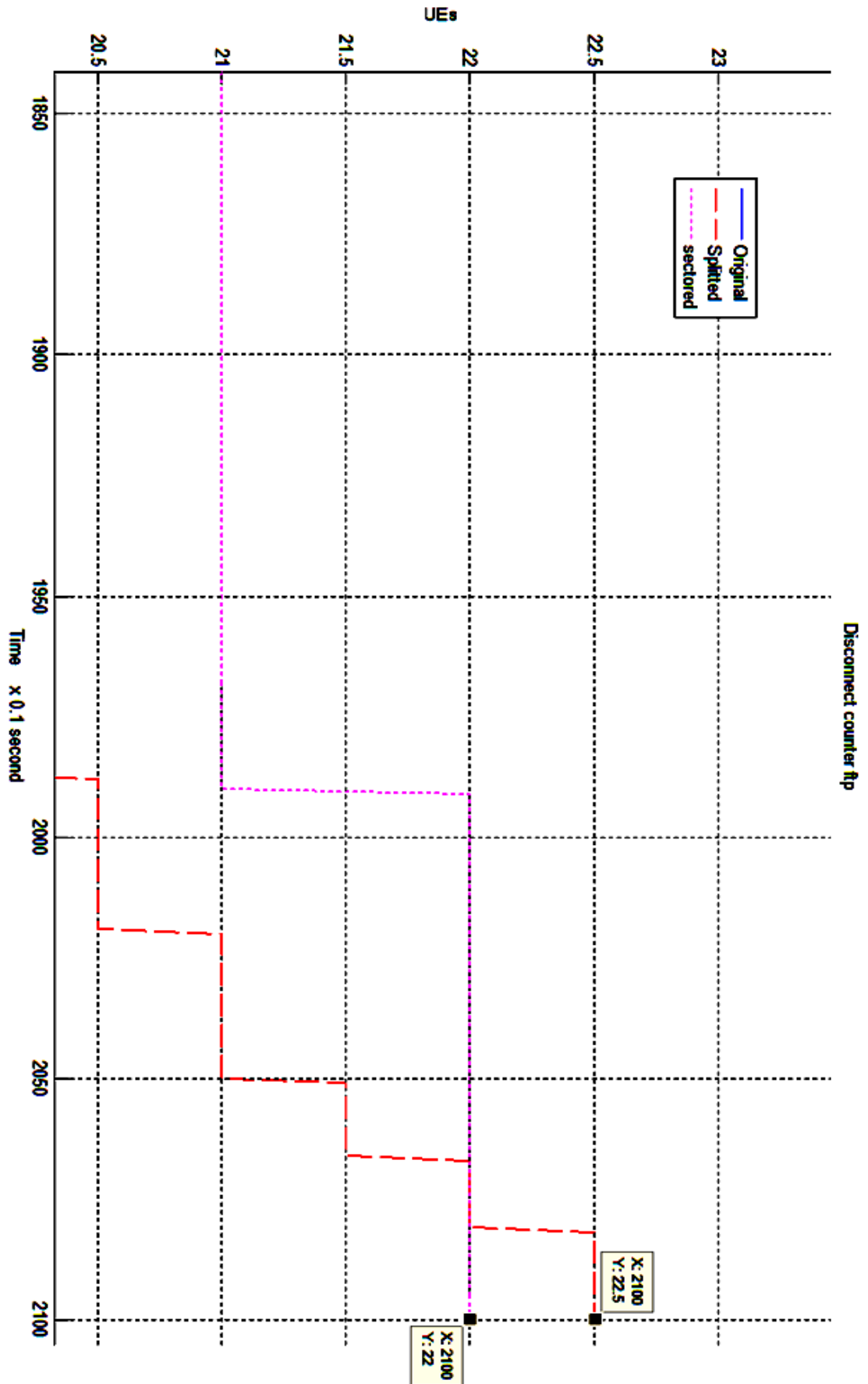

Figure C.66 Zoomed FTP disconnect counter comparisons between the two techniques

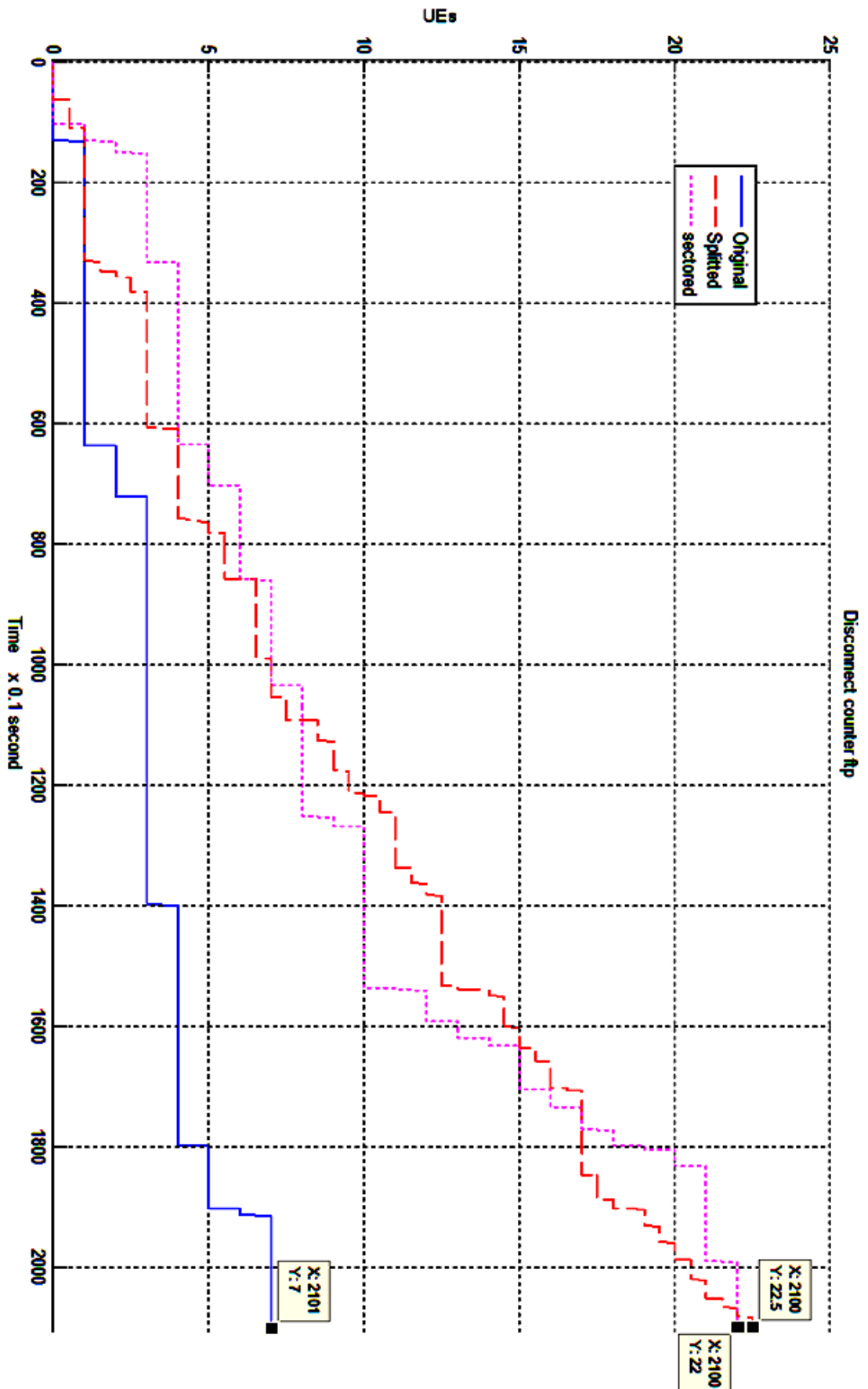

Figure C.67 FTP disconnect counter comparisons between the two techniques

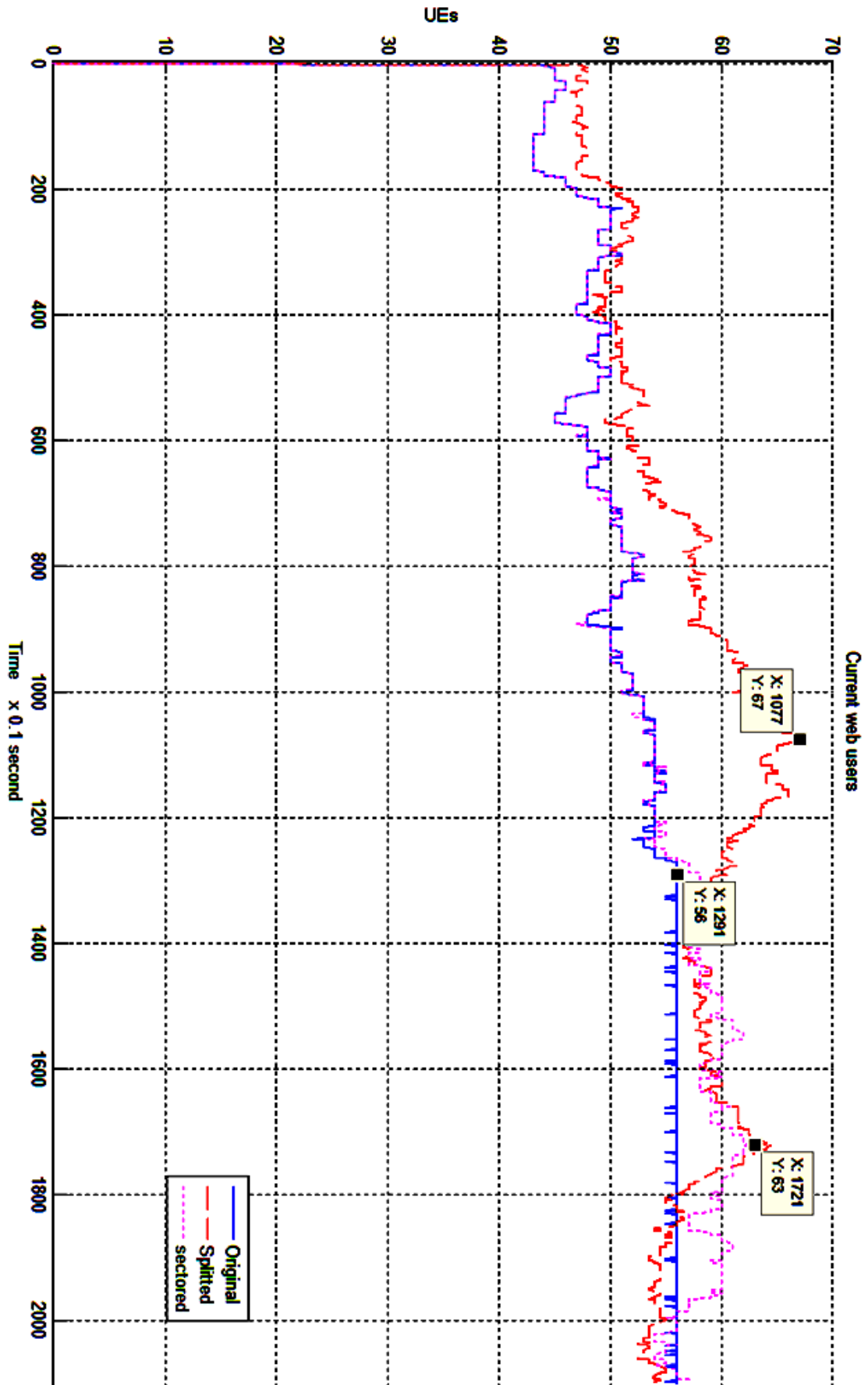

Figure C.68 Current web connections comparisons between the two techniques

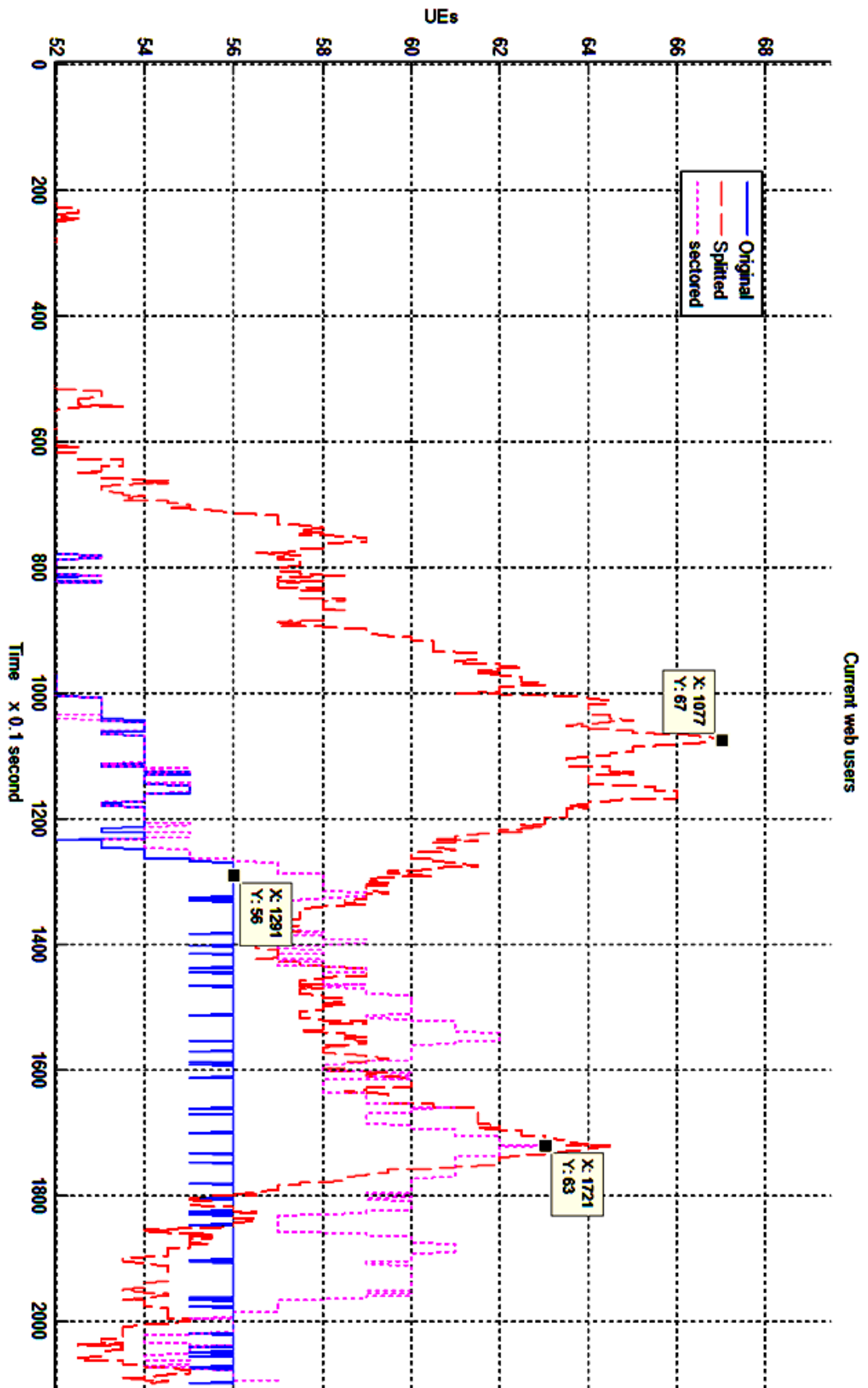

Figure C.69 Zoomed Current web connections comparisons between the two techniques

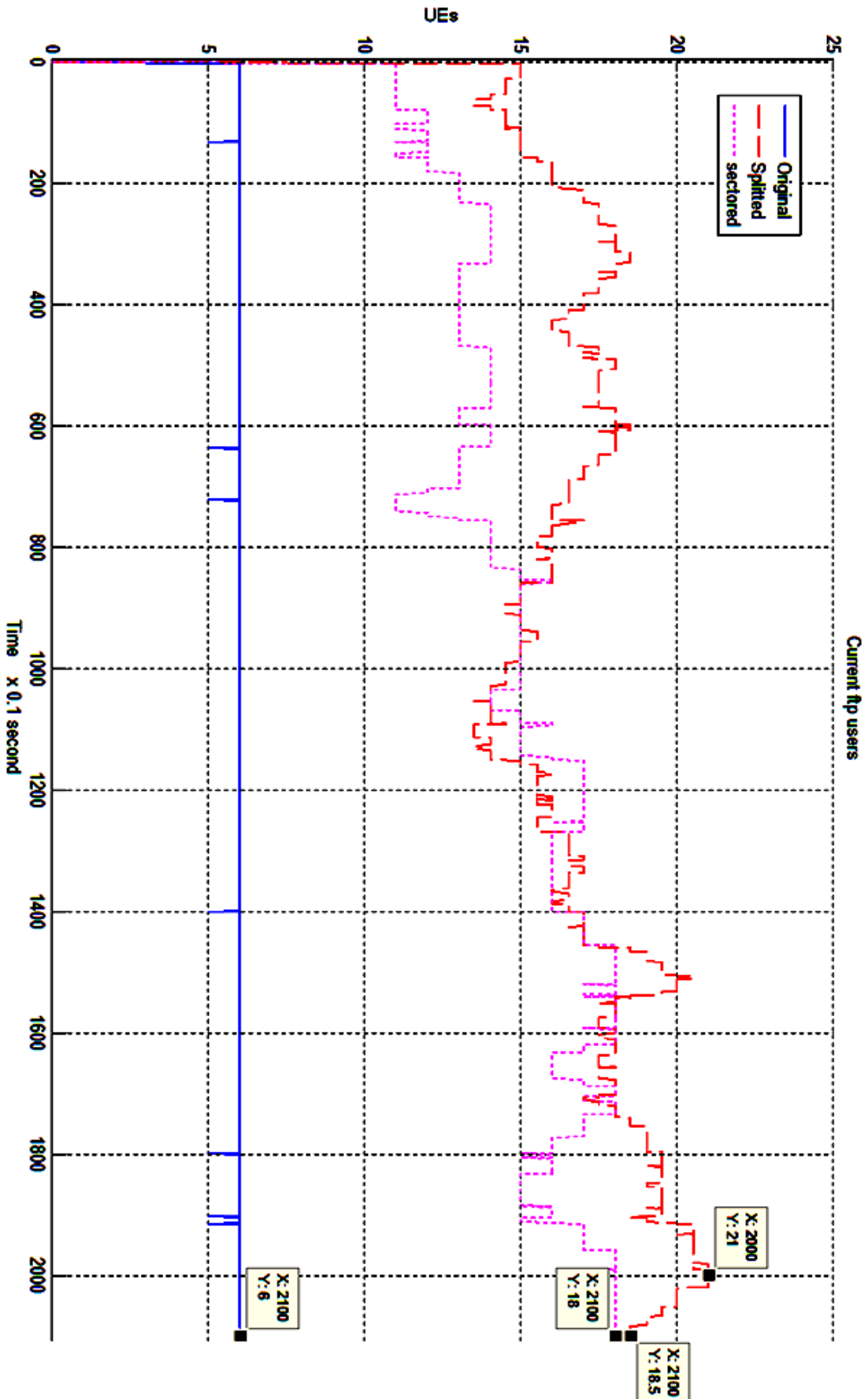

Figure C.70 Current FTP connections comparison between the two techniques

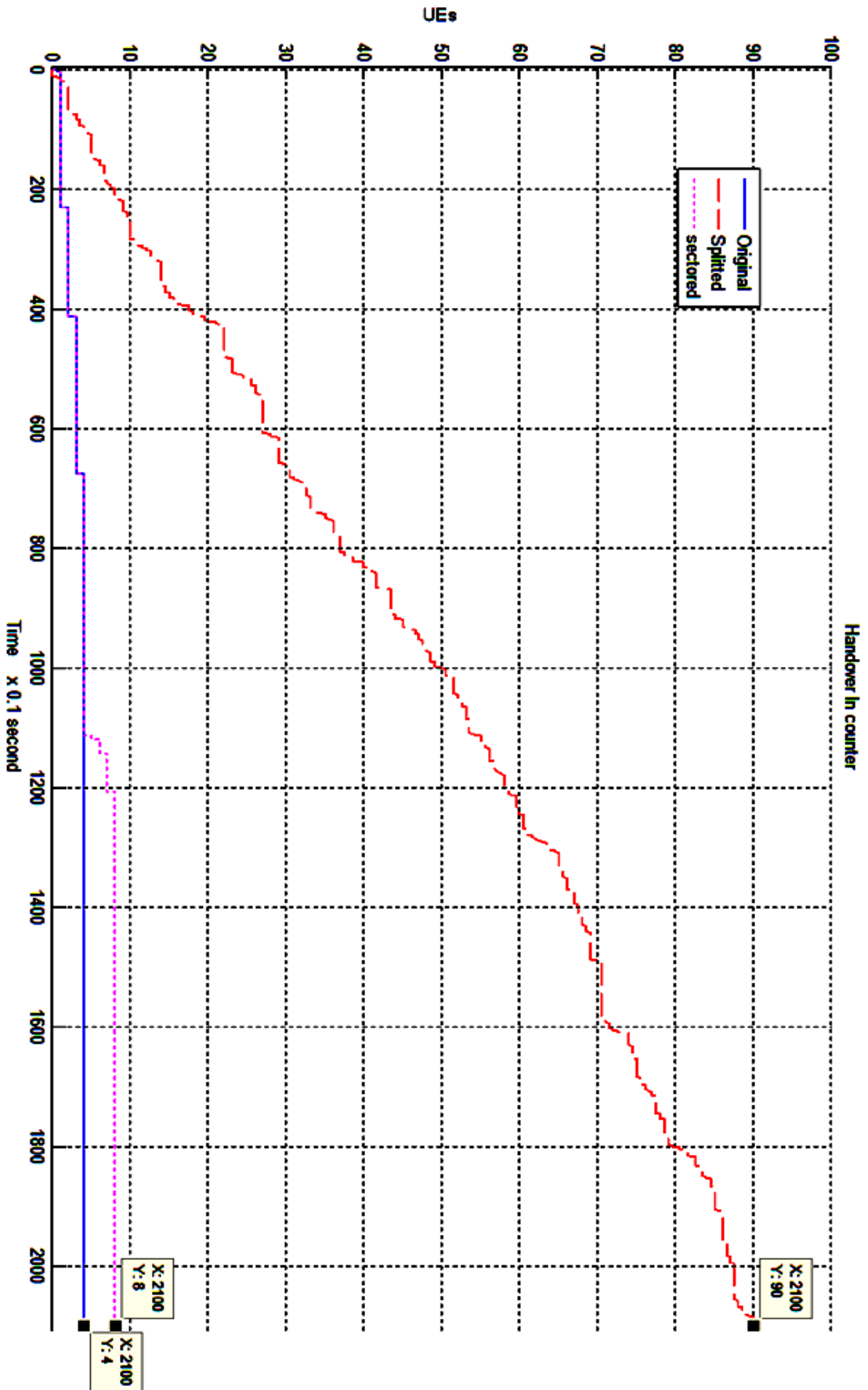

Figure C.71 Handover In comparisons between the two techniques

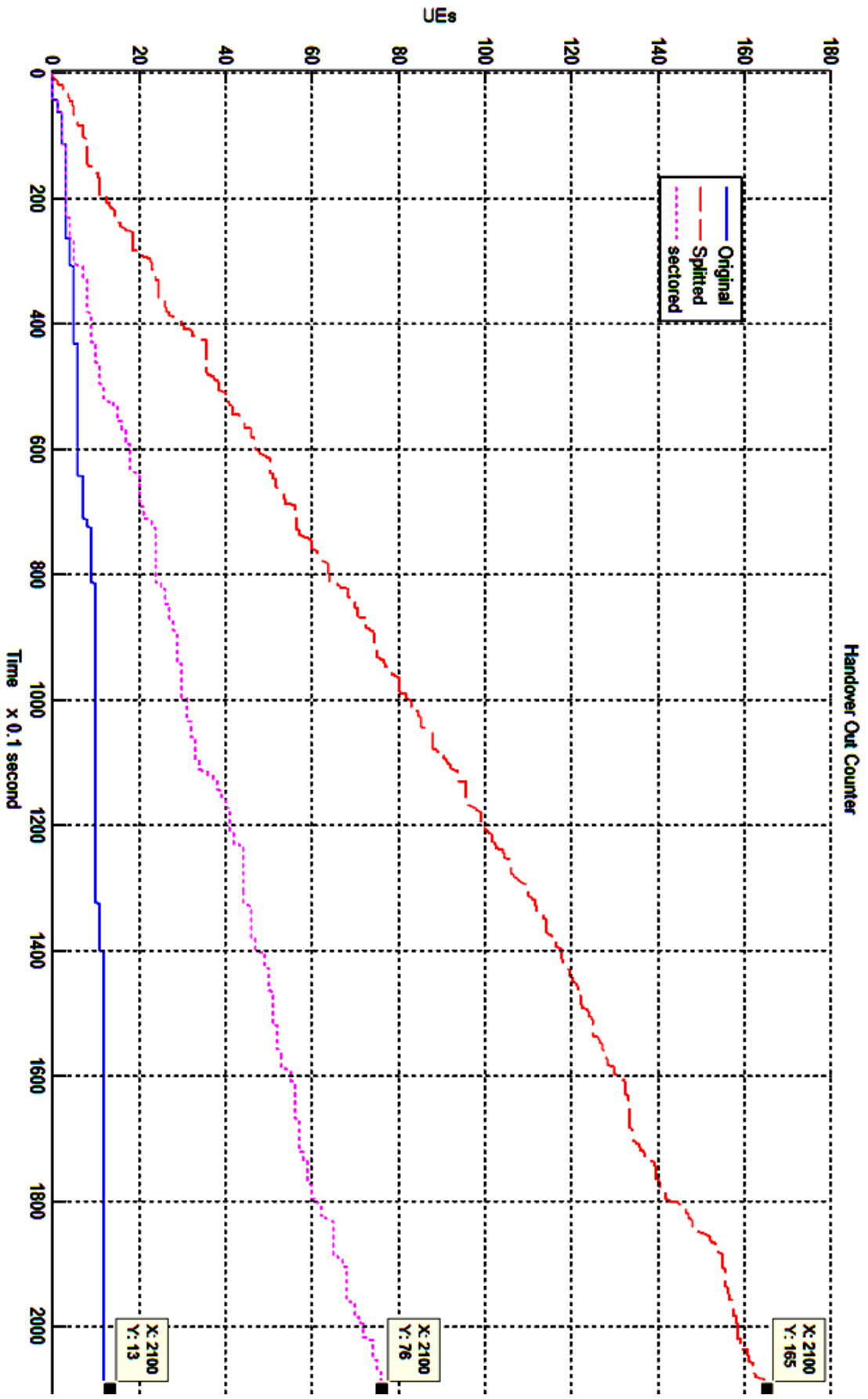

Figure C.72 Handover Out comparisons between the two techniques